



REPLACEMENT PARTS CATALOG

Publication No 00-5754

FOR 1975

TRIDENT MODEL T160

Commencing at engine/frame No. 00101

IMPORTANT

PLEASE CONTACT YOUR RETAIL TRIUMPH DEALER
TO OBTAIN REPLACEMENT PARTS.

NORTON TRIUMPH INTERNATIONAL LIMITED
KITTS GREEN - BIRMINGHAM B33. 0LF. - ENGLAND.

TELEPHONE. BIRMINGHAM 021-783-3657. - TELEX 339478.

Norton Triumph International Ltd. reserve the right to alter the designs or constructional details of their manufactures at any time without giving notice.

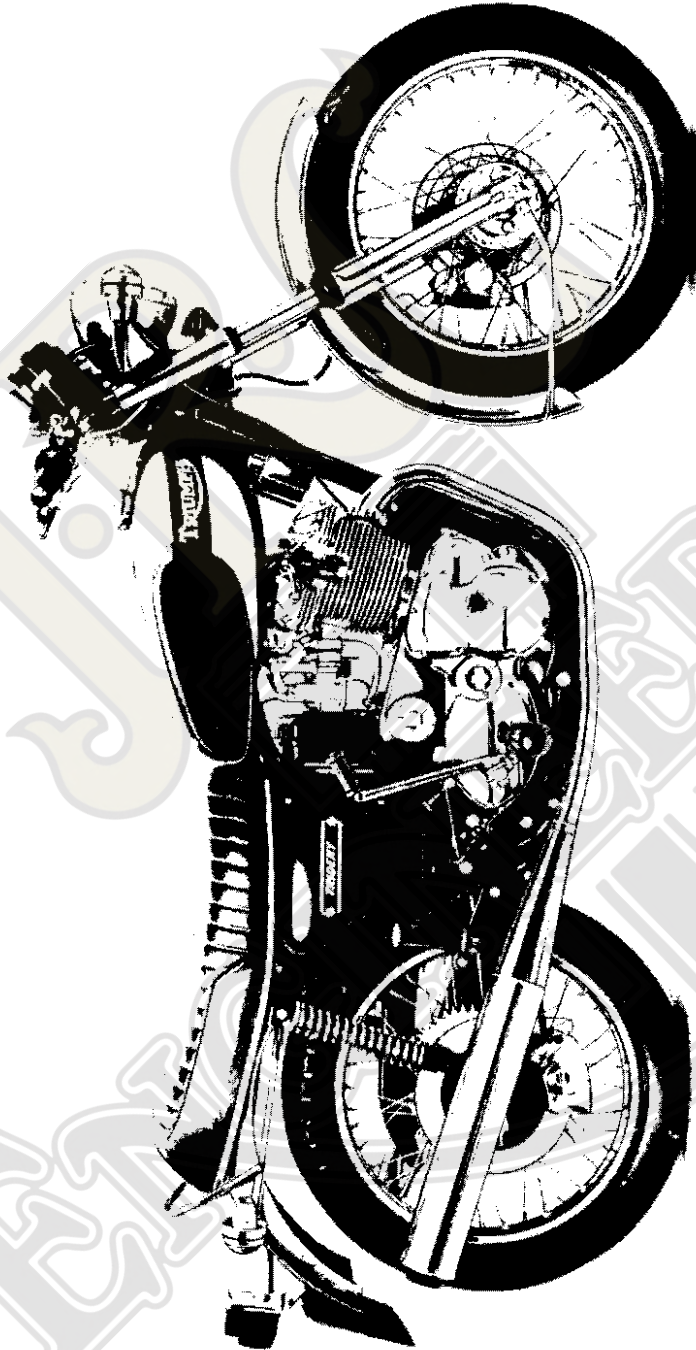

THE TRIUMPH TRIDENT. MODEL T160.

INTRODUCTION

The information contained in this catalog was complete and correct at the time of printing. Distributors will be informed of any subsequent alterations.

WARRANTY

Please refer to your local dealer or distributor for the latest terms of warranty.

Western U.S.A. Distributor:

Norton Triumph Corporation,
P.O. Box 275,
2765 East Huntington Drive,
Duarte,
California 91010.

Telex—Triumph Duar 67-5469
Telephone—213-359-3221
213-681-0255

Eastern U.S.A. Distributor:

Norton Triumph Corporation,
P.O. Box 400,
Timonium,
Maryland 21093,

Telex—Timo. Balt. 87-728
Telephone—301-252-1700

ENGINE AND FRAME NUMBERS

The engine number is located on the left side of the engine, immediately below the cylinder block/crank-case flange.

The frame number is located on the left side of the frame headlug, forward of the gasoline tank.

The engine and frame number should be quoted in full in any correspondence relating to the machine.

© COPYRIGHT 1974

Norton Triumph International Ltd.

All rights reserved. No part of this publication may be reproduced without permission.

TECHNICAL DATA

Bore and stroke	67 × 70 mm. (2.67 × 2.751 ins.)
Capacity	741 cm ³ (45 cu. ins.)
Compression ratio	9.5 : 1
Spark plugs	Champion N3
Carburetors	3 Amal Concentric 626
				Main jet	150
				Needle jet106
				Throttle valve	No. 4
Spark timing	38° B.T.D.C.
Valve clearances	Intake006 in. (0.15 mm); Exhaust .008 in. (0.20 mm)
Contact breaker gap014/.016 in. (0.35/0.40 mm)
Chains	Front	7/16" Duplex. × 70 links
				Rear	3/8" × 3/8" × 110 links
Capacities	Fuel Tank (Alternatives)	4½ gallons; 2½ gallons.
				Oil Tank	6 U.S. pints; (5 Brit. pints); (2.8 liters) working capacity.
				Transmission (Gearbox)	1½ U.S. pints; (1½ Brit. pints); (850 cm ³).
				Primary Chaincase (Self-levelling)	½ U.S. pint; (½ Brit. pints); (350 cm ³).
				Front Forks (each leg)	210 cm ³ .
Tire size	Front	4-10—19 ins.
				Rear	4-10—19 ins.
Brake size	Front and Rear	10 in. dia. disc.
Sprockets	Transmission (Gearbox)	19 T
				Rear Wheel	50 T
Gear Ratios	High	4.92
				4th	5.85
				3rd	6.89
				2nd	9.04
				Low	12.71
Dimensions	Wheelbase	58 ins. (147.5 cm)
				Ground clearance at crankcase	7 ins. (17.8 cm)
				Overall length	88 ins. (223.5 cm)
				Seat Height (unladen)	31½ ins. (79.4 cm)

USING THE REPLACEMENT PARTS LIST

LOCATING AND ORDERING THE PARTS

An index is provided on page 13 to enable the parts or group of parts to be located.

Select the required component from the illustrations, note its reference number, and from the corresponding column on the opposite page, obtain the part number and correct name of the item.

If proprietary parts are listed under manufacturers part numbers only, they are not available from Norton Triumph International Ltd, but must be obtained direct from the manufacturers. (U.S.A. excepted)

Proprietary components should be ordered through the main distributors, whose addresses are given on page 3. (U.S.A. only).

When ordering, quote the part number and the description of the item required. In most cases the illustrations show the assembly order, which should assist in identifying the parts. Order items in single units, not "pairs", etc.

Throughout this catalog the components included in an assembled unit are indented and listed directly below in the description column, reverting to the original alignment when the assembly is completed. To order the assembled unit quote the assembly number only. The component parts may be obtained separately if desired.

ENGINE AND FRAME NUMBERS MUST BE QUOTED IN FULL WHEN ORDERING SPARE PARTS AND IN ANY CORRESPONDENCE RELATING TO THE MOTOR-CYCLE.

OBTAINING PARTS

Spare parts can be obtained from an authorised Triumph/Norton dealer only, and we advise owners to order parts through their nearest dealer. If the item is one which may have to be obtained specially, an additional charge for postage and carriage will be incurred.

SPARE PARTS ARE NOT SUPPLIED DIRECTLY TO PRIVATE OWNERS FROM THE FACTORY.

If the part number is quoted when ordering, it is unnecessary to send a pattern of the item. If however, it is necessary to send a pattern, this should bear the sender's name and address together with clear instructions. A copy of the advice should be sent under separate cover, together with a remittance and all parts forwarded carriage paid.

NORTON TRIUMPH CORPORATION AND NORTON TRIUMPH INTERNATIONAL LIMITED, WARN AGAINST THE PURCHASE OF PARTS WHICH ARE NOT MANUFACTURED OR APPROVED BY THEM, BECAUSE THIS WILL INVALIDATE THE WARRANTY.

COLORS

Gas tank	Yellow/White or Burgundy/White.
Fenders	Chromium Plated.
Side Cover and Oil Tank	Black.

SCREW THREADS

Details of thread forms and sizes are quoted after the description of Nuts, Bolts, Screws and Studs.

Example: 14-0102, Bolt ($\frac{1}{4}$ " U.N.F. \times $\frac{3}{8}$ " U.H.) = $\frac{1}{4}$ " diameter Unified Fine Thread \times $\frac{3}{8}$ " long, from underside of head to end of bolt.

ABBREVIATIONS:

B.A.	= British Association.	U.H.	= Length measured from the underside of bolt head.
UN.C.	= Unified Coarse.	C/W	= Complete with.
A/F	= Across Flats of hexagon.	D.S.	= Driving Side (Engine).
UN.F	= Unified Fine.	T.S.	= Timing Side (Engine).
UN.S.	= Unified Special.		

SERVICE TOOLS

A complete range of Service Tools is contained in the Service Tools Catalog. They may be obtained through a Norton/Triumph dealer but, because they are costly and are rarely required, it may be advisable to have the work for which they are required, carried out by the dealer.

MATERIALS

Highly-stressed components which are manufactured from special materials are pinpointed by an asterisk (or other indication) and the British Standard symbol for the material is quoted at the foot of the page.

WASHERS

Dimensions of washers are quoted in the following sequence:- Inside diameter, outside diameter, thickness. Normally, washers are of steel, but where fiber, aluminium, or other non-ferrous materials are used, these are specified by name.

SERVICE MANUAL

For owners with sufficient knowledge and facilities for carrying out major overhauls, a Service Manual is available for the Trident. The Manual contains much useful information, in addition to providing detailed instructions on dismantling and rebuilding of all the major assemblies. It is obtainable from Norton/Triumph dealers.

MAJOR ASSEMBLED UNITS

Spares No.	Description
71-3652	ENGINE GEARBOX UNIT less carburetors and exhaust system.
71-1351	OIL PUMP, C/W DRIVING GEAR.
57-4675	CLUTCH ASSEMBLY.
57-4895	PRIMARY DRIVE SHOCK ABSORBER ASSEMBLY.
71-3641	CRANKCASE COMPLETE (left, centre and right).
83-5811	FRAME.
83-5368	SWINGING ARM WITH BUSHES.
97-4605	FRONT FORK ASSEMBLY.
97-5047	FRONT FORK ASSEMBLY. (EUROPEAN CONTINENT ONLY).
37-4305	FRONT HUB WITH SPOKES AND RIM.
37-4141	FRONT WHEEL ASSEMBLY.
37-4254	REAR HUB WITH SPOKES AND RIM.
37-4252	REAR WHEEL ASSEMBLY.
60-4102	FRONT BRAKE MASTER CYLINDER ASSEMBLY.
60-4401	REAR-BRAKE MASTER CYLINDER ASSEMBLY.

KITS OF PARTS

BRAKES.

Master cylinder repair kit	99-2768 (front), 19-4700 (rear).
Brake pad kit	99-2769 (front and rear)

LOCTITE

10 bottle trade pack	00-7009
----------------------	---------

GASKET SETS

Top decarbonisation (i.e. cylinder head etc).	00-3177
Full decarbonisation	00-3322

OVERSIZE AND UNDERSIZE COMPONENTS

PISTONS (Complete with rings, wrist pins and circlips)

Compression ratio 9.5 : 1

}	70-9762	+ .010 in. oversize.
	70-9763	+ .020 in. oversize.
	70-9764	+ .040 in. oversize.

PISTON RINGS

99-3781	{ 2 off 70-9016 Compression ring 1 off 70-9766 Scraper ring }	+ .010 in. oversize.
99-3782	{ 2 off 70-9017 Compression ring 1 off 70-9767 Scraper ring }	+ .020 in. oversize.
99-3783	{ 2 off 70-9018 Compression ring 1 off 70-9768 Scraper ring }	+ .040 in. oversize.

BIG-END BEARING SHELLS

70-9023	— .010 in. undersize.
70-9024	— .020 in. undersize.
70-9025	— .030 in. undersize.
70-9026	— .040 in. undersize.

MAIN BEARING SHELLS

70-9027	— .010 in. undersize.
70-9028	— .020 in. undersize.
70-9029	— .030 in. undersize.
70-9030	— .040 in. undersize.

CYLINDER BLOCK

71-4404	+ .010 in. oversize.
71-4405	+ .020 in. oversize.
71-4406	+ .040 in. oversize.

VALVE GUIDES

71-3280	+ .002 in. oversize.
71-3281	+ .015 in. oversize.

**NAMES AND ADDRESSES OF PROPRIETARY MANUFACTURERS
(NOT APPLICABLE IN U.S.A.)**

The Norton/Triumph warranty does not apply to proprietary components and any repairs or claims regarding these products should be referred direct to the manufacturers concerned. Their names and addresses are as follows:-

ACCESSORIES

Doherty Motor Cycle Accessories Ltd.,
Aston Brook Street,
Birmingham 6.

CARBURETORS,

Amal Limited,
Holdford Road,
Witton,
Birmingham 6.

ELECTRICAL EQUIPMENT.

Joseph Lucas (Sales and Service) Limited,
Great Hampton Street,
Birmingham. 18.

SPARK PLUGS

Champion Sparking Plug Co Limited,
Feltham,
Middlesex

TIRES

Dunlop Co Limited,
Fort Dunlop,
Birmingham 24.

BRAKES, CLUTCH

Automotive Products Co. Ltd.
P.O. Box 14, Southam Road,
Banbury,
Oxfordshire.

CHAINS

Renold Limited,
Wythenshawe,
Manchester.

SUSPENSION UNITS

Girling Limited,
Birmingham Road,
West Bromwich,
Staffordshire.

INSTRUMENTS.

Smith's Industries Limited,
Motor Accessory Division,
50 Oxgate Lane,
Cricklewood,
London, N.W.2.

SERVICING OF PROPRIETARY MANUFACTURERS COMPONENTS (U.S.A.)

East.

Norton Triumph Corporation
P.O. Box 400,
2034 Green Spring Road,
Timonium,
Maryland 21093.

West.

Norton Triumph Corporation
P.O. Box 275,
2765 E. Huntingdon Drive,
Duarte,
California 91010.

STEERING LOCK AND KEY NUMBERS

Lock No.	Key No.	Lock No.	Key No.	Lock No.	Key No.
EJR 1	19-5151	EJR 18	19-5168	EJR 35	19-5185
EJR 2	19-5152	EJR 19	19-5169	EJR 36	19-5186
EJR 3	19-5153	EJR 20	19-5170	EJR 37	19-5187
EJR 4	19-5154	EJR 21	19-5171	EJR 38	19-5188
EJR 5	19-5155	EJR 22	19-5172	EJR 39	19-5189
EJR 6	19-5156	EJR 23	19-5173	EJR 40	19-5190
EJR 7	19-5157	EJR 24	19-5174	EJR 41	19-5191
EJR 8	19-5158	EJR 25	19-5175	EJR 42	19-5192
EJR 9	19-5159	EJR 26	19-5176	EJR 43	19-5193
EJR 10	19-5160	EJR 27	19-5177	EJR 44	19-5194
EJR 11	19-5161	EJR 28	19-5178	EJR 45	19-5195
EJR 12	19-5162	EJR 29	19-5179	EJR 46	19-5196
EJR 13	19-5163	EJR 30	19-5180	EJR 47	19-5197
EJR 14	19-5164	EJR 31	19-5181	EJR 48	19-5198
EJR 15	19-5165	EJR 32	19-5182	EJR 49	19-5199
EJR 16	19-5166	EJR 33	19-5183	EJR 50	19-5200
EJR 17	19-5167	EJR 34	19-5184		

Note: Certain European countries require the installation of special steering locks (Neiman), and hence the above information does not apply to models supplied to those countries

IGNITION LOCK AND KEY NUMBERS

Lock No.	Key No.	Lock No.	Key No.	Lock No.	Key No.
FS 876	19-5614	FS 903	19-5641	FS 930	19-5668
FS 877	19-5615	FS 904	19-5642	FS 931	19-5669
FS 878	19-5616	FS 905	19-5643	FS 932	19-5670
FS 879	19-5617	FS 906	19-5644	FS 933	19-5671
FS 880	19-5618	FS 907	19-5645	FS 934	19-5672
FS 881	19-5619	FS 908	19-5646	FS 935	19-5673
FS 882	19-5620	FS 909	19-5647	FS 936	19-5674
FS 883	19-5621	FS 910	19-5648	FS 937	19-5675
FS 884	19-5622	FS 911	19-5649	FS 938	19-5676
FS 885	19-5623	FS 912	19-5650	FS 939	19-5677
FS 886	19-5624	FS 913	19-5651	FS 940	19-5678
FS 887	19-5625	FS 914	19-5652	FS 941	19-5679
FS 888	19-5626	FS 915	19-5653	FS 942	19-5680
FS 889	19-5627	FS 916	19-5654	FS 943	19-5681
FS 890	19-5628	FS 917	19-5655	FS 944	19-5682
FS 891	19-5629	FS 918	19-5656	FS 945	19-5683
FS 892	19-5630	FS 919	19-5657	FS 946	19-5684
FS 893	19-5631	FS 920	19-5658	FS 947	19-5685
FS 894	19-5632	FS 921	19-5659	FS 948	19-5686
FS 895	19-5633	FS 922	19-5660	FS 949	19-5687
FS 896	19-5634	FS 923	19-5661	FS 950	19-5688
FS 897	19-5635	FS 924	19-5662	FS 951	19-5689
FS 898	19-5636	FS 925	19-5663	FS 952	19-5690
FS 899	19-5637	FS 926	19-5664	FS 953	19-5691
FS 900	19-5638	FS 927	19-5665	FS 954	19-5692
FS 901	19-5639	FS 928	19-5666	FS 955	19-5693
FS 902	19-5640	FS 929	19-5667		

ILLUSTRATIONS INDEX

Figure 1	Crankshaft and Connecting Rods	14
Figure 2	Crankcase	16
Figure 3	Oil Pump and Crankcase Filters	18
Figure 4	Cylinder Head and Rocker Boxes	20
Figure 5	Carburetors	22
Figure 6	Cylinder Block, Push Rods, Tappets	24
Figure 7	Timing Cover and Contact Breaker	26
Figure 8	Carburetor Adaptor and Throttle linkage	28
Figure 9	Transmission (Gearbox) Outer Cover, gearshift linkage, and kickstarter pedal	30
Figure 10	Transmission (Gearbox) inner cover and gearshift mechanism	32
Figure 11	Transmission (Gearbox) Shafts and gearbox	34
Figure 12	Electric Starter Mechanism	36
Figure 13	Clutch and Clutch Operating Mechanism	38
Figure 14	Inner Primary Chaincase	40
Figure 15	Outer Primary Chaincase	42
Figure 16	Primary Shock Absorber and oil pump drive	44
Figure 17	Frame	46
Figure 18	Swinging Fork and Suspension Units	48
Figure 19	Engine Unit Fittings and Foot Pegs	50
Figure 20	Exhaust System and pillion footpegs	52
Figure 21	Front Forks	54
Figure 22	Front Wheel	56
Figure 23	Front Brake	58
Figure 24	Rear Wheel	60
Figure 25	Rear Brake	62
Figure 26	Oil Cooler	64
Figure 27	Gas Tank and pipes	66
Figure 28	Oil tank and pipe lines	68
Figure 29	Battery carrier and air filter	70
Figure 30	Side Panel and Twinseat	72
Figure 31	Fenders and Stays	74
Figure 32	Tail lite and rear indicator lite	76
Figure 33	Handlebar and Control levers	78
Figure 34	Control Cables	80
Figure 35	Toolkit	82
Figure 36	Speedometer, Tachometer and drive, switch panel	84
Figure 37	Electrical Equipment—Coils Rectifier, Battery, etc.	86
Figure 38	Electrical Equipment—Headlite and front indicator lite	88
Figure 39	Special items—Europe only	90

INDEX

	<i>Page</i>		<i>Page</i>
AIR FILTER	71	IGNITION SWITCH	89
ALTERNATOR	27	KICKSTARTER	31
AUTO-ADVANCE UNIT	27	MASTER CYLINDER	59, 63
BULBS	89	MUFFLERS	53
BATTERY CARRIER	71	NUMERICAL INDEX	92
BRAKE SWITCH	87	OIL COOLER	65
BRAKE UNIT	59, 63	OIL PUMP	19
BRAKE PEDAL	63	OIL TANK	69
BRAKE PADS	59, 63	OIL FILTER	69
BRAKE PIPES	59, 63	OVERSIZE PARTS	8
BRAKE MASTER CYLINDER	59, 63	PISTONS	14
CAMSHAFTS, INTAKE AND EXHAUST	15	PILLION FOOTPEGS	53
CARBURETORS	23	PROP STAND	47
CARBURETOR ADAPTOR	29	PUSH RODS	25
CENTER STAND	47	REAR BRAKE	63
CHAINS	45	REAR LITE	77
CHAINCASE	41, 43	REAR WHEEL	61
CLUTCH	39	RECTIFIER	87
COIL	87	REFLECTORS (front)	65
CONDENSER PACK	87	ROCKERS	21
CONNECTING RODS	15	ROCKER BOX	21
CONTACT BREAKER	27	RELEASE VALVE (oil pressure)	19
CONTROL CABLES	81	SIDE PANEL	73
CONTROLS	79	SIDE STAND	47
CRANKCASE	17	SPARK PLUGS	87
CRANKSHAFT	15	SPEEDOMETER	85
CYLINDER BLOCK	25	SPEEDOMETER CABLE	85
CYLINDER HEAD	21	SPEEDOMETER GEARBOX	61
DIRECTION INDICATORS	77, 89	STEERING HEAD BEARINGS	55
EXHAUST PIPES	53	SUSPENSION UNITS	49
EXHAUST PIPE ADAPTOR	21	SWINGING FORKS, REAR	49
ELECTRICAL EQUIPMENT	87, 89	SWITCHES (handlebar)	79
ENGINE MOUNTING PLATES	47, 51	STARTER MOTOR	37
FENDERS	75	TACHOMETER	85
FOOT PEGS	51, 53	TACHOMETER DRIVE UNIT	85
FRAME	47	TACHOMETER CABLE	85
FRONT BRAKE	59	TAPPETS	25
FRONT FORKS	55	TIMING GEARS	15
FRONT WHEEL	57	TOOLKIT	83
GAS TANK	67	TRANSMISSION (GEARBOX)	35
GEARSHIFT MECHANISM	33	VALVES	21
GEAR INDICATOR SWITCH (NEUTRAL)	87	VALVE GUIDES	21
HANDLEBARS	79	VALVE SPRINGS	21
HANDLEBAR MOUNTINGS	79	WARNING LITES	89
HEADLITE	89	WIRING HARNESS	89
HEAT SINK	87	ZENER DIODE	87
HORN	87		

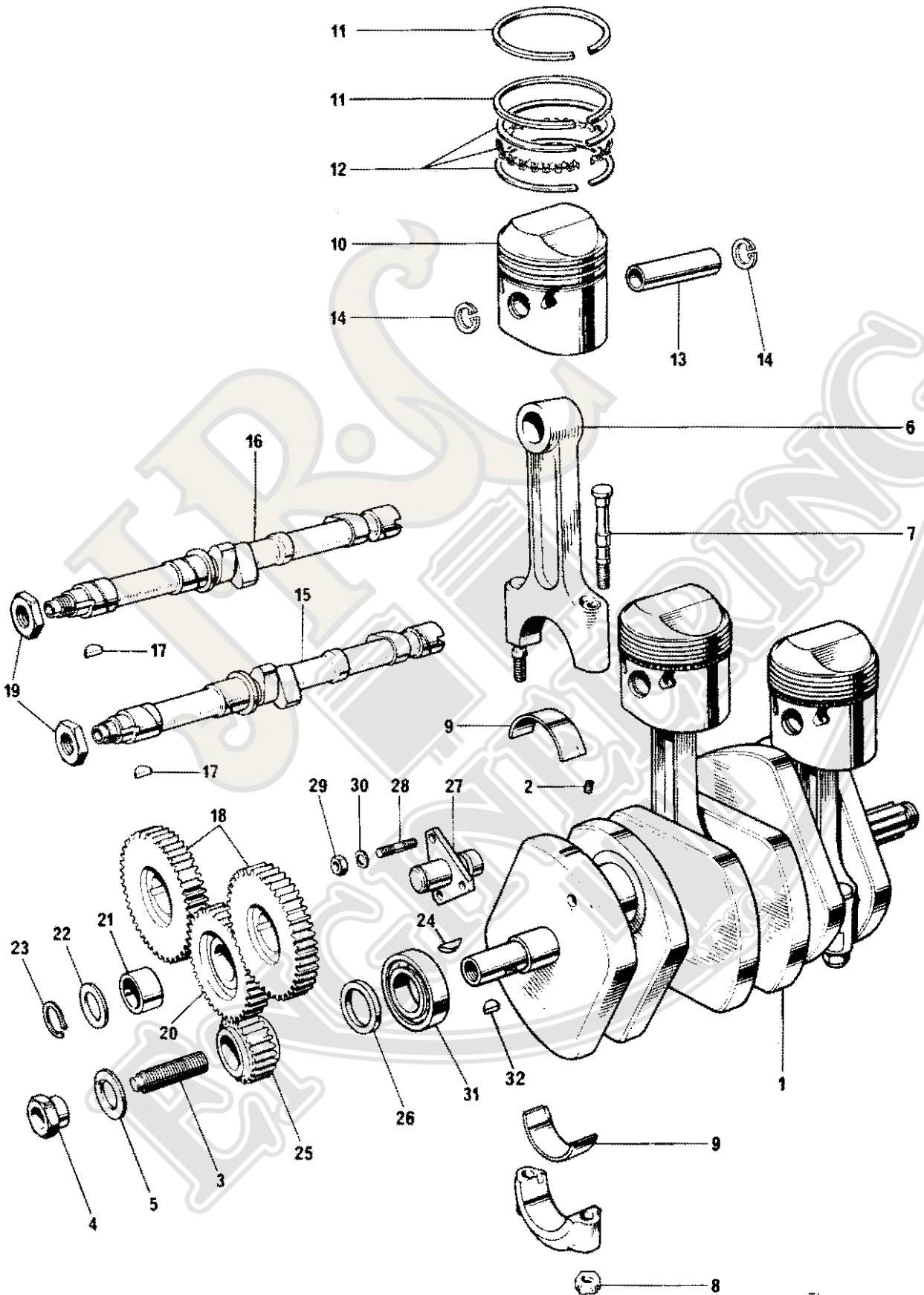

Fig. 1. CRANKSHAFT AND CONNECTING RODS

Ref. No.	Part No.	DESCRIPTION	QUANTITY	REMARKS
CRANKSHAFT AND CONNECTING RODS				
1	71-3307	Crankshaft assembly	1	
2	70-6577	Oilway plug	1	
3	21-2185	Rotor stud $\frac{7}{8}$ " U.N.F. \times 1.62"	1	
4	21-2182	Rotor nut	1	
5	70-3975	Washer, rotor nut	1	
6	70-9740	Connecting rod assembly (less thin-wall bearings)	3	
7	70-9727	†† Bolt-connecting rod cap	6	
8	60-3761	Nut—connecting rod bolt ($\frac{5}{8}$ U.N.F., self locking)	6	'Lester' star nut
9	70-5998*	Bearing—connecting rod big-end	6	halves
10	70-9741†	Piston assembly.	3	
11	70-6838†	Compression ring—taper	6	
12	70-9739†	Scraper ring	3	
13	70-6836	Wrist pin (gudgeon pin)	3	
14	70-6840	Circlip	6	
15	71-3596	Camshaft—exhaust	1	
16	70-8764	Camshaft—intake	1	
17	70-1558	Key—camshaft pinion	2	
18	71-2718	Pinion—camshaft	2	
19	70-6523	Nut—camshaft pinion	2	
20	71-2246	Timing gear—intermediate	1	
21	71-2248	Bush—timing gear	1	
22	70-6088	Thrust washer—timing gear	1	
23	70-8768	Circlip, retaining—timing gear	1	
24	70-1580	Key—crankshaft timing pinion	1	
25	70-6524	Pinion—crankshaft	1	
26	70-6173	Distance piece—crankshaft pinion	1	
27	71-2250	Spindle—intermediate timing gear	1	
28	21-0547	Stud—intermediate timing gear spindle ($\frac{1}{4}$ U.N.F./U.N.F. $\frac{27}{32}$)	3	
29	14-0401	Nut—spindle stud ($\frac{1}{4}$ U.N.F. thin)	3	
30	60-4250	Washer—spindle stud (.270" —.41" —.064")	3	
31	70-8780	Main bearing (roller), crankshaft T.S.	1	
32	70-8144	Key—alternator rotor, crankshaft	1	

*See page 8 for undersizes

†See page 8 for oversizes

††Special materials to Brit. Std. 3111, Type 2.

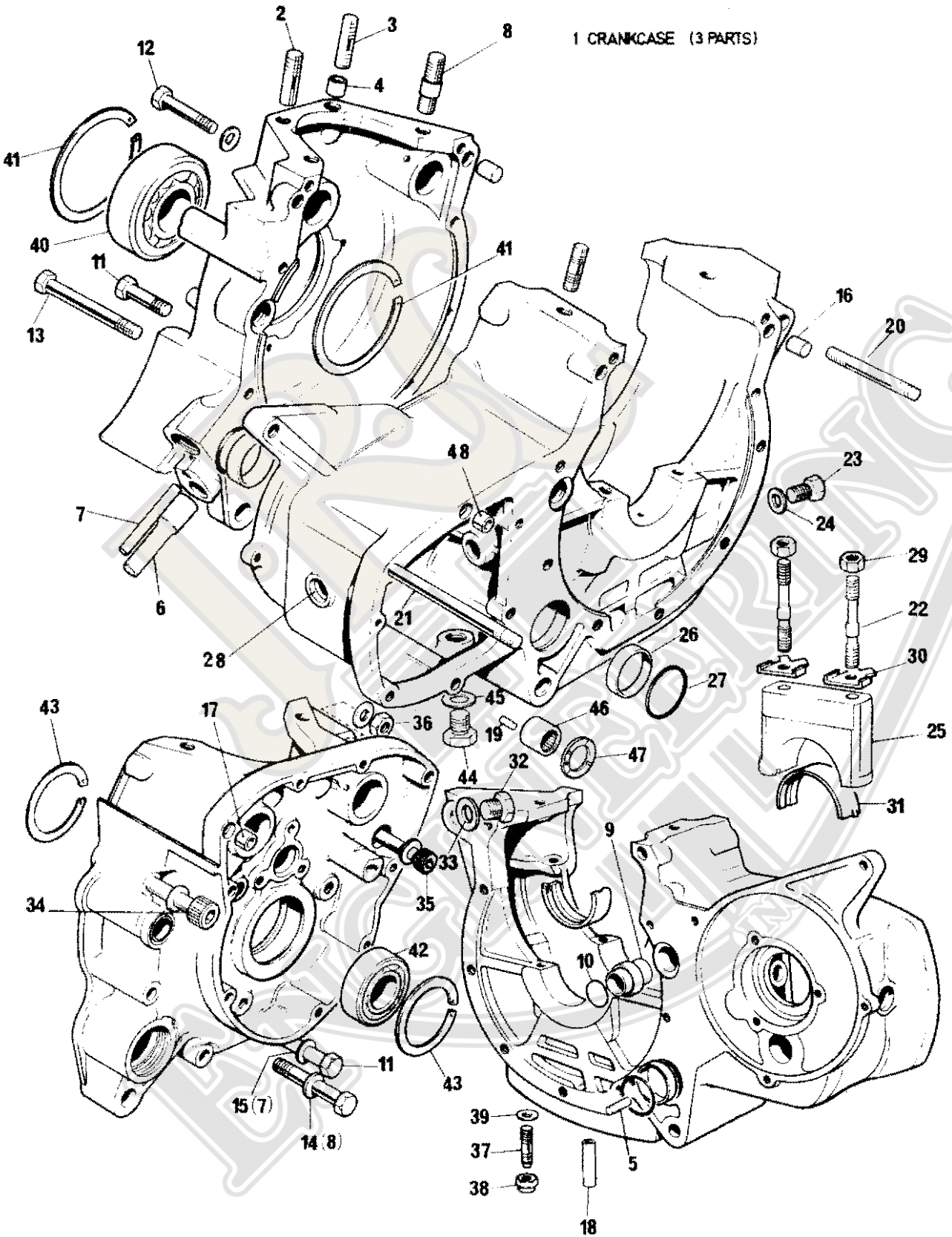

Fig. 2. CRANKCASE

Ref. No.	Part No.	DESCRIPTION	QUANTITY	REMARKS
CRANKCASE				
1	71-3641	Crankcase (T.S., D.S., and center, assembled)	1	Not supplied as separate parts.
2	21-1931	Stud—cylinder base ($\frac{3}{8}$ U.N.F./U.N.C. $\times 1\frac{1}{4}$ "	4	
3	70-8738	Stud—cylinder base, at dowel ($\frac{3}{8}$ U.N.F./U.N.C. $\times 1\frac{1}{2}$ "	2	
4	70-8751	Dowel—cylinder base location	2	
5	70-1532	Dowel—Oil pump to crankcase location	1	
6	70-6573	Pipe—oil return	1	
7	71-4433	Pipe—oil feed	1	
8	21-1912	Stud—cylinder base ($\frac{3}{8}$ U.N.F./U.N.C. $\times 1\frac{3}{2}$ "	4	$\frac{7}{16}$ " center diam.
9	71-4122	Housing—cross shaft oil seal	2	
10	60-4419	'O' ring—cross shaft seal	3	
11	14-6218	Bolt—clamping—($\frac{5}{16}$ U.N.C. $\times 1\frac{3}{8}$ " U.H.)	2	
12	14-6220	Bolt—clamping—D.S. ($\frac{5}{16}$ U.N.C. $\times 1\frac{3}{8}$ " U.H.)	2	
13	14-6226	Bolt—clamping—($\frac{5}{16}$ U.N.C. $\times 3\frac{1}{4}$ " U.H.)	9	
14	60-4247	Washer—clamping bolts (-343"—625"—062")	8	
15	60-2330	Washer—clamping bolts (-333"—625"—040")	7	
16	70-8774	Dowel, T.S. and D.S.	4	
17	57-0989	Dowel, tubular—timing cover location	2	
18	70-6578	Scavenge tube—crankcase filter	1	
19	57-0912	Peg, thrust washer—layshaft bearing D.S.	1	
20	14-1427	Stud—crankcase T.S. ($\frac{5}{16}$ U.N.C./U.N.F. $\times 3$ "	2	
21	21-1813	Stud—gearbox inner cover ($\frac{5}{16}$ U.N.C./U.N.F. $\times 4\frac{3}{4}$ "	2	
22	70-8745	**Stud—main bearing cap ($\frac{3}{8}$ U.N.C./U.N.F. $\times 4.92$ "	4	
23	14-6113	Plug—main bearing oilway ($\frac{5}{16}$ U.N.C. $\times \frac{3}{8}$ " U.H.)	2	
24	70-8776	Washer—oilway plug (-328"—687"—062, aluminum)	2	
25	71-3208	Cap—Main bearing	2	Not supplied separately
26	70-9856	Sleeve—filter 'O' ring	2	
27	71-1070	'O' ring, filter sleeve	2	
28	57-1920	Plug—blanking	1	
29	14-0303	Nut—Main bearing cap stud ($\frac{3}{8}$ U.N.F.)	4	
30	71-1129	Washer, tab—main bearing cap stud	4	
31	70-6023	†Bearing—main	4 halves	
32	70-8755	Plug—timing aperture	1	
33	70-1523	Washer, timing plug (-562"—843"—062", fiber)	1	
34	14-7026	*Screw, allen—clamping ($\frac{5}{16}$ U.N.C. $\times 2\frac{1}{2}$ " U.H.)	1	Socket head
35	21-0678	*Screw, allen—clamping ($\frac{5}{16}$ U.N.F. $\times 4$ " U.H.)	1	Socket head
36	14-0302	Nut—clamping bolts ($\frac{5}{16}$ U.N.F.)	2	
37	71-1349	Stud—sump plate ($\frac{1}{4}$ " U.N.C./U.N.F. $\times 1.19$ "	6	
38	14-1301	Nut—sump plate stud ($\frac{1}{4}$ " U.N.F., self locking)	6	
39	60-2320	Washer—sump plate nut (-265"—562"—056")	6	
40	70-1591	Bearing, main—drive side	1	
41	70-6025	Circlip—main bearing, D.S.	2	
42	70-8780	Bearing, main—timing side	1	
43	70-6026	Circlip—main bearing, T.S.	2	
44	21-1872	Drain plug—transmission (gearbox)	1	
45	70-8896	Washer, drain plug (-480"—750"—032", aluminum)	1	
46	57-1606	Bearing—needle roller, transmission layshaft	1	
47	57-1607	Thrust washer—needle roller bearing	1	
48	57-0989	Dowel, tubular—gearbox inner cover location	2	

* Special Material. Brit. Std. EN8

† See page 8 for undersizes

** Special Material. Brit. Std. EN16T

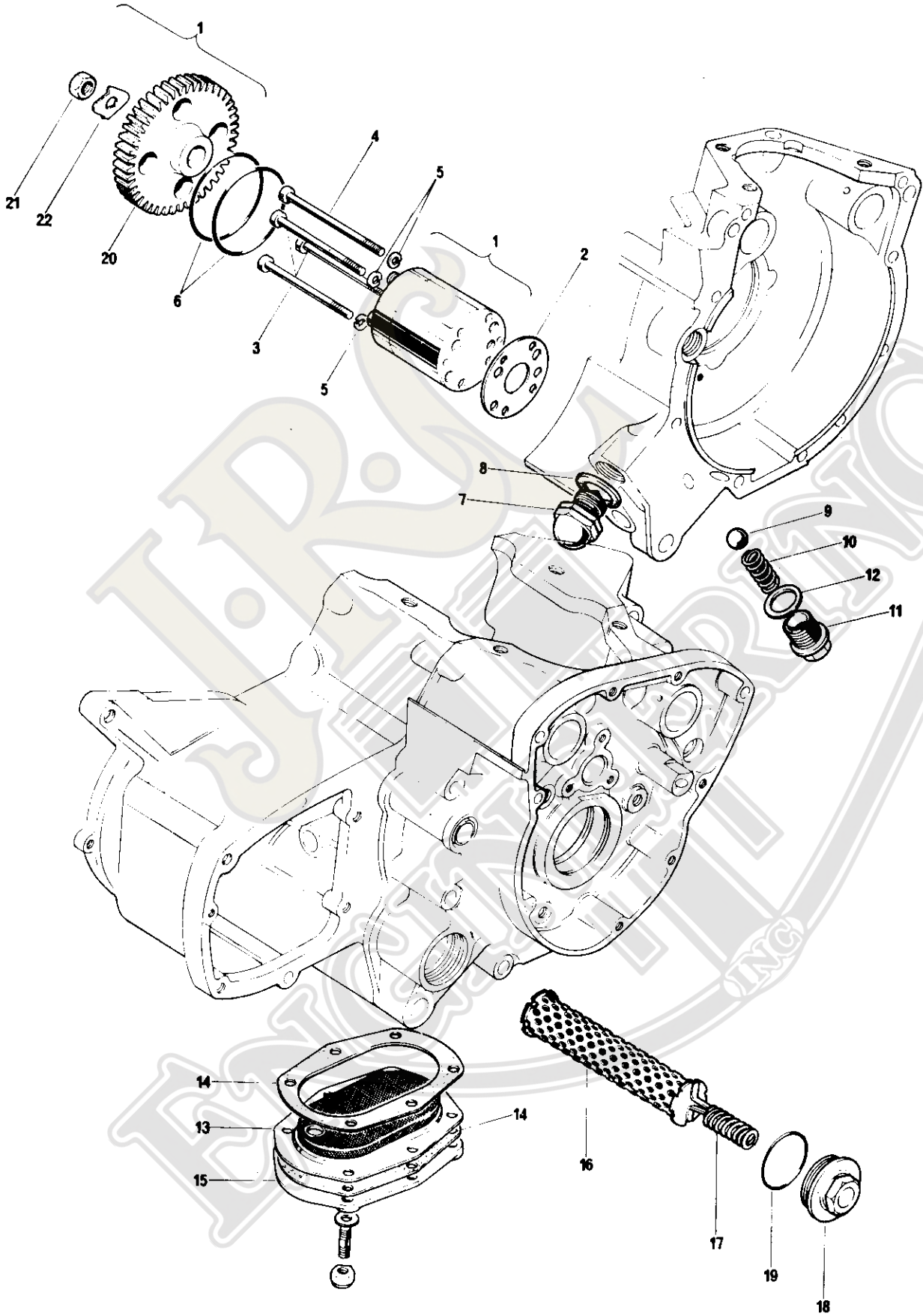

Fig. 3. OIL PUMP AND CRANKCASE FILTERS

Ref. No.	Part No.	DESCRIPTION	QUANTITY	REMARKS
OIL PUMP AND CRANKCASE FILTERS				
1	71-1351	Oil pump, assembly	1	
2	71-1442	Gasket—oil pump to crankcase	1	
3	21-2309	Screw—pump to crankcase (No. 10 U.N.C. x 2.5" U.H.) ...	3	
4	21-2310	Screw—pump to crankcase, dowel position (No. 10 U.N.C. x 2.75 U.H.)	1	
5	70-8732	Washer, spring (.192"—.320"—.064")	4	
6	70-6570	Seal—oil pump to crankcase	2	
7	70-6595	Oil pressure release valve	1	
8	70-1670	Washer—release valve to crankcase (.860"—1.12"—.032", fiber)	1	
9	60-2370	Ball—oil control valve ($\frac{7}{8}$ " diam.)	1	
10	70-6567	Spring—oil control valve	1	
11	70-6584	Body—oil control valve	1	
12	71-2792	Washer—control valve to crankcase (copper)	1	"rolled-up"
13	70-6501	Filter assembly—scavenge	1	
14	71-1444	Gasket—scavenge filter	2	
15	70-6580	Cover plate—scavenge filter	1	
16	70-6571	Element—main oil filter	1	
17	70-6130	Spring—main oil filter	1	
18	71-1270	Cap—oil filter housing	1	
19	71-1070	'O' ring—oil filter cap	1	
20	71-4237	Driven gear—oil pump	1	
21	14-0402	Nut—driven gear	1	
22	71-1353	Washer, locking.	1	

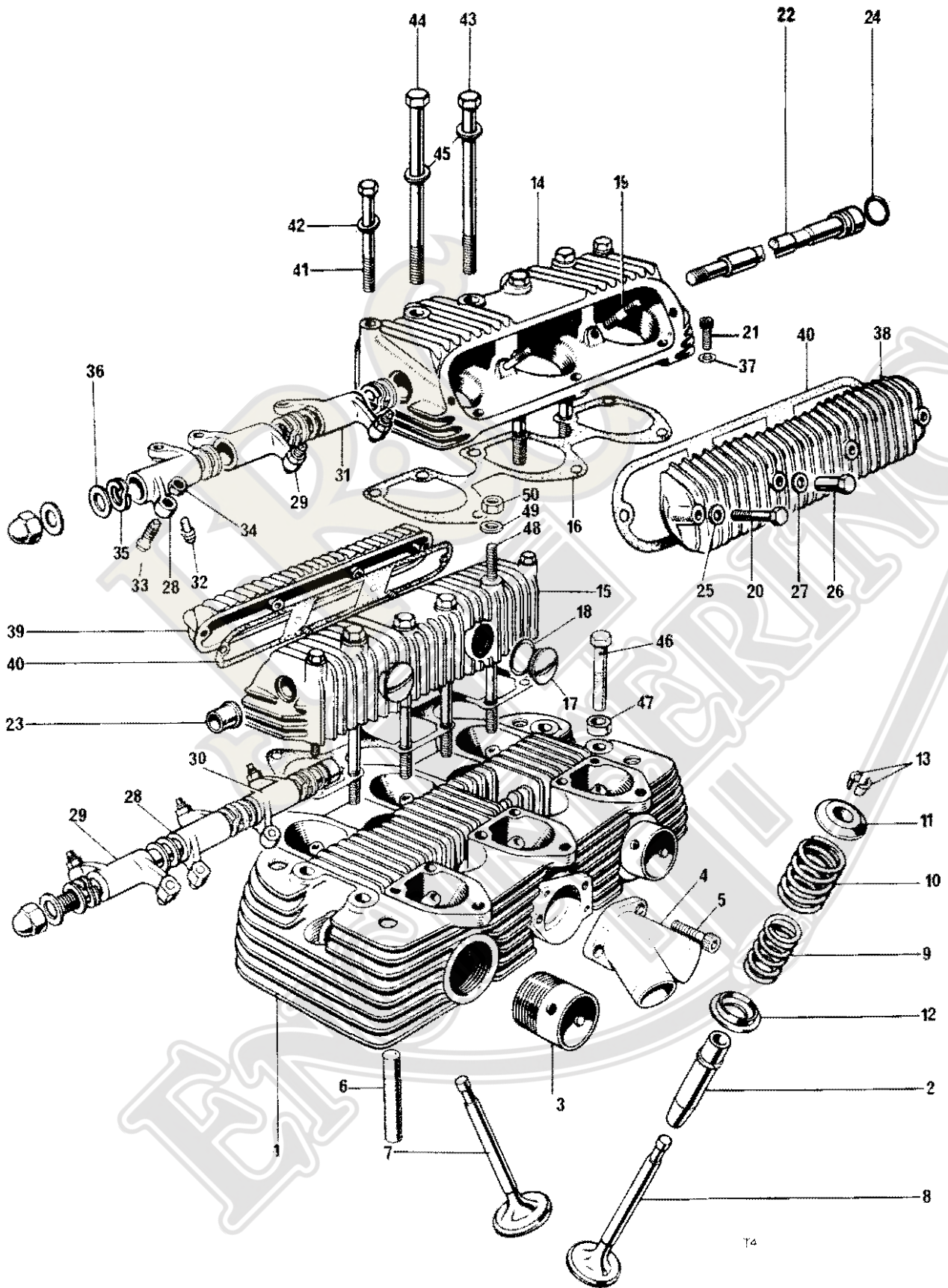
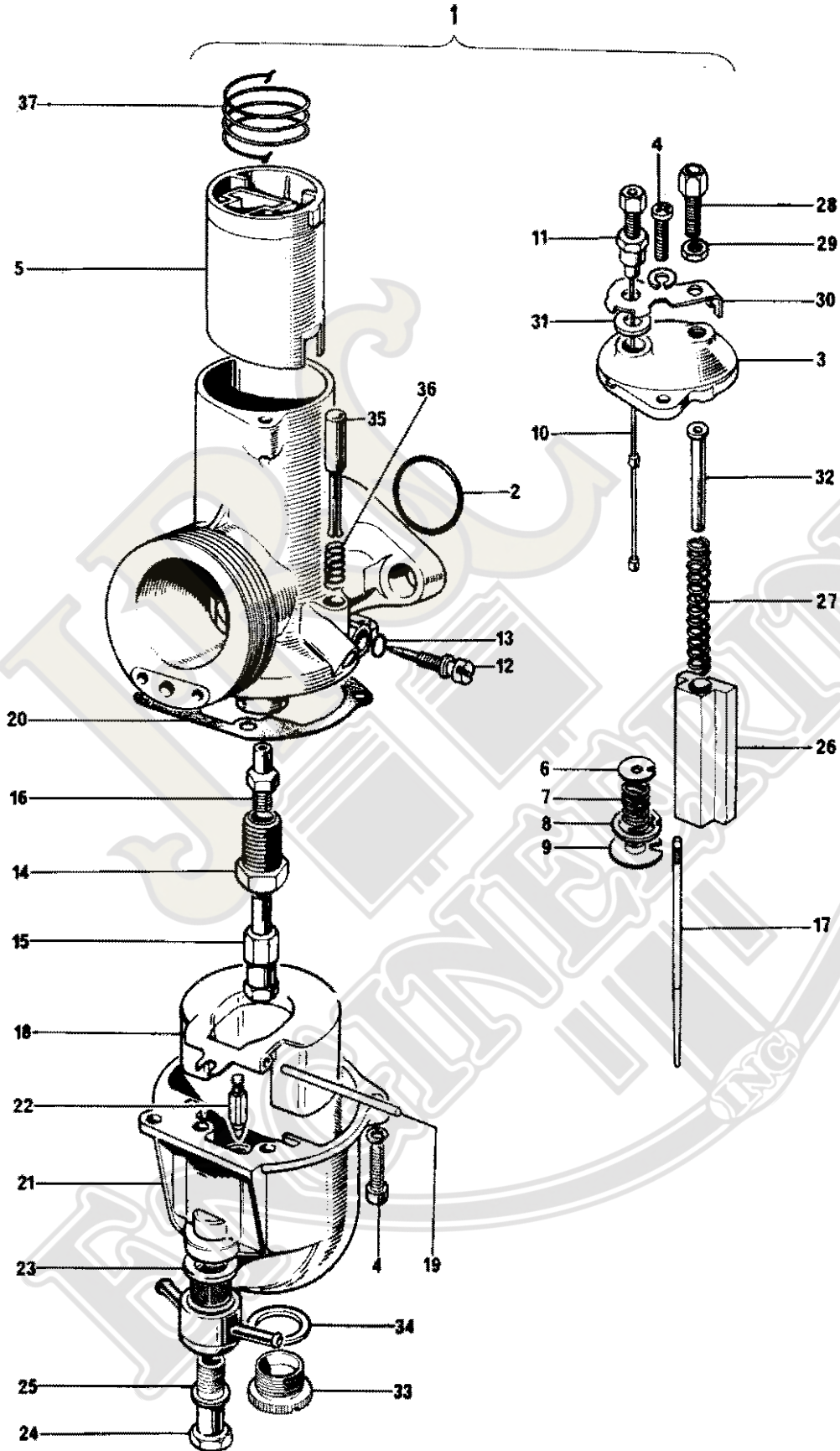

Fig. 4. CYLINDER HEAD AND ROCKER BOXES

Ref. No.	Part No.	DESCRIPTION	QUANTITY	REMARKS
CYLINDER HEAD AND ROCKER BOXES				
1	71-4356	Cylinder Head	1	
2	70-6420	*Valve Guides	6	
3	70-9510	Exhaust pipe adaptor	2	
4	71-4358	Exhaust manifold, center	1	
5	14-7004	Screw, center exhaust manifold ($\frac{1}{4}$ " U.N.C. \times $\frac{3}{4}$ " U.H.)	2	Socket Head.
6	71-4098	Fin snub rubber (also used on cylinder block)	8	
7	71-3361	Intake valve	3	
8	71-3362	Exhaust valve	3	
9	70-8787	Valve spring, inner (white/red paint spots)	6	
10	70-8788	Valve spring, outer (white/red paint spots)	6	
11	70-8720	Top collar—valve spring	6	
12	70-8789	Bottom cup—valve spring	6	
13	71-3748	Split cotter—intake and exhaust valves	12	6 pairs
14	71-4246	Rocker box—exhaust	1	
15	71-4245	Rocker box—intake	1	
16	70-8773	Gasket—rocker box	2	
17	57-2166	Cap—rocker box	4	
18	70-8782	'O' ring—rocker box cap	4	
19	14-1401	Stud—rocker box cover ($\frac{1}{4}$ " U.N.F./U.N.C. \times 1")	4	
20	14-0202	Bolt—rocker box cover ($\frac{1}{2}$ " U.N.F. \times $1\frac{1}{8}$ " U.H.)	4	
21	14-7004	Screw—rocker box to cylinder head ($\frac{1}{4}$ " U.N.C. \times $\frac{3}{4}$ " U.H.)	6	Socket head
22	70-9558	Rocker spindle	2	
23	70-6018	Bush—rocker spindle, timing side	2	
24	60-3548	'O' ring—rocker spindle bush driving side... ..	2	
25	60-4245	Washer—rocker box cover bolt (-250"—562"—078")	4	
26	70-9237	Sleeve nut—rocker box cover	4	
27	70-9239	Washer—sleeve nut	4	
28	71-3588	Rocker lever, inlet (center), exhaust (timing side)	2	
29	71-3587	Rocker lever, inlet (timing side), exhaust (center)	2	
30	71-3590	Rocker lever, inlet (driving side)	1	
31	71-3589	Rocker lever, exhaust (driving side)	1	
32	71-0070	Ball pin, rocker lever	6	
33	71-3358	Adjusting screw	6	
34	14-0402	Locknut, adjusting screw ($\frac{5}{16}$ " U.N.F., self locking)	6	
35	70-1574	Washer, thackeray—rocker spindle	6	
36	70-1575	Washer, plain—rocker spindle (-515"—750"—032")	12	Hard rolled
37	70-8175	Washer, for rocker box/cylinder. head screw	6	
38	70-6564	Inspection cover, exhaust rocker box	1	
39	70-6563	Inspection cover, intake rocker box	1	
40	71-1445	Gasket—inspection cover	2	
41	14-6211	Bolt—rocker box to cylinder head ($\frac{1}{4}$ " U.N.C. \times 3" U.H.)	4	
42	60-4245	Washer-rocker box bolt (-250" \times 562"—078")	4	
43	70-8820	Bolt, short—rocker box to cyl. block, ($\frac{5}{16}$ " U.N.F. \times $4\frac{3}{4}$ ")	4	
44	70-8819	Bolt, long—rocker box to cyl. block ($\frac{5}{16}$ " U.N.F. \times $4\frac{1}{2}$ ")	3	
45	70-9240	Washer—cylinder head bolts (-328"—625"—093")	8	
46	14-0222	Bolt—cylinder head to block ($\frac{5}{16}$ " U.N.F. \times $2\frac{1}{4}$ " U.H.)	4	
47	97-2123	Washer—cylinder head bolts (-317"—625"—156")	4	
48	21-2341	Bolt—rocker box to cylinder barrel (extended)	1	
49	14-0302	Nut—ground (earth) tags ($\frac{5}{16}$ " U.N.F.)	1	
50	60-2321	Washer, for nut (-333"—625"—072")	1	

*For oversizes see page 8



TS
Fig. 5. CARBURETORS

Ref. No.	Triumph Part No.	Maker's Part No.	DESCRIPTION	QUANTITY	REMARKS
CARBURETORS					
1	60-4572	626/76	Carburetor R.H. (Complete) ...	1	
1	60-4572	626/76	Carburetor, Center (Complete) ...	1	
1	60-4571	626/77	Carburetor, L.H. (Complete) ...	1	
2	99-0522	622/101	'O' ring, flange seal ...	1	} Each carburetor
3	99-1049	622/097	Mixing chamber top ...	1	
4	99-0521	622/086	Screw—float chamber and mixing chamber top	4	
5		622/060/4	Throttle valve (4 cutaway) ...	1	
6	60-1959	622/115	Retaining cap ...	1	
7	60-1960	622/113	Retainer spring ...	1	
8	99-0510	622/067	Needle clip ...	1	
9	60-1987	622/116	Retaining plate—needle clip ...	1	
10	60-4315	244/2283	Throttle valve rod ...	1	
11	97-0745	295/014	Locknut—throttle valve rod ...	1	
12	99-0515	622/076	Pilot air adjuster screw ...	1	
13	99-0520	622/082	'O' ring—pilot air screw ...	1	
14	99-1034	622/128	Jet holder ...	1	
15	99-1020	376/100	Main jet—150 ...	1	
16	99-1035	622/122	Needle jet—106 ...	1	
17		622/278	Throttle needle ...	1	
18	99-0512	622/069	Float ...	1	
19	99-0513	622/071	Float spindle ...	1	
20	99-0514	622/073	Float chamber joint washer ...	1	
21		622/055	Float chamber body ...	1	
22	99-0511	622/068	Float needle ...	1	
23	99-0438	376/093	Filter ...	1	
24	99-0517	622/078	Banjo bolt ...	1	
25	99-1100	13/163	Washer, banjo bolt—fiber ...	1	
26	99-1021	622/062	Air valve ...	1	
27		622/186	Air valve spring ...	1	
28	19-2711	4/035	Cable adjuster ...	1	
29	99-0224	5/077	Locknut—cable adjuster ...	1	
30	99-1022	622/125	Locating clip—sealing washer ...	1	
31	99-1023	622/126	Sealing washer ...	1	
32	99-1051	622/134	Air valve guide ...	1	
33	99-1152	622/147	Float chamber drain plug ...	1	
34	99-1153	622/151	Washer—drain plug ...	1	
35		1034/172	Tickler, complete ...	1	
36		1034/073	Tickler spring ...	1	
37	60-4573	622/277	Throttle valve spring ...	1	

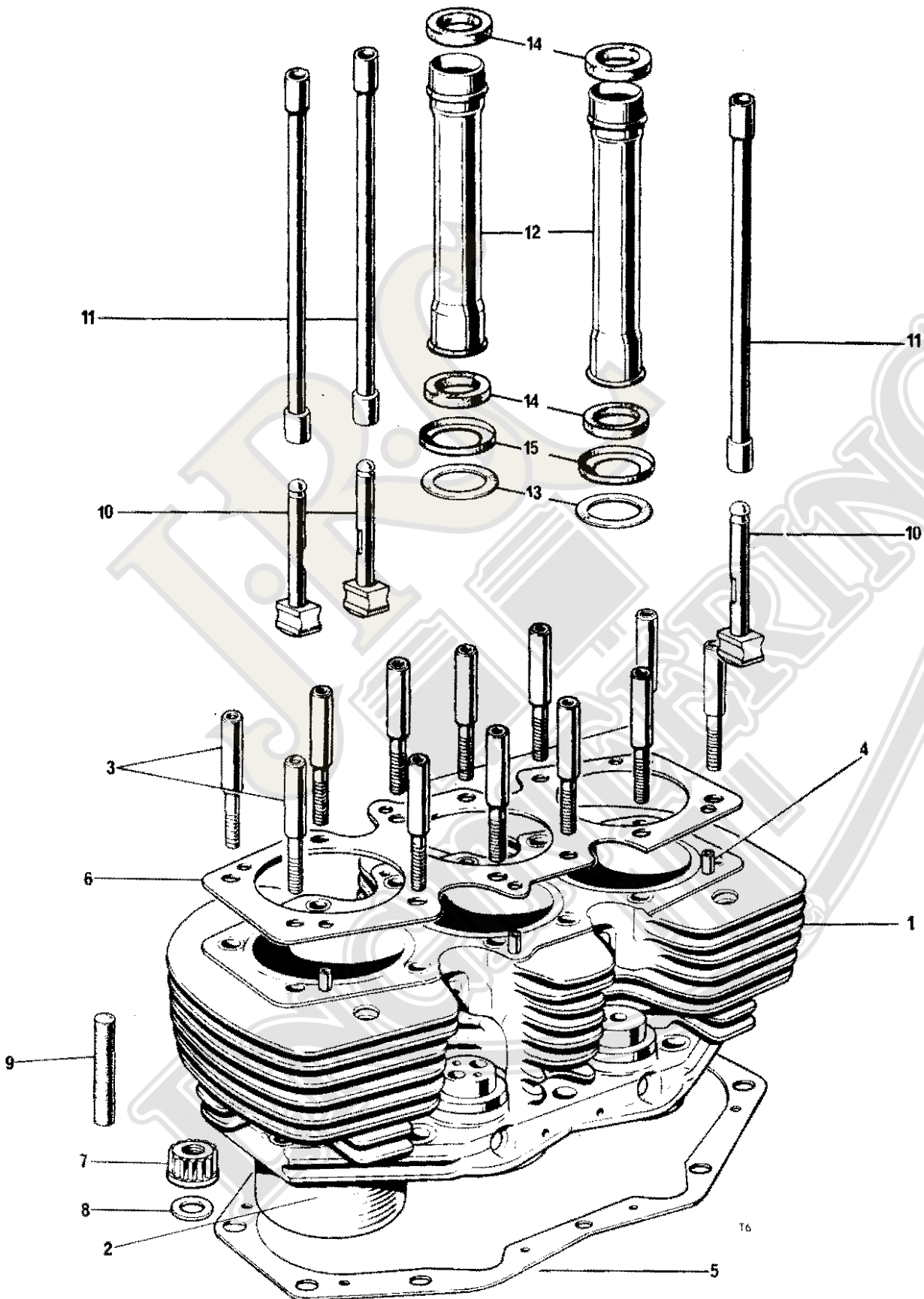

Fig. 6. CYLINDER BLOCK, PUSH RODS, TAPPETS

Ref. No.	Part No.	DESCRIPTION	QUANTITY	REMARKS
CYLINDER BLOCK, PUSH RODS, TAPPETS				
1	71-3935*	*Cylinder block, with liners and tappet guides	1	
2	70-8914	Cylinder liner	3	
3	70-8817	Pillar stud—cylinder block	12	
4	70-1532	Dowel—cylinder block to head	4	
5	70-6496	Cylinder block base gasket	1	
6	71-4250*	Cylinder head gasket	1	
7	21-0692	Cylinder block base nut	10	"Twelve point"
8	70-8770	Washer—cylinder block base nut (.390"—.625"—.064")	10	
9	71-4098	Fin snub rubber (also used on cylinder head)	4	
10	71-3976	Tappet	6	
11	71-3974	Push rod	6	
12	71-4378	Cover tube—push rod	4	
13	71-1190	Gasket—push rod cover tube	4	
14	70-4752	Sealing rubber—push rod cover tube	8	
15	70-4746	Bottom cup—sealing rubber	4	

*Copper, to Brit. Std. 2870.C102-0. Annealed to 45 H.V. Max.

**For oversizes, See Page 8.

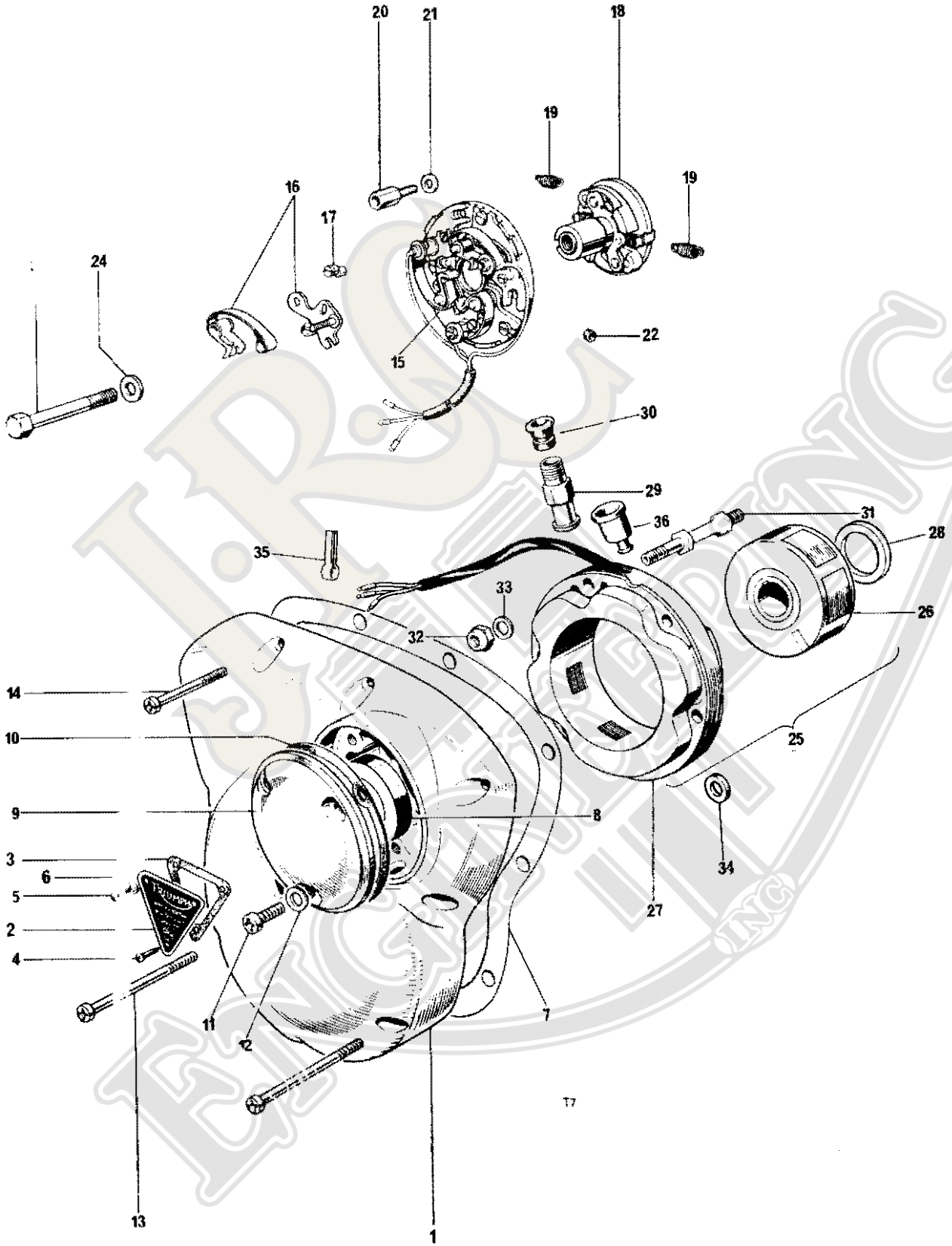

Fig. 7. TIMING COVER AND CONTACT BREAKER

Ref. No.	Triumph Part No.	Makers Part No.	DESCRIPTION	QUANTITY	REMARKS
TIMING COVER AND CONTACT BREAKER					
1	70-6432		Timing Cover	1	
2	70-8762		Cover—timing aperture	1	
3	71-1440		Gasket—timing aperture cover	1	
4	71-4434		Screw—pointer, aperture cover	1	
5	71-0007		Screw—aperture cover (4BA × $\frac{5}{8}$ "...)	2	Round head
6	70-9266		Washer—aperture cover screw (.156"—.250"—.032")	3	
7	71-1350		Gasket—timing cover to crankcase	1	
8	70-4568		Oil seal—contact breaker	1	
9	70-6519		Cover—contact breaker	1	
10	71-1441		Gasket—contact breaker cover	1	
11	82-4715		Screw—contact breaker cover (2 BA × .44" U.H.)...	3	Cheesehead
12	97-0430		Washer—contact breaker cover screw (.203"—.375 — .060")	3	
13	14-6612		Screw—timing cover to crankcase ($\frac{1}{4}$ " U.N.C. × 2" U.H.)	3	
14	14-6608		Screw—timing cover to crankcase ($\frac{1}{4}$ " U.N.C. × 1" U.H.)	6	
15	99-1233	54419327	Contact breaker, complete with leads (Type 7 CA)	1	
16	99-1014	54419828	Contact points set	1	
17	99-0769	54419220	Adjusting screw	3	
18	99-1015	54419867	Auto-advance unit	1	
19	19-1958	60600459	Springs—(supplied in pairs only)	2	
20	70-6521		Pillar bolt	3	
21	70-6559		Washer, for pillar bolt (.192"—.375"—.056"), fiber	3	
22	70-8756		Grommet—contact breaker	2	
23	14-0208		Bolt—contact breaker cam to camshaft	1	
24	70-8163		Washer for contact breaker bolt (.250"—.500 —.62")	1	
25		54021277	Alternator (Type RM21)	1	
26	19-1288	60600536	Rotor	1	
27	99-1016	47205	Stator	1	
28	71-4435		Spacer—rotor	0	
29	70-8760		Seal nut—alternator leads	1	
30	70-9807		Grommet—alternator leads	1	
31	70-6522		Stud—stator mounting	3	
32	21-1852		Nut—stator mounting stud, $\frac{5}{16}$ " U.N.F. (self-locking)	3	
33	60-4247		Washer, for stud nut (.343"—.625"—.062") ...	3	
34	97-2123		Distance piece—stator mounting	6	
35	70-8147		Clip, for alternator leads	1	
36	70-4144		Grommet, cable seal nut	1	

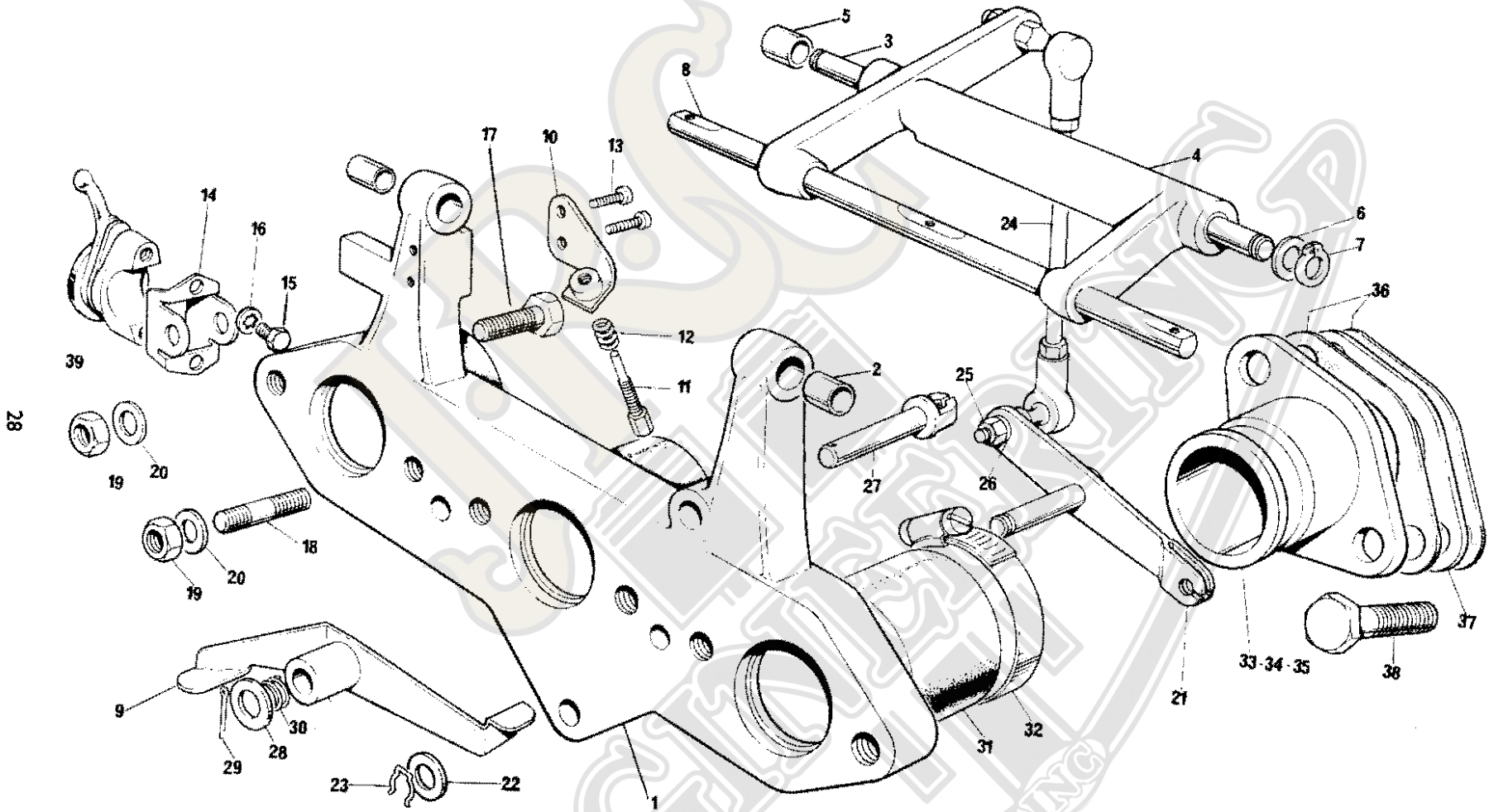

Fig. 8. CARBURETOR ADAPTOR AND THROTTLE LINKAGE

Ref. No.	Part No.	DESCRIPTION	QUANTITY	REMARKS
CARBURETOR ADAPTOR AND THROTTLE LINKAGE				
1	71-4077	Adaptor, with bushes	1	
2	70-9073	Bush	2	
3	71-4400	Spindle—operating arm	1	
4	71-3919	Operating arm—throttle linkage	1	
5	70-9073	Bush	2	
6	71-0245	Washer—operating arm spindle	2	
7	70-9255	Circlip—operating arm spindle	2	
8	71-3885	Operating bar	1	
9	71-4360	Operating arm—center tickler	1	
10	71-4082	Throttle stop plate	1	
11	71-3924	Throttle stop adjuster screw	1	
12	70-9254	Throttle stop screw spring	1	
13	21-1930	Screw—throttle stop plate (No. 10 × 32 U.N.F. × ½" U.H.)	2	
14	83-3665	Bracket—choke control lever	1	
15	60-3896	Screw—choke control lever bracket (1 BA × 40° U.H.)	2	
16	60-4256	Washer—bracket screw (shakeproof)	2	
17	14-0219	Bolt—bracket to adaptor (⅝" U.N.F. × 1½" U.H.)	1	
18	14-1619	Stud—carburetor (⅝" U.N.C./U.N.F. × 1½")	5	
19	14-1302	Nut—carburetor stud (⅝" U.N.F.)	6	
20	60-4247	Washer, for nut (.312" × .625" × .062")	6	
21	71-4078	Throttle lever	1	
22	60-2330	Washer—throttle lever (.333 × .625 × .040")	1	
23	60-4393	Circlip—throttle lever	1	
24	71-4099	Throttle link rod, assembled	1	
25	82-4717	Ball joint nut (2 BA, self-locking)	2	
26	60-2391	Washer—ball joint nut (.202"—.391"—.032")	2	
27	71-4084	Abutment pivot—throttle cable	1	
28	60-2330	Washer, plain—abutment pivot (.333"—.625"—.040")	1	
29	60-2684	Split pin—abutment pivot	1	
30	60-4596	Spring, spacer—abutment pivot	1	
31	70-9060	Connector tube—carburetor	3	
32	60-0707	Clip—carburetor pipes to adaptor	6	
33	71-3946	Inlet stub—centre carburetor	1	
34	71-4001	Inlet stub—R.H. carburetor	1	
35	71-4002	Inlet stub—L.H. carburetor	1	
36	71-3947	Gasket—carburetor stub	6	
37	71-3948	Insulating washer—stub to cylinder head	3	
38	14-7005	Screw—carburetor stub	6	
39	60-4521	Choke control lever—assembly	1	

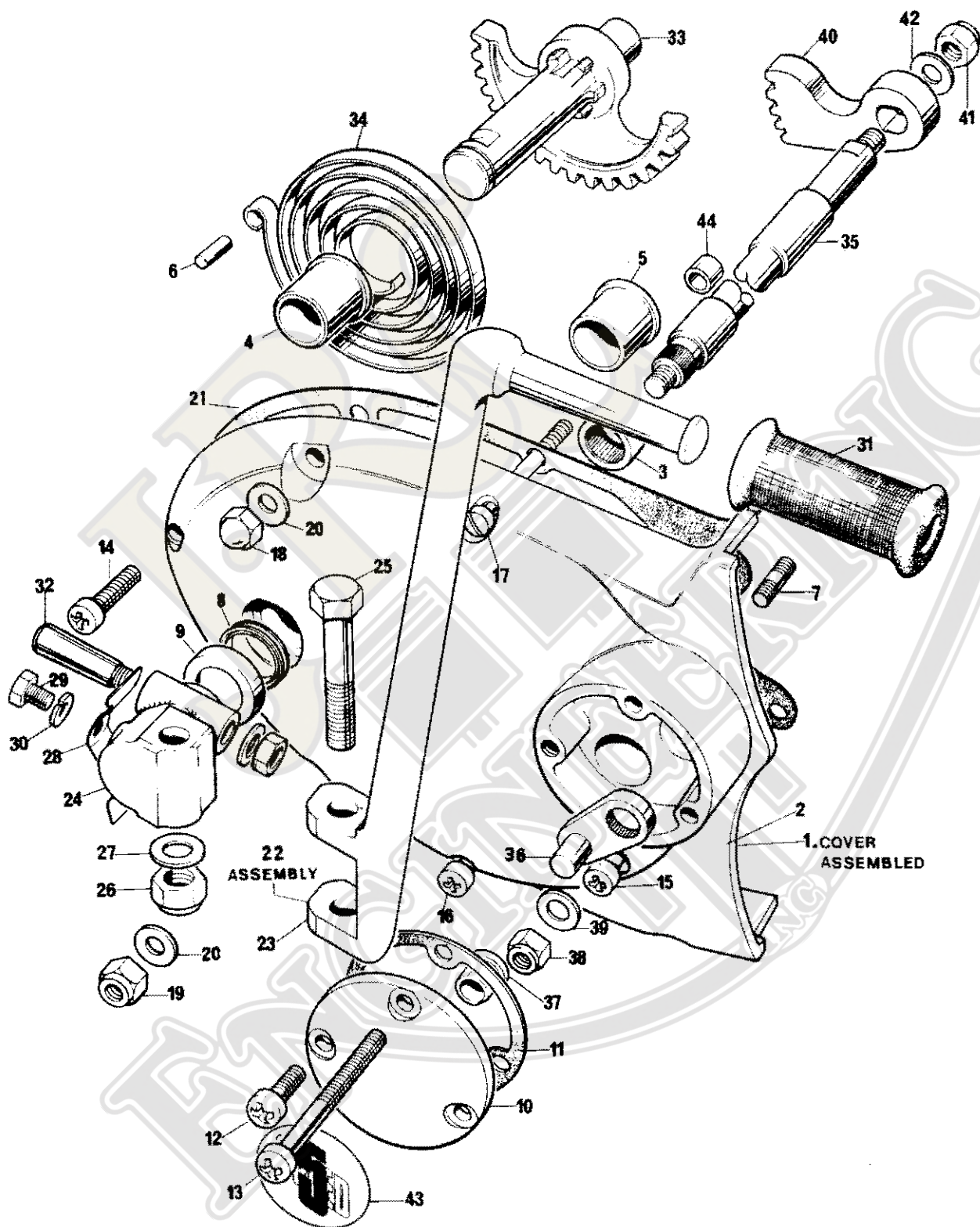

Fig. 9. TRANSMISSION (GEARBOX) OUTER COVER, GEARSHIFT LINKAGE AND KICKSTARTER PEDAL

Ref. No.	Part No.	DESCRIPTION	QUANTITY	REMARKS
TRANSMISSION (GEARBOX) OUTER COVER, GEARSHIFT LINKAGE AND KICKSTARTER PEDAL				
1	57-4891	Transmission outer cover, assembled	1	
2	57-4879	Transmission outer cover	1	
3	60-4333	Bearing—needle roller	1	
4	57-0023	Bush—foot starter shaft	1	
5	57-4700	Bush—outer	1	
6	57-0047	Anchor pin—footstart return spring	1	
7	21-0547	Stud—gear control guide plate ($\frac{1}{4}$ " U.N.C./U.N.F. \times $\frac{3}{2}$ ")	4	
8	57-1956	Oil seal—foot starter shaft	1	
9	57-1955	Housing—oil seal	1	
10	57-4702	Inspection cover—transmission outer cover	1	
11	57-4753	Gasket—inspection cover	1	
12	14-7806	Screw—inspection cover ($\frac{1}{4}$ " U.N.C. \times $\frac{3}{4}$ " U.H.)	1	
13	21-2312	Screw—inspection cover ($\frac{1}{4}$ " U.N.C. \times 3" U.H.)	2	
14	14-6608	Screw—outer cover to crankcase ($\frac{1}{4}$ " U.N.C. \times 1" U.H.)	1	
15	14-6610	Screw—outer cover to crankcase ($\frac{1}{4}$ " U.N.C. \times $1\frac{1}{2}$ " U.H.)	1	
16	14-6609	Screw—outer cover to crankcase ($\frac{1}{4}$ " U.N.C. \times $1\frac{1}{2}$ " U.H.)	1	
17	21-2140	Screw—outer and inner covers to crankcase ($\frac{1}{4}$ " U.N.C. \times $4\frac{3}{8}$ " U.H.)	1	
18	21-0544	Nut, domed—outer cover, top	1	
19	14-1302	Nut—outer cover, bottom ($\frac{5}{16}$ " U.N.F., self-locking)	1	
20	60-4247	Washer—outer cover nuts (.312"—.625"—.062")	2	
21	57-4878	Gasket—outer cover to inner cover	1	
22	57-4941	Folding kickstarter pedal assembly	1	
23	57-4904	Kickstarter lever	1	
24	57-4906	Carrier—kickstarter lever	1	
25	21-2318	Pivot bolt—kickstarter lever ($\frac{7}{16}$ " U.N.F. \times $2\frac{1}{4}$ ")	1	
26	14-1304	Nut—pivot bolt ($\frac{7}{16}$ " U.N.F., self-locking)	1	
27	60-4267	Washer—pivot bolt (.453"—.750"—.064")	1	
28	57-4861	Spring—plate	1	
29	14-0101	Bolt—plate spring ($\frac{1}{4}$ " U.N.F. \times $\frac{1}{2}$ " U.H.)	1	
30	60-2417	Washer, spring	1	
31	57-2330	Rubber—pedal	1	
32	57-4356	Cotter pin, with nut and washer	1	
33	57-4892	Shaft, kickstarter (complete with quadrant)	1	
34	57-0031	Spring—kickstarter return	1	
35	57-5114	Cross shaft—gear shift	1	
36	57-5089	Link—cross shaft, timing side	1	
37	57-4699	Bush—cross shaft link	1	
38	14-1202	Nut—link to cross shaft ($\frac{5}{16}$ " U.N.F., self-locking)	1	
39	60-2321	Washer—linknut (.333"—.625"—.072")	1	
40	57-4926	Quadrant—cross shaft, driving side	1	
41	14-1202	Nut—quadrant to cross shaft ($\frac{5}{16}$ " U.N.F., self-locking)	1	
42	60-2321	Washer, quadrant nut (.333"—.625"—.072")	1	
43	60-3748	Decal—Inspection cover	1	
44	57-4704	Spacer	1	

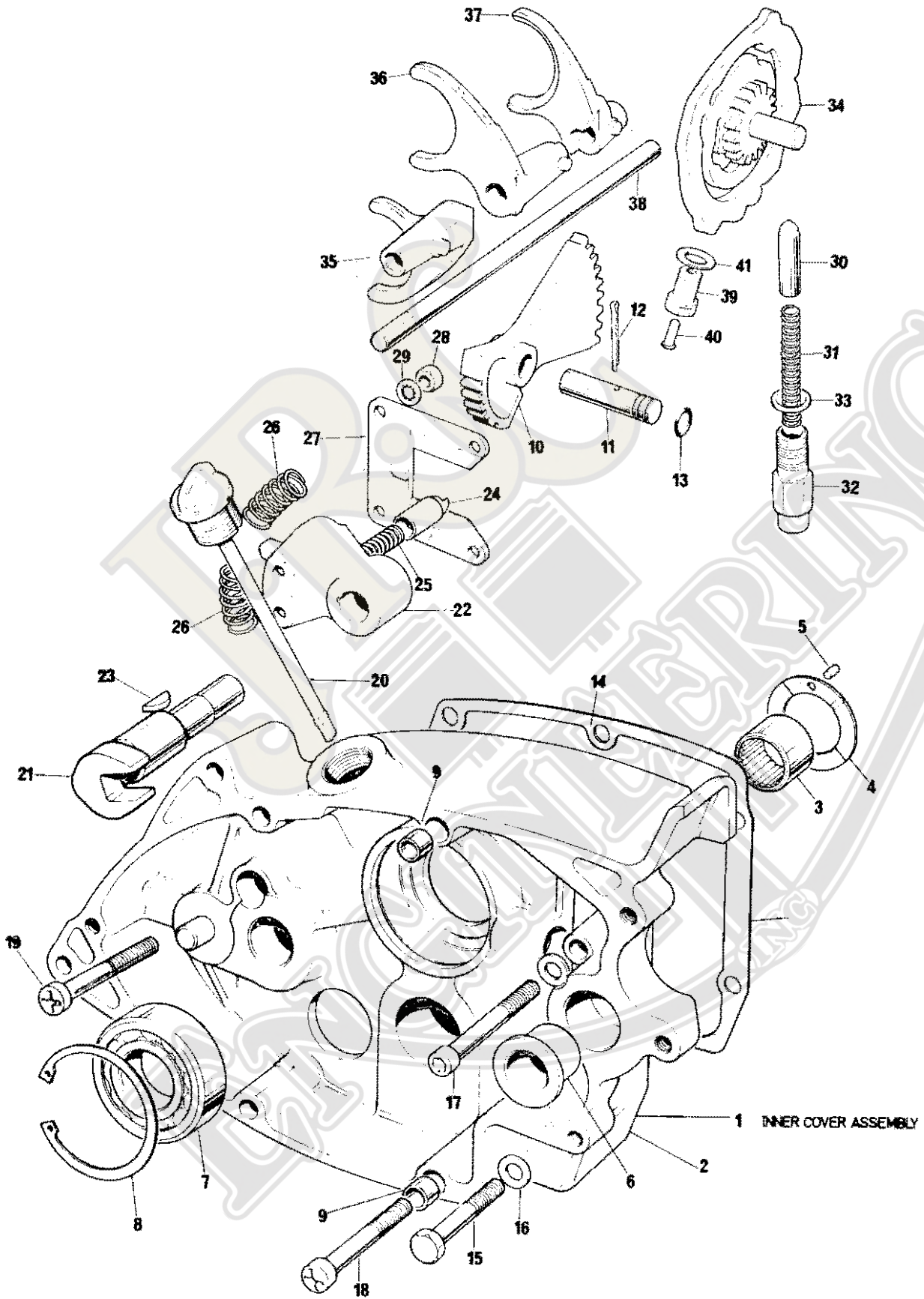

Fig. 10. TRANSMISSION (GEARBOX) INNER COVER AND GEARSHIFT MECHANISM

Ref. No. Part No. DESCRIPTION QUANTITY REMARKS

TRANSMISSION (GEARBOX) INNER COVER AND GEARSHIFT MECHANISM

1	57-4890	Transmission inner cover, assembly	1	
2	57-4768	Transmission inner cover, with foot starter buffer	1	
3	57-1614	Bearing—needle roller, layshaft	1	
4	57-1607	Thrust washer—layshaft bearing	1	
5	57-0912	Peg—thrust washer	1	
6	57-5000	Bush—gear shift fork (timing side)	1	
7	60-3552	Bearing—mainshaft (transmission)	1	
8	57-4113	Circlip—mainshaft bearing (transmission)	1	
9	57-0989	Dowel—inner cover to outer cover	2	
10	57-4363	Quadrant—gear control	1	
11	57-1896	Spindle—gear control quadrant	1	
12	60-2708	Split pin—spindle	2	
13	37-3761	'O' ring—spindle	1	
14	71-1447	Gasket—inner cover to crankcase	1	
15	14-6121	Bolt—inner cover to crankcase ($\frac{5}{16}$ " U.N.C. \times $2\frac{1}{2}$ " U.H.)	1	
16	70-3446	Washer, for bolt ($\cdot 328$ "— $\cdot 531$ "— $\cdot 048$ ")	1	
17	14-7101	Screw—inner cover to crankcase	1	Socket head
18	21-1917	Screw—inner to crankcase ($\frac{1}{4}$ " U.N.C. \times $2\frac{3}{8}$ " U.H.)	1	
19	14-6614	Screw—inner cover to crankcase ($\frac{1}{4}$ " U.N.C. \times $2\frac{1}{2}$ " U.H.)	1	
20	57-4771	Dipstick/filler cap—transmission oil level	1	
21	57-4698	Gearshift fork—timing side	1	
22	57-4881	Quadrant	1	
23	71-0037	Key—quadrant to gearshift fork shaft	1	
24	57-4403	Plunger	2	
25	57-0405	Spring—plunger	2	
26	57-0404	Spring—gearshift pedal return	2	
27	57-0407	Guide plate	1	
28	14-0301	Nut—guide plate fixing	4	
29	70-1612	Washer—for nut (internal serrations)	4	"Shakeproof"
30	57-4226	Plunger—camplate	1	
31	57-4459	Spring—camplate plunger	1	
32	57-4227	Housing—plunger spring	1	
33	57-3978	Sealing washer ($\cdot 632$ "— $\cdot 937$ "— $\cdot 028$ ") aluminum	2	
34	57-4889	Camplate	1	
35	57-4364	Selector fork—mainshaft 4th gear	1	
36	57-4366	Selector fork—layshaft 3rd gear	1	
37	57-4660	Selector fork—layshaft 1st gear	1	
38	57-3989	Shaft—selector forks	1	
39	57-5086	Adaptor—neutral switch	1	
40	57-5087	Plunger—neutral switch	1	
41	70-1523	Washer—adaptor ($\cdot 562$ "— $\cdot 844$ "— $\cdot 064$ ") Fiber	1	

34

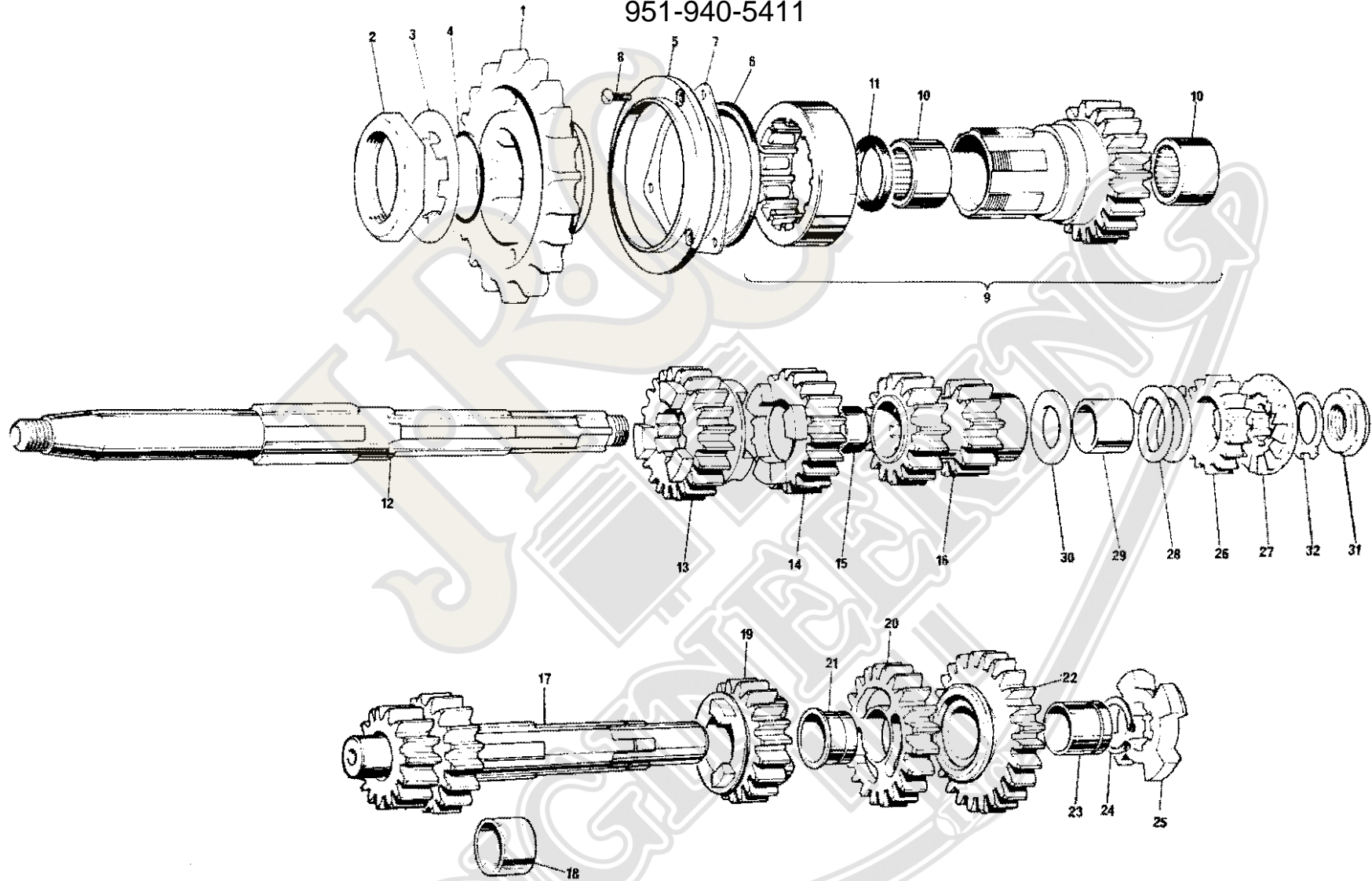

Fig. 11. TRANSMISSION (GEARBOX) SHAFTS AND GEARS

Ref. No.	Part No.	DESCRIPTION	QUANTITY	REMARKS
TRANSMISSION (GEARBOX) SHAFTS AND GEARS				
1	57-4783	Transmission sprocket (19 teeth)	1	
2	57-4396	Nut—transmission sprocket	1	
3	57-4909	Lockwasher—sprocket nut	1	
4	71-1070	'O' ring—transmission sprocket	1	
5	57-4394	Housing—oil seal	1	
6	60-3510	Oil seal... ..	1	
7	71-1451	Gasket—oil seal housing	1	
8	21-2106	Screw—oil seal housing	3	
9	57-4781	Mainshaft high gear assembly (includes main bearing, needle bearings, and oil seal)... ..	1	
10	60-3511	Bearing—needle roller	2	
11	60-3500	Oil seal	1	
12	57-4370	Mainshaft	1	
13	57-4376	Mainshaft 4th gear	1	
14	57-4377	Mainshaft 3rd gear	1	
15	57-4575	Bush—mainshaft 3rd gear.	1	
16	57-4653	Mainshaft 1st and 2nd gear	1	
17	57-4900	Layshaft assembly (includes 4th gear, circlip, and high gear)	1	
18	57-4793	Bush—layshaft 4th gear	1	
19	57-4647	Layshaft 3rd gear	1	
20	57-4657	Layshaft 2nd gear	1	
21	57-4662	Bush—layshaft 2nd gear	1	
22	57-4654	Layshaft 1st gear	1	
23	57-4663	Bush—layshaft 1st gear	1	
24	60-3494	Circlip	1	
25	57-4661	Driving dog—layshaft 1st gear	1	
26	57-0730	Pinion—kickstart	1	
27	57-0731	Ratchet—kickstart	1	
28	57-1250	Spring—kickstart ratchet	1	
29	57-1963	Sleeve—kickstart pinion	1	
30	57-1962	Washer—pinion sleeve	1	
31	21-0594	Nut—mainshaft	1	
32	57-2240	Washer, for nut	1	

NB Mainshaft high gear bearing not available as a separate item

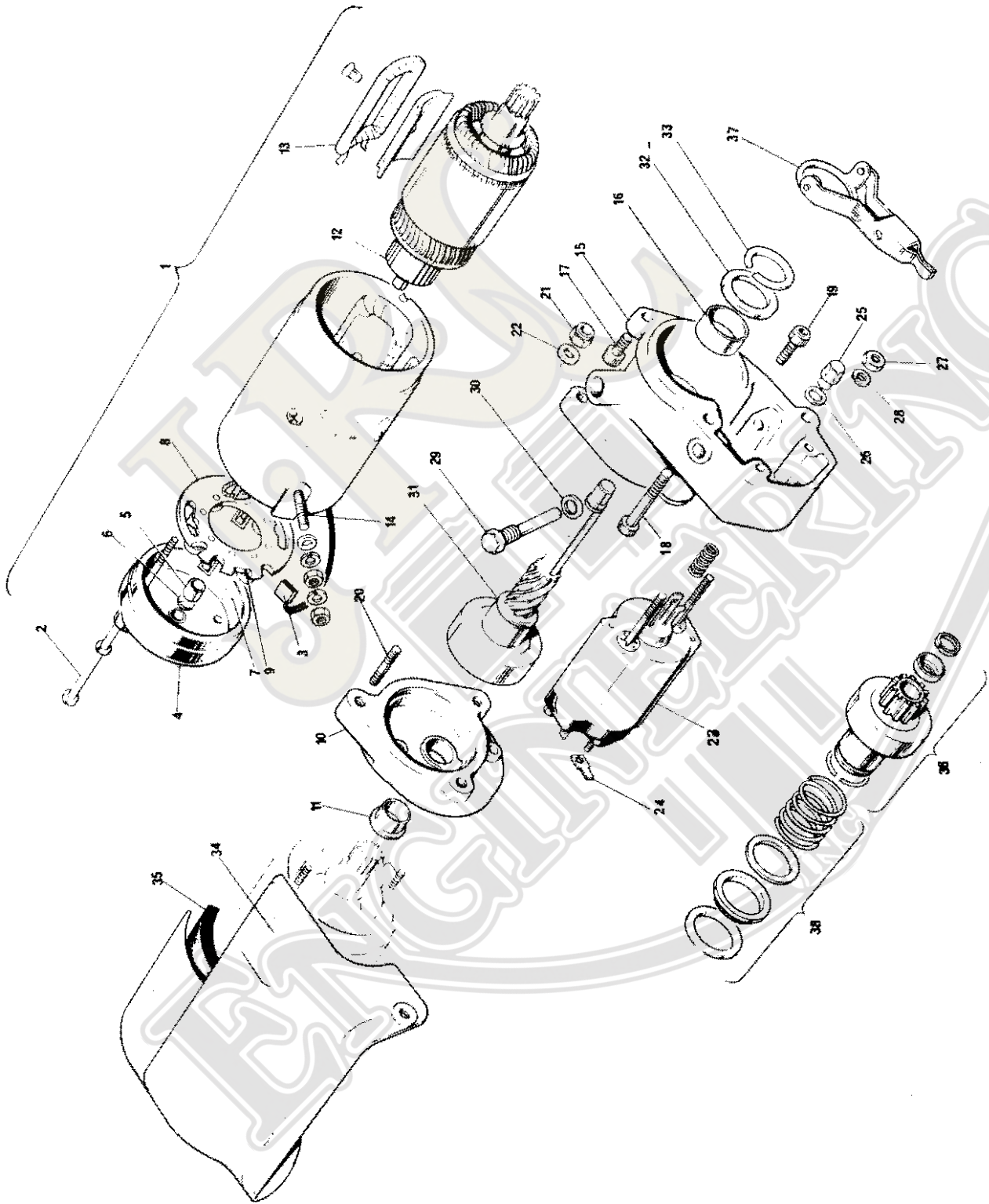

FIG. 12. ELECTRIC STARTER MECHANISM

Ref. No.	Triumph Part No.	Makers Part No.	DESCRIPTION	QUANTITY	REMARKS
ELECTRIC STARTER MECHANISM					
Not illus.	60-3990		Starter Motor (up to engine No. 05000 approx.)	1	
1	60-4211	26518A/B	Starter Motor (after engine No. 05000 approx.)	1	Type M3
2	19-1950	54254142	Bolt, through fixing	2	
3	19-1951	54255887	Brushes,	1	Set
4	19-1952	54260204	Bracket, commutator end	1	
5	19-1953	261233	Bush, bearing	1	
6		54252180	Pad, thrust	1	
7		54251728	Liner, Insulating	1	
8	19-1954	54251727	Plate c/w brush boxes and springs	1	
9	19-1955	54252360	Spring set	4	
10	71-3579	54249344	Bracket, drive end	1	
11	71-3581	54244545	Bush, bearing	1	
12	19-1956	54249341	Armature	1	
13		54256043	Field coils	1	
14		54256040	Terminal, field	1	
Not illus.	19-1957	54252417	Sundry parts, set	1	
15	71-3653		Solenoid and bearing housing	1	
16	71-3654		Bush—intermediate shaft	1	
17	14-7002		Screw—housing to clutch cover ($\frac{1}{8}$ " U.N.C. $\frac{1}{2}$ " U.H.)	2	Socket head
18	14-7008		Screw—housing to clutch cover ($\frac{1}{8}$ " U.N.C. $1\frac{1}{2}$ " U.H.)	1	Socket head
19	14-7018		Screw—housing to adaptor ($\frac{5}{16}$ " U.N.C. $\frac{1}{2}$ " U.H.)	1	Socket head
20	21-0582		Stud—housing to adaptor ($\frac{5}{16}$ " U.N.F./U.N.C. $1\frac{1}{2}$ ")	2	
21	14-1302		Nut—housing stud	2	
22	60-2330		Washer—housing stud nut (.333"—.625"—.040")	2	
23	60-4212	17576849	Solenoid	1	
24	60-4592	54190044	Lucar terminal, solenoid	1	
25	71-3665		Sleeve nut—solenoid stud	1	
26	57-0825		Washer—sleevenut (.328"—.562"—.062")	1	
27	71-3664	54132066	Nut—solenoid stud (M6—6H .160" thick)	1	
28	70-2728	185068	Washer—solenoid stud nut (.266"—.406"—.036")	1	
29	71-3663		Pivot pin—drive assembly	1	
30	82-8981		Washer for pivot pin (.328"—.500"—.048")	1	
31	71-3655	54246003	Intermediate shaft assembly	1	
32	71-3661		Thrust washer—intermediate gear	1	
33	71-3662		Circlip—thrust washer	1	
34	83-5529		Starter motor cover	1	
35	83-5583		Rubber pad—starter cover	1	
36	—	54246123	Drive assembly (includes thrust collar and jump ring for intermediate shaft)	1	
37	—	54247153	Lever assembly	1	
38	—	54245340	Spring, spacing, and sundry parts.	1	

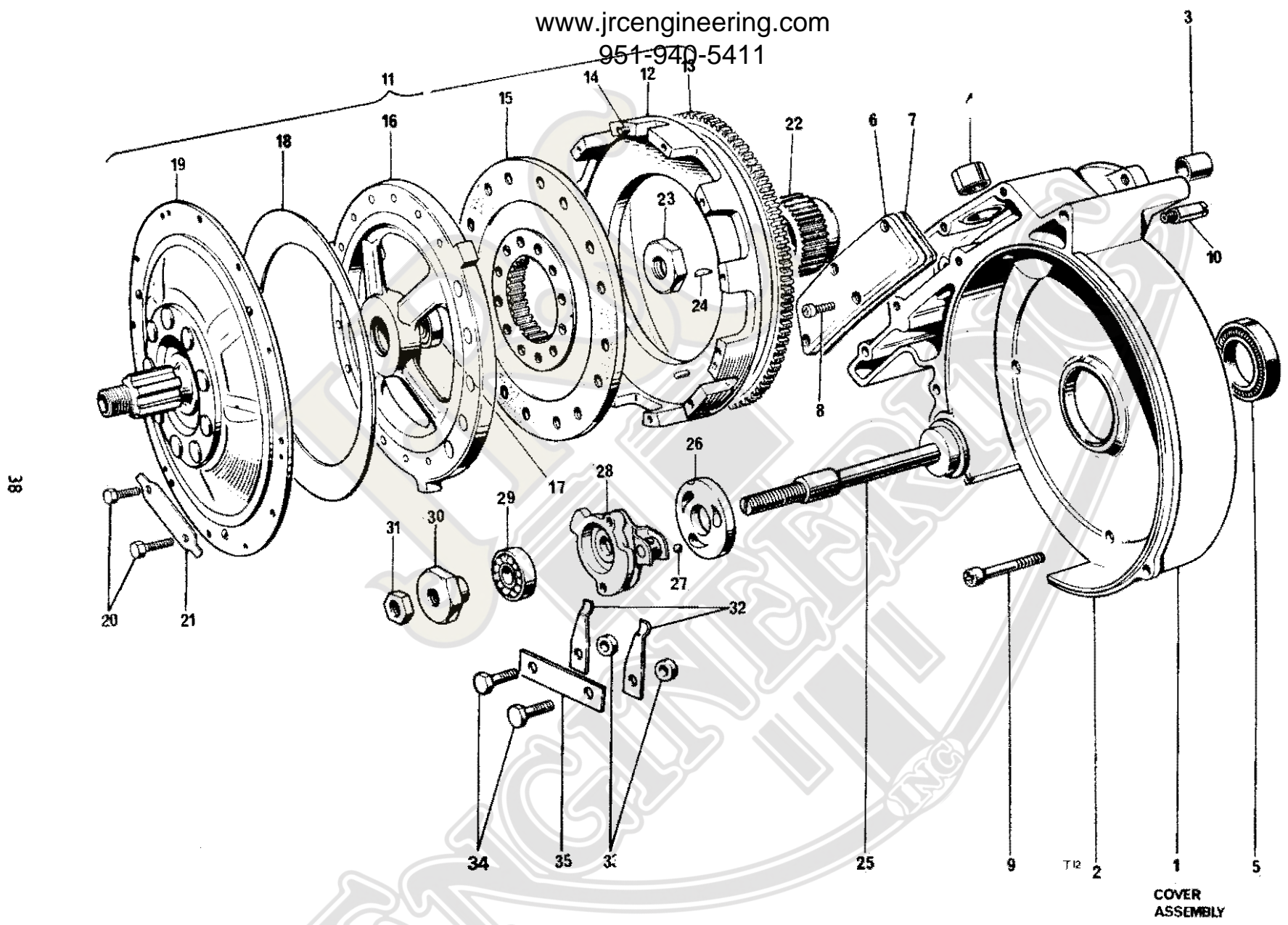

Fig. 13. CLUTCH AND CLUTCH OPERATING MECHANISM

Ref. No.	Triumph Part No.	Makers Part No.	DESCRIPTION	QUANTITY	REMARKS
CLUTCH AND CLUTCH OPERATING MECHANISM					
1	57-4673		Clutch cover—assembled	1	
2	57-4667		Clutch cover only... ..	1	
3	57-4674		Bush—starter shaft	1	
4	57-4876		Breather tube	1	
5	57-3642		Oil seal—clutch cover	1	
6	57-4874		Cover—breather duct	1	
7	57-4875		Gasket—duct cover	1	
8	14-6606		Screw—duct cover to crankcase ($\frac{1}{4}$ " U.N.C. \times $\frac{3}{4}$ " U.H.)	4	
9	14-6610		Screw—clutch cover to crankcase ($\frac{1}{4}$ " U.N.C. \times $1\frac{1}{2}$ " U.H.)	3	
10	57-3756		Adaptor—oil tank breather	1	
11	57-4675		Clutch assembly	1	
12	57-4677		Drive ring	1	
13	57-4678		Ring gear—drive ring	1	
14	57-3730	76186	Dowel—drive ring	3	
15	57-3709	53273	Driven plate assembly	1	
16	57-3715	76185	Pressure plate assembly	1	
17	57-3717	76168	Thrust bearing—pressure plate	1	
18	57-3718	75303/13	Spring—diaphragm (red)	1	
19	57-3705	76169	End cover assembly	1	
20	57-3719	K26904	Bolt—end cover to housing	12	
21	57-3720	76170	Tab washer, for bolt	6	
22	57-2580		Clutch hub	1	
23	21-0681		Nut—hub to mainshaft	1	
24	60-4253		Key—hub to mainshaft	1	
25	57-2552		Pull rod—clutch release	1	
26	57-2465		Thrust plate—inner	1	
27	60-2364		Ball— $\frac{1}{4}$ " diameter	3	
28	57-4933		Clutch operating lever	1	
29	57-3647		Bearing—outer thrust plate	1	
30	57-2553		Sleeve nut	1	
31	14-0402		Locknut ($\frac{5}{16}$ " U.N.F.)	1	
32	57-2473		Spring—outer thrust plate	2	
33	57-3638		Distance piece—spring	2	
34	14-6102		Bolt—spring ($\frac{1}{4}$ " U.N.C. \times $\frac{5}{8}$ " U.H.)	2	
35	57-4916		Tab washer, for bolt	1	

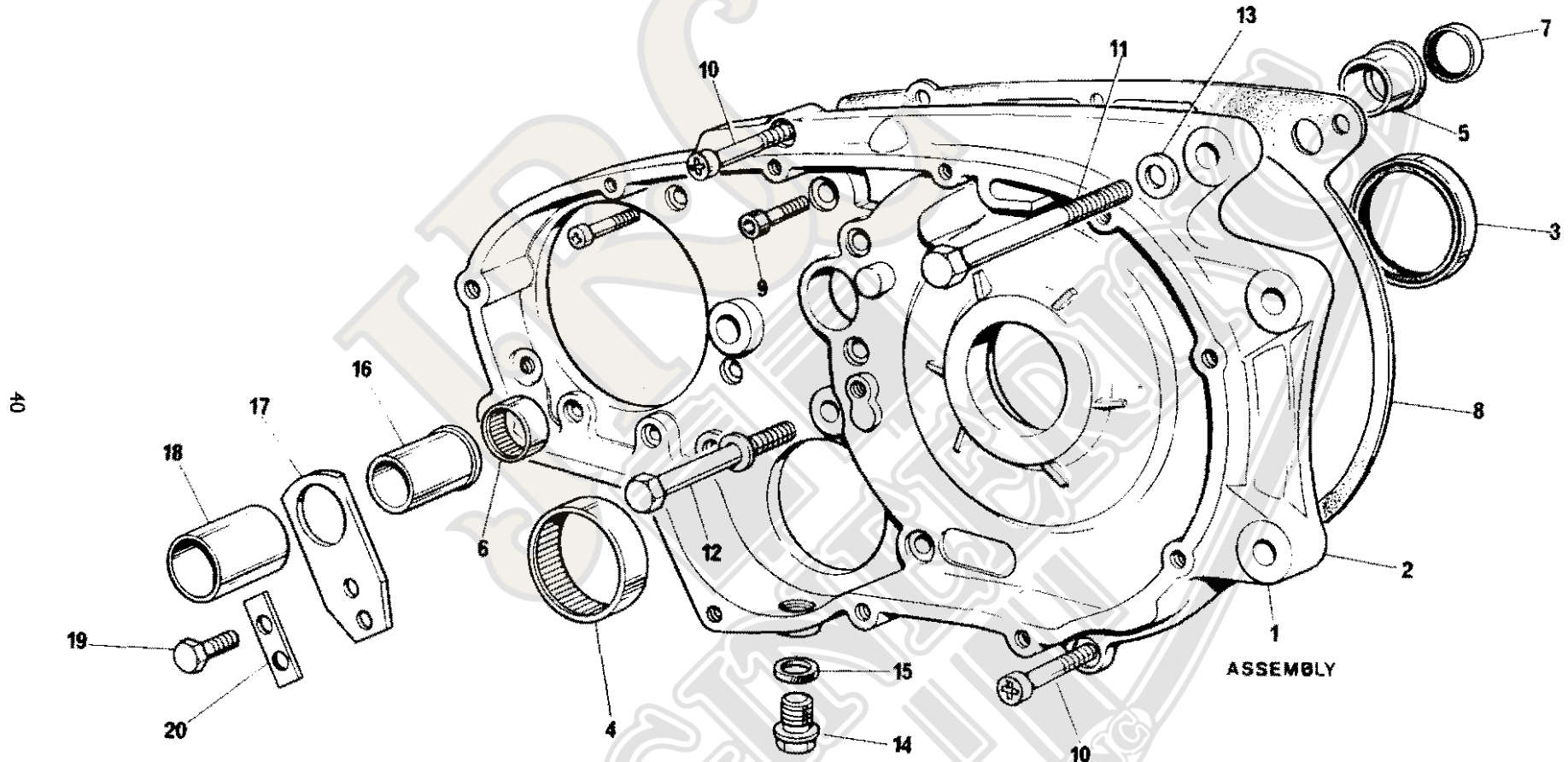

Fig. 14. INNER PRIMARY CHAINCASE

Ref. No. Part No. DESCRIPTION QUANTITY REMARKS

INNER PRIMARY CHAINCASE

1	57-5118	Inner Primary Chaincase, assembled	1	
2	57-5119	Inner Primary chaincase only	1	
3	57-3642	Oil seal—clutch shaft	1	
4	57-3643	Bearing—needle roller	1	
5	57-4932	Bearing housing—cross shaft	1	
6	60-4333	Bearing—needle roller, cross shaft	1	
7	60-4504	Oil seal—cross shaft	1	
8	71-3987	Gasket—inner chaincase to crankcase	1	
9	14-7006	Screw—inner chaincase to crankcase ($\frac{1}{4}$ " U.N.C. \times 1" U.H.)	7	Socket head
10	14-6606	Screw—inner chaincase to crankcase ($\frac{1}{4}$ " U.N.C. \times $\frac{3}{4}$ " U.H.)	2	
11	21-1820	Bolt—inner chaincase to crankcase ($\frac{5}{16}$ " U.N.C. \times $4\frac{1}{2}$ " U.H.)	1	
12	21-1819	Bolt—inner chaincase to crankcase ($\frac{5}{16}$ " U.N.C. \times $4\frac{1}{2}$ " U.H.)	1	
13	60-4247	Washer, for bolts ($.312$ " \times $.625$ " \times $.062$ ")	2	
14	21-0536	Drain plug	1	
15	70-0402	Washer, for drain plug ($.375$ "— $.562$ "— $.062$ ") Fiber	1	
16	57-4927	Locating sleeve—gearshift cross shaft	1	
17	57-4928	Locating plate—gearshift cross shaft	1	
18	57-4930	Spacer—gearshift cross shaft	1	
19	14-6101	Screw—locating plate to chaincase ($\frac{1}{4}$ " U.N.C. \times $\frac{1}{2}$ " U.H.)	2	
20	57-4929	Washer (tab), for screws	1	

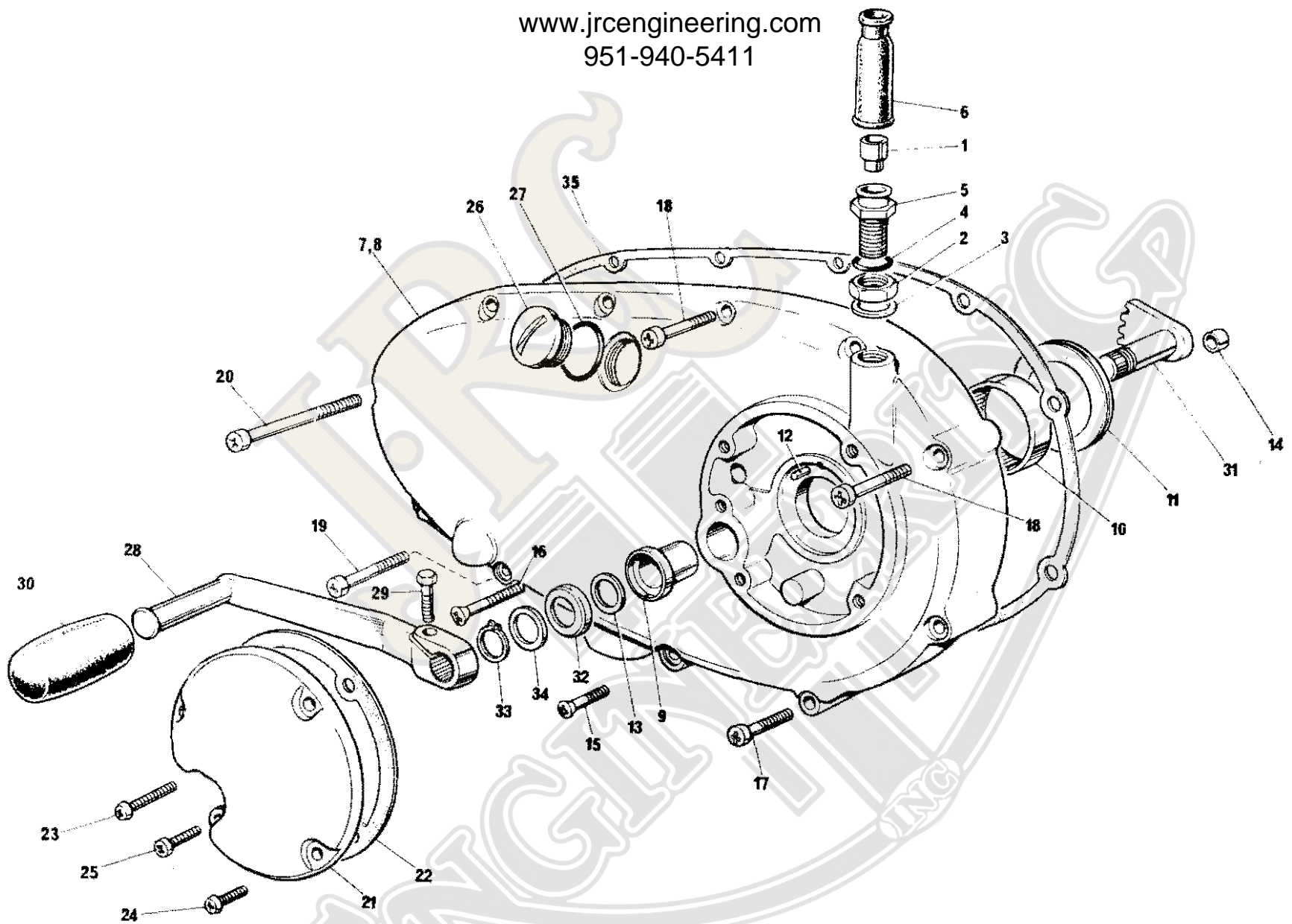

Fig. 15. OUTER PRIMARY CHAINCASE

Ref. No. Part No. DESCRIPTION QUANTITY REMARKS

OUTER PRIMARY CHAINCASE

Ref. No.	Part No.	DESCRIPTION	QUANTITY	REMARKS
1	57-1645	Adaptor—clutch cable	1	
2	21-0567	Locknut—adaptor	1	
3	57-3990	Washer, for locknut	1	
4	57-3733	Sealing ring—adaptor	1	
5	57-2220	Abutment—cable	1	
6	57-1646	Rubber cap—adaptor	1	
7	57-5120	Outer primary chaincase, assembled	1	
8	57-5121	Outer chaincase only	1	
9	57-4978	Bush—gearshift spindle...	1	
10	57-3643	Bearing—clutch shaft	1	
11	57-2215	Thrust washer	1	
12	57-0912	Peg—thrust washer	1	
13	60-4442	Oil seal—gearshift pedal spindle	1	
14	57-0989	Dowel—outer/inner chaincase	2	
15	14-6504	Screw—outer/inner chaincase ($\frac{1}{4}$ " U.N.C. \times $\frac{3}{4}$ " U.H.)	2	c' sunk head
16	14-6509	Screw—outer/inner chaincase ($\frac{1}{4}$ " U.N.C. \times $1\frac{3}{4}$ " U.H.)	1	c' sunk head
17	14-6610	Screw—outer/inner chaincase ($\frac{1}{4}$ " U.N.C. \times $1\frac{1}{2}$ " U.H.)	1	
18	14-6611	Screw—outer/inner chaincase ($\frac{1}{4}$ " U.N.C. \times $1\frac{3}{4}$ " U.H.)	6	
19	14-6612	Screw—outer/inner chaincase ($\frac{1}{4}$ " U.N.C. \times 2" U.H.)	1	
20	14-6615	Screw—outer chaincase to crankcase ($\frac{1}{4}$ " U.N.C. \times 3" U.H.)	1	
21	57-4911	Inspection cover	1	
22	57-4913	Gasket—inspection cover	1	
23	14-7806	Screw—inspection cover ($\frac{1}{4}$ " U.N.C. \times $\frac{3}{4}$ " U.H.)	1	
24	14-7805	Screw—inspection cover ($\frac{1}{4}$ " U.N.C. \times $\frac{5}{8}$ " U.H.)	4	
25	14-6605	Screw—inspection cover ($\frac{1}{4}$ " U.N.C. \times $\frac{5}{8}$ " U.H.)	1	
26	57-2166	Filler plug	1	
27	70-8782	'O' ring—filler plug	1	
28	57-3757	Gearshift pedal	1	
29	14-0201	Pinch bolt—gearshift pedal ($\frac{1}{4}$ " U.N.F. \times 1" U.H.)	1	
30	57-2450	Rubber—gearshift pedal	1	
31	57-4923	Gearshift pedal spindle	1	
32	57-4979	Dust cover—gearshift pedal spindle	1	
33	60-4447	Circlip—gearshift pedal spindle	1	
34	57-1962	Washer (.752"—1.125"—.064")	1	
35	71-1454	Gasket—outer/inner chaincase	0	

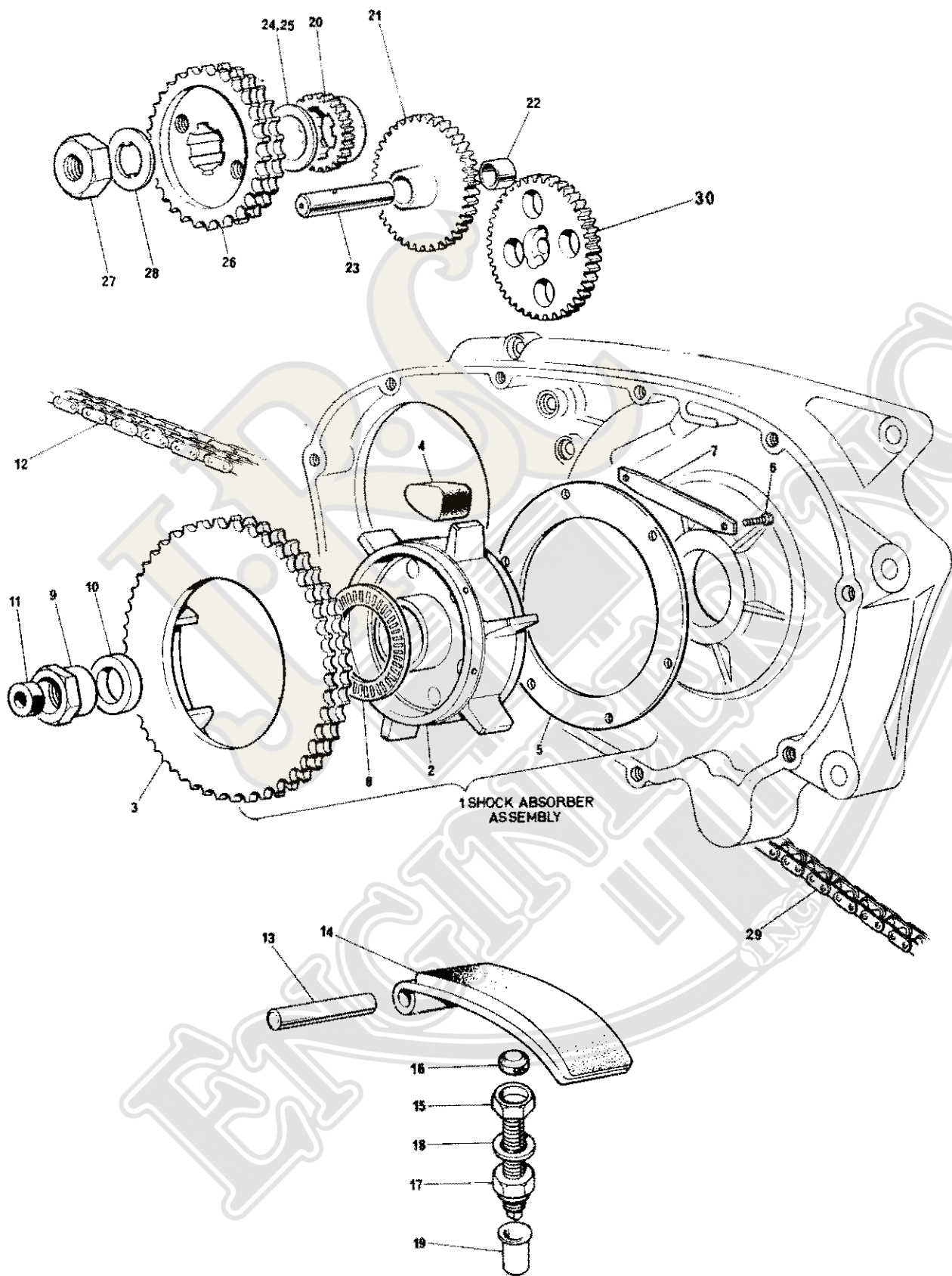

Fig. 16. PRIMARY SHOCK ABSORBER AND OIL PUMP DRIVE

Ref. No. Part No. DESCRIPTION QUANTITY REMARKS

PRIMARY SHOCK ABSORBER AND OIL PUMP DRIVE

Ref. No.	Part No.	DESCRIPTION	QUANTITY	REMARKS
1	57-4895	Shock absorber assembly	1	
2	57-4917	Spider—shock absorber	1	
3	57-4920	Sprocket (43 Teeth)	1	
4	57-5001	Rubber—shock absorber	12	
5	57-4004	Plate—retaining	1	
6	57-3940	Bolt—retaining plate	6	
7	57-3941	Washer (tab)—retaining plate bolt	3	
8	57-3646	Thrust race—spider	1	
9	57-2480	Nut—mainshaft	1	
10	57-2478	Spacer—mainshaft nut	1	
11	57-3644	Oil seal—pull rod	1	
12	60-4307	Primary chain—70 links	1	
13	57-4596	Pivot pin—chain tensioner	1	
14	57-4937	Tensioner blade—primary chain	1	
15	71-4251	Screw—chain adjustment	1	
16	71-3221	Pad—adjustment screw	1	
17	14-1904	Nut—adjustment screw	1	
18	71-3222	Washer, sealing—adjustment screw	1	
19	71-4252	Cover—adjustment screw	1	
20	70-7248	Driving gear—oil pump	1	
21	70-7246	Intermediate gear—oil pump drive	1	
22	70-6885	Bush—intermediate gear	1	
23	71-1051	Spindle—intermediate gear	1	
24	70-8038	Shim—engine sprocket (.010" thick)	1	as required
25	71-2660	Shim—engine sprocket (.030" thick)		
26	71-3541	Sprocket—engine (23 teeth)	1	
27	21-0585	Nut—engine sprocket	1	
28	70-8785	Washer (tab)—sprocket nut	1	
29	60-3297	Rear chain—110 links	1	
30	71-4237	Driven gear—oil pump (also appears on Page 19)	1	

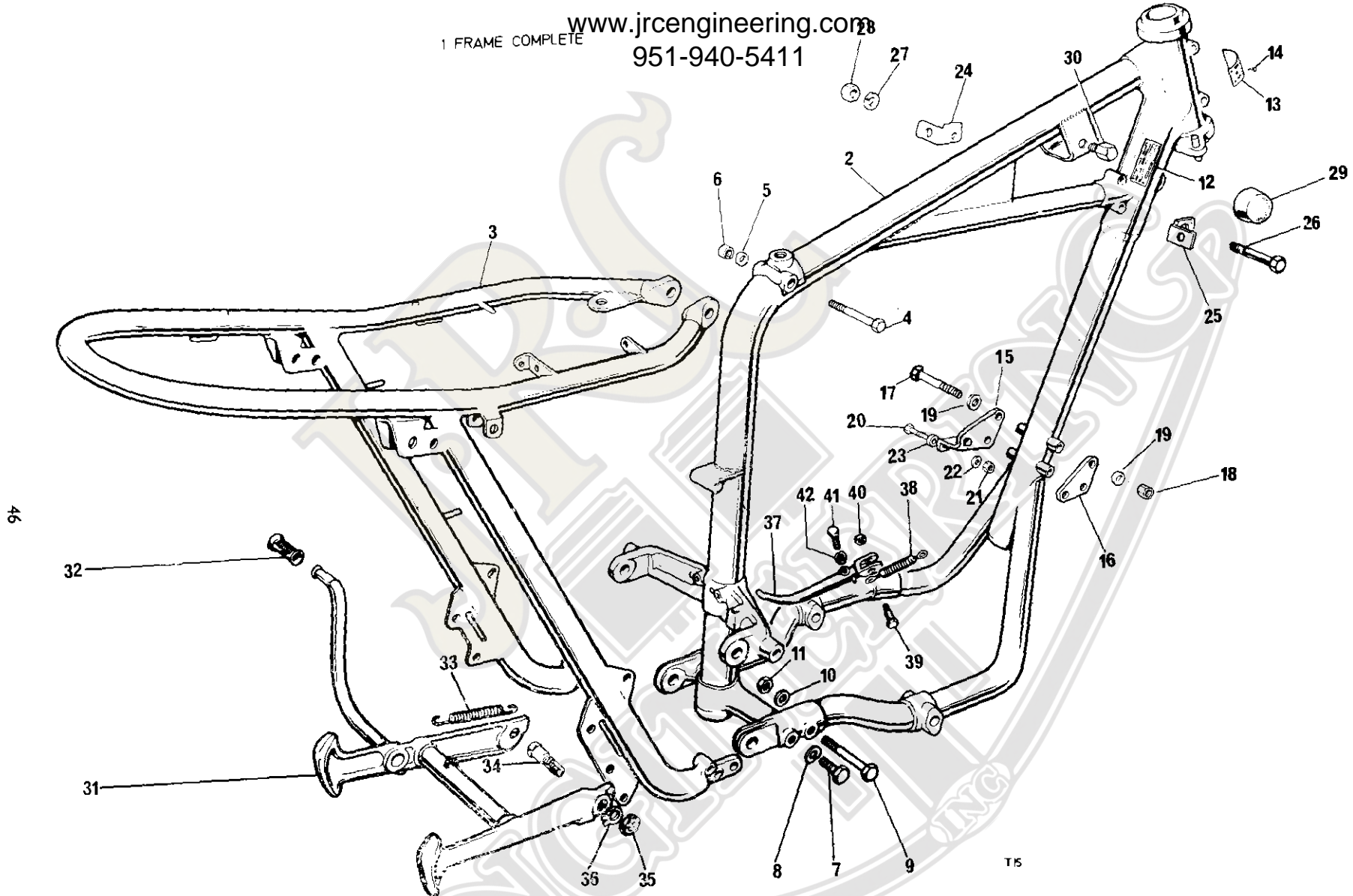

Fig. 17. FRAME

Ref. No.	Part No.	DESCRIPTION	QUANTITY	REMARK
FRAME				
1	83-5897	Frame—assembly	1	
2	83-5898	Frame—front section	1	
3	83-5813	Frame—rear section	1	
4	14-0241	Bolt, top—rear frame to front frame ($\frac{3}{8}$ " U.N.F. \times $3\frac{1}{2}$ " U.H.) ...	1	
5	60-4246	Washer—top frame bolt (.375"—.750"—.064")	1	
6	14-1303	Nut—top frame bolt ($\frac{3}{8}$ " U.N.F. self-locking)	1	
7	21-0588	Bolt, bottom rear—rear frame to front frame ($\frac{7}{16}$ " U.N.F. \times $1\frac{3}{8}$ " U.H.)	2	
8	60-4251	Washer, spring—bottom rear bolt (.531"—.739"—.104")	2	
9	14-0251	Bolt, bottom front—rear frame to front frame ($\frac{7}{16}$ " U.N.F. \times $2\frac{3}{4}$ " U.H.)	2	
10	60-2323	Washer—bottom front bolt (.458"—.875"—.092")	2	
11	14-1304	Nut—bottom front bolt ($\frac{7}{16}$ " U.N.F., self-locking)	2	
12	60-4520	Identification label	1	N. America only;
13	60-4594	Identification label	1	Except N. Amer
14	06-1287	Screw, hammer drive—identification label	4	Except N. Amer
15	83-5899	Engine plate—front, L.H.	1	
16	83-5900	Engine plate—front, R.H.	1	
17	14-0242	Bolt—engine plate to frame ($\frac{3}{8}$ " U.N.F. \times 4 U.H.)	2	
18	14-1303	Nut—engine plate bolt ($\frac{3}{8}$ " U.N.F., self-locking)	2	
19	60-2322	Washer—engine plate bolt (.395"—.750"—.072")	4	
20	14-0106	Bolt—horn to engine mounting bracket L.H. ($\frac{1}{4}$ " U.N.F. \times $1\frac{1}{4}$ " U.H.)	2	
21	14-1901	Nut—horn mounting bolt ($\frac{1}{4}$ " U.N.F., self-locking)	2	
22	60-2320	Washer—horn mounting bolt (.270"—.562"—.056")	4	
23	70-3448	Spacer—horn fixing	2	
24	83-5423	Bracket—oil cooler, L.H.	1	
25	83-5424	Bracket—oil cooler, R.H.	1	
26	21-1805	Bolt—oil cooler bracket ($\frac{5}{16}$ " U.N.F. \times $2\frac{1}{8}$ " U.H.)	1	
27	60-2418	Washer, spring—bracket bolt	1	
28	14-0402	Nut—bracket bolt ($\frac{5}{16}$ " U.N.F., self-locking)	1	
29	83-5353	Rubber—gas tank mounting	2	
30	21-2300	Bolt—gas tank mounting rubber	2	
31	83-1267	Center stand	1	
32	57-2331	Rubber—center stand arm	1	
33	82-4671	Spring—center stand	1	
34	21-1978	Pivot bolt—center stand	2	
35	14-0404	Nut—pivot bolt ($\frac{2}{16}$ " U.N.F.)	2	
36	83-1270	Washer (tab)—pivot bolt	2	
37	83-5857	Side stand	1	
38	82-8382	Spring—side stand	1	
39	82-7021	Swivel pin—side stand	1	
40	14-0703	Nut—swivel pin ($\frac{3}{8}$ " U.N.F., self-locking)	1	
41	14-0113	Bolt, stop—side stand ($\frac{5}{16}$ " U.N.F. \times $\frac{5}{8}$ " U.H.)	1	
42	14-0402	Nut—side stand stop bolt ($\frac{5}{16}$ " U.N.F.)	1	

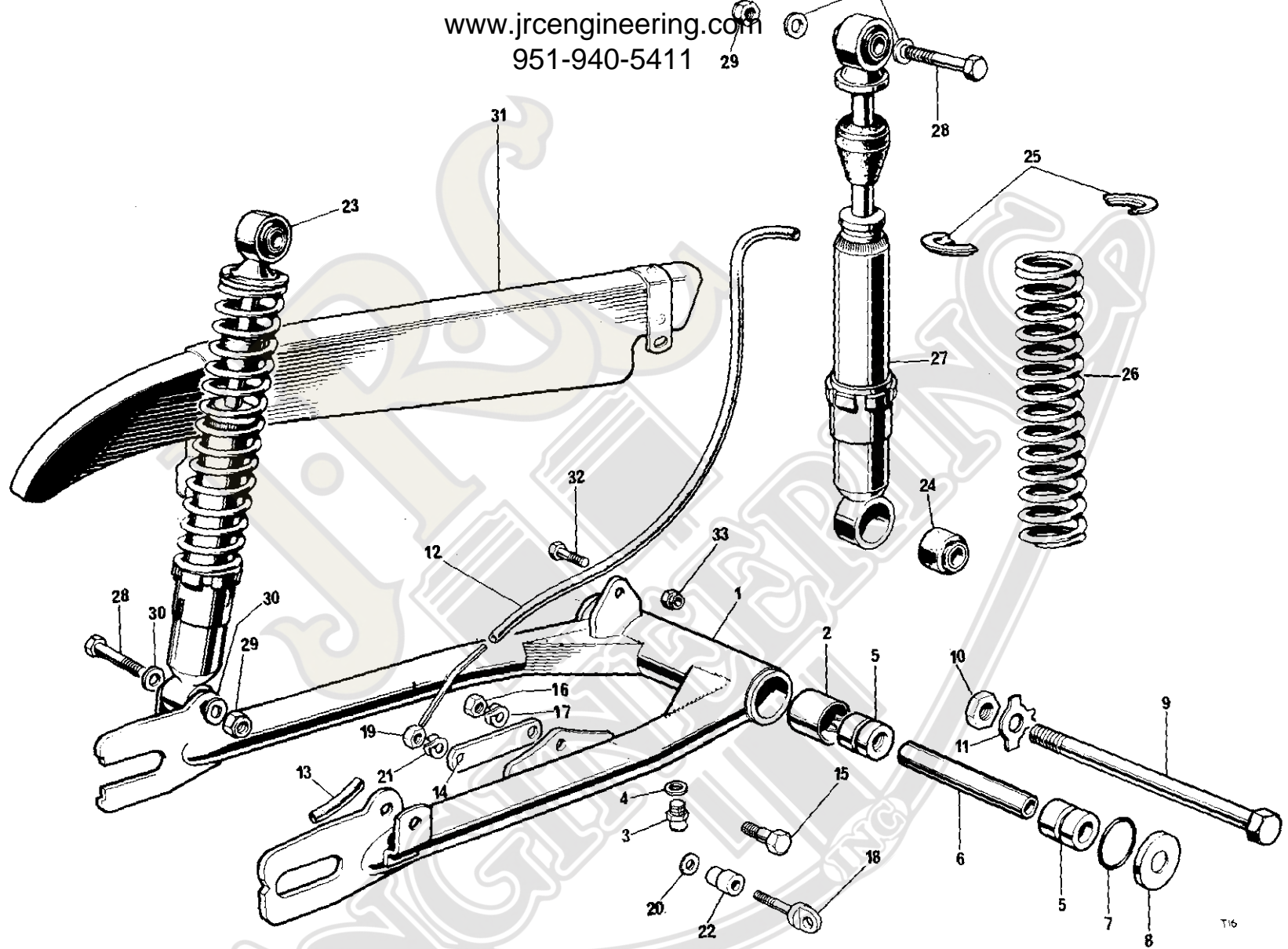

Fig. 18. SWINGING FORK AND SUSPENSION UNIT

Ref. No.	Triumph Part No.	Makers Part No.	DESCRIPTION	QUANTITY	REMARKS
----------	------------------	-----------------	-------------	----------	---------

SWINGING FORK AND SUSPENSION UNIT

1	83-5368		Swinging Fork	1	
2	82-6042		Bush—swinging fork	2	
3	60-1841		Grease nipple	1	
4	71-2501		Washer—grease nipple (.297"—500"—078"), fiber	1	
5	82-6821		Bobbin, L.H. and R.H.	2	
6	82-5313		Distance tube—bobbins	1	
7	82-8090		'O' ring—swinging fork seal	2	
8	82-7848		Housing—'O' ring	2	
9	21-0602		Bolt—swinging fork pivot ($\frac{9}{16}$ " U.N.F. \times $8\frac{5}{8}$ " U.H.)	1	
10	21-0545		Nut—pivot bolt ($\frac{9}{16}$ " U.N.C.)	1	
11	82-5944		Washer (tab)—pivot bolt	1	
12	82-7352		Chain oiler pipe, rear—long	1	
13	82-9997		Chain oiler pipe, rear—short	1	
14	83-5231		Torque arm—rear brake	1	
15	83-5549		Bolt—torque arm to swinging fork	1	
16	14-1302		Nut—torque arm bolt ($\frac{5}{16}$ " U.N.F., self-locking) ...	1	
17	60-2440		Washer, double coil spring—torque arm bolt ...	1	
18	21-2244		Eye bolt—torque arm to brake anchor plate ...	1	
19	14-1302		Nut—eye bolt ($\frac{5}{16}$ " U.N.F., self-locking)	1	
20	60-2339		Washer—eye bolt (.333"—.750"—.072")	1	
21	60-2440		Washer, double coil spring—eye bolt	1	
22	83-5550		Distance piece—eye bolt	1	
23	60-2294	64052341	Suspension Unit complete	2	
24	99-0122	640533645	Bonded bush	4	
25	99-0107	9054/171	Spring retainer	4	
26	99-1139	64544754	Spring (110 lbs)	2	
27		64052090	Damper unit	2	
28	14-0235		Bolt, top and bottom—suspension unit ($\frac{3}{8}$ " U.N.F. \times 2" U.H.)	4	
29	14-1303		Nut—suspension unit bolts ($\frac{3}{8}$ " U.N.F., self-locking)	4	
30	60-4246		Washer-suspension unit bolts (.375"—.750"—.064")	8	
31	83-5237		Rear chainguard	1	
32	14-2220		Bolt, front-pivot ($\frac{5}{16}$ " U.N.F. \times $\frac{5}{8}$ " U.H.)	1	
33	14-0702		Nut—pivot bolt ($\frac{5}{16}$ " U.N.F., self-locking)	1	

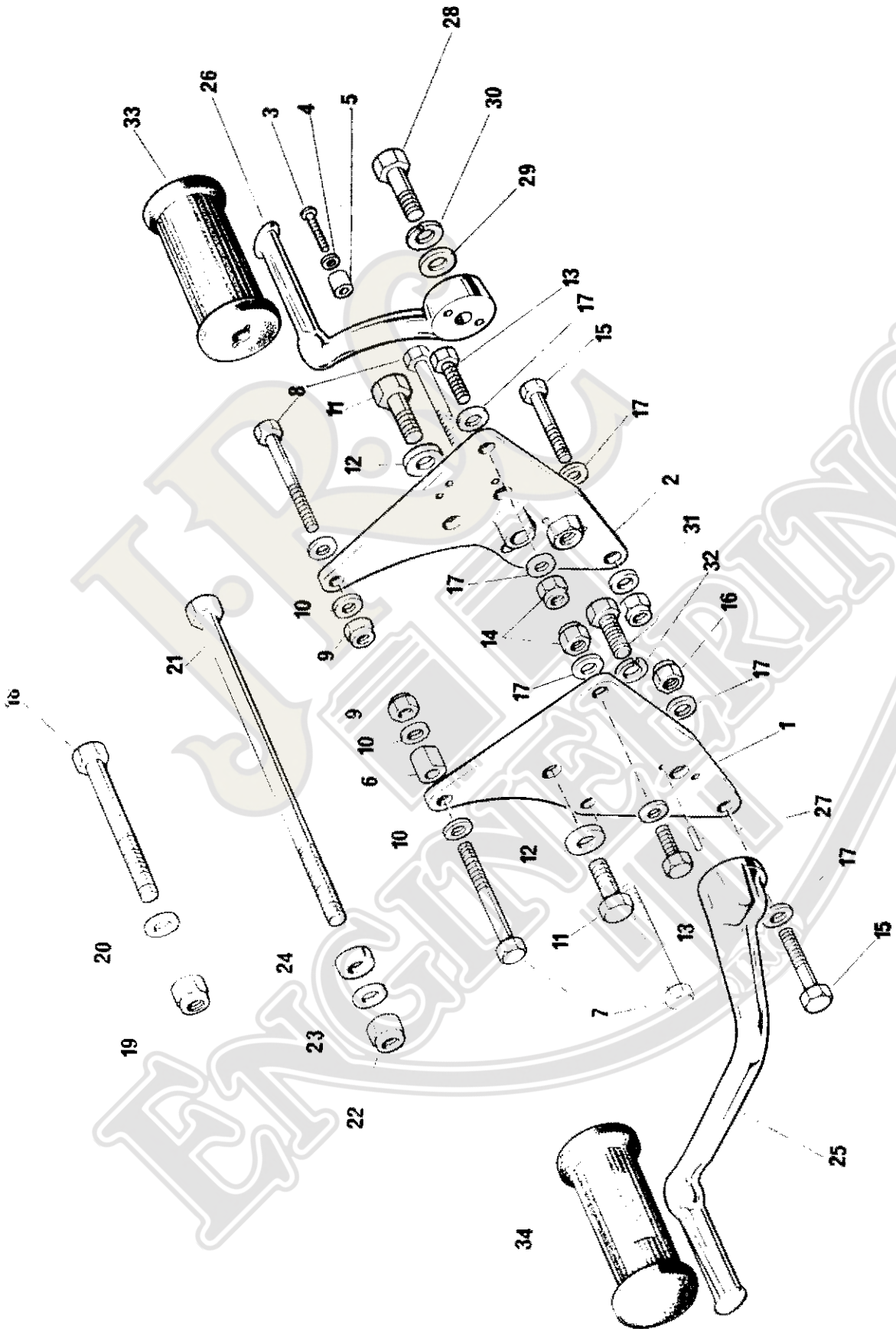

FIG. 19. ENGINE UNIT FITTINGS AND FOOTPEGS

Ref. No.	Part No.	DESCRIPTION	QUANTITY	REMARKS
ENGINE UNIT FITTINGS AND FOOTPEGS				
1	83-5270	Engine plate, rear—left side	1	
2	83-5473	Engine plate, rear—right side	1	
3	83-5388	Screw—stoplite switch to engine plate	2	"Taptite"
4	70-2351	Washer—switch screw (.265"—.375"—.036")	2	
5	83-5548	Distance piece—stop lite switch	2	
6	83-1598	Spacer—rear engine plate L.H.	2	
7	14-0223	Bolt—rear engine plate to engine, L.H. ($\frac{5}{16}$ " U.N.F. \times 2 $\frac{1}{2}$ " U.H.)	2	
8	14-0221	Bolt—rear engine plate to engine R.H. ($\frac{5}{16}$ " U.N.F. \times 2" U.H.)	2	
9	14-1302	Nut—rear engine plate bolts ($\frac{5}{16}$ " U.N.F., self-locking)	4	
10	60-4247	Washers—rear engine plate bolts and nuts (.343"—.625"—.062")	8	
11	14-0132	Bolt—rear engine plate (L.H.) to pivot lug ($\frac{7}{16}$ " U.N.F. \times $\frac{7}{8}$ " U.H.)	2	
12	60-2323	Washer—pivot lug bolt (.458"—.875"—.092")	2	
13	14-0128	Bolt—rear engine plate (R.H.) to engine, upper rear, ($\frac{3}{8}$ " U.N.F. \times 1" U.H.)	2	
14	14-1303	Nut—upper rear engine plate bolt ($\frac{3}{8}$ " U.N.F., self-locking)	2	
15	14-0234	Bolt—rear engine plate (L.H. and R.H.) to frame, lower ($\frac{3}{8}$ " U.N.F. \times 1 $\frac{3}{4}$ " U.H.)	2	
16	14-1303	Nut—lower rear engine plate bolt ($\frac{3}{8}$ " U.N.F., self-locking)	2	
17	60-4246	Washer—lower rear engine plate bolt (.375"—.750"—.064")	6	
18	14-0255	Bolt, front—engine to frame ($\frac{7}{16}$ " U.N.F. \times 4" U.H.)	1	
19	14-1304	Nut—engine to frame bolt ($\frac{7}{16}$ " U.N.F., self-locking)	1	
20	60-2323	Washer—engine to frame bolt (.458"—.875"—.092")	2	
21	21-2112	Bolt, bottom—engine to frame ($\frac{7}{16}$ " U.N.F. \times 10-06" U.H.)	1	
22	14-1304	Nut—engine to frame bolt ($\frac{7}{16}$ " U.N.F., self-locking)	1	
23	60-2332	Washer—engine to frame bolt (.458"—.875"—.048")	1	
24	83-5845	Spacer—bottom engine fixing	1	
25	83-5581	Footpeg, left	1	
26	83-5477	Footpeg, right	1	
27	82-5943	Peg—footpegs	4	
28	14-0246	Bolt—footpeg, rightside ($\frac{7}{16}$ " U.N.F. \times 1 $\frac{1}{2}$ " U.H.)	1	
29	60-4267	Washer—footpeg bolt rightside (.453"—.750"—.064")	1	
30	60-2420	Washer, spring—footpeg bolt, right side	1	
31	21-1969	Bolt—footpeg, left side ($\frac{1}{2}$ " U.N.F. \times 1 $\frac{1}{4}$ " U.H.)	1	
32	82-8243	Washer spring—footpeg bolt, left side	1	
33	82-9279	Rubber—footpeg, right	1	
34	82-9630	Rubber—footpeg, left	1	

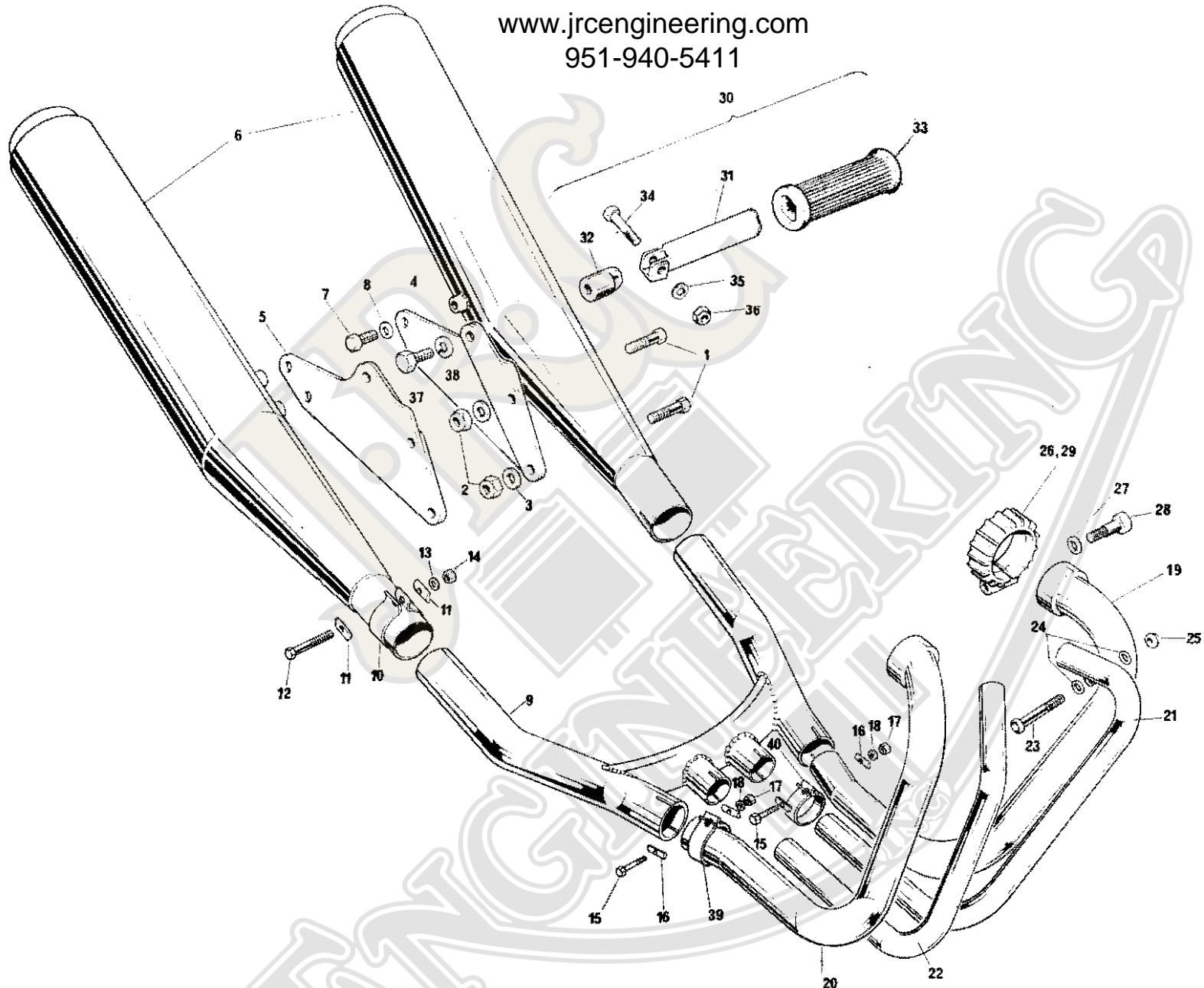

Fig. 20. EXHAUST SYSTEM AND PILLION FOOTPEGS

Ref. No.	Part No.	DESCRIPTION	QUANTITY	REMARKS
EXHAUST SYSTEM AND PILLION FOOTPEGS				
1	14-0116	Bolt—muffler bracket to frame ($\frac{5}{16}$ " U.N.F. \times 1" U.H.) ...	3	
2	14-1302	Nut—muffler bracket bolt ($\frac{5}{16}$ " U.N.F., self-locking) ...	3	
3	60-2330	Washer—muffler bracket bolt ...	6	
4	83-5853	Bracket—pillion footpeg and muffler L.H. ...	1	
5	83-5854	Bracket—pillion footpeg and muffler, R.H. ...	1	
6	71-4402	Muffler ...	2	
7	14-0113	Bolt—bracket to muffler ($\frac{5}{16}$ " U.N.F. \times $\frac{5}{8}$ " U.H.) ...	4	
8	60-4247	Washer, for bolt (.343"—.625"—.062") ...	4	
9	71-4407	Collector box ...	1	
10	70-5874	Clip—muffler to collector box ...	2	
11	70-3768	Washer—'D' section ...	4	
12	14-0219	Bolt—collector box clip ($\frac{5}{16}$ " U.N.F. \times 1 $\frac{1}{2}$ ") ...	2	
13	60-4247	Washer—plain (.343"—.625"—.062") ...	2	
14	14-1202	Nut—clip bolt ($\frac{5}{16}$ " U.N.F., self-locking) ...	2	
15	14-0219	Bolt—collector box to exhaust pipes ($\frac{5}{16}$ " U.N.F. \times 1 $\frac{1}{2}$ ") ...	4	
16	70-3768	Washer, 'D' section—box/exhaust pipe bolt ...	8	
17	14-1202	Nut—box/exhaust pipe bolt ($\frac{5}{16}$ " U.N.F., self-locking) ...	4	
18	60-4247	Washer,—plain (.343"—.625"—.062") ...	4	
19	71-4424	Exhaust pipe—outer, L.H. ...	1	
20	71-4427	Exhaust pipe—outer, R.H. ...	1	
21	71-4429	Exhaust pipe—inner, L.H. ...	1	
22	71-4431	Exhaust pipe—inner, R.H. ...	1	
23	21-2336	Stud—inner exhaust pipes tie ($\frac{1}{4}$ " U.N.F. \times 4.45" U.H.) ...	1	
24	70-2728	Washer—exhaust pipes tie stud (.265"—.406"—.036") ...	2	
25	14-1201	Nut—exhaust pipes tie stud ($\frac{1}{4}$ " U.N.F., self-locking) ...	1	
26	70-6743	Finned clip—exhaust pipe, L.H. ...	1	
27	70-8860	Washer, spherical—finned clip ...	2	
28	70-6744	Bolt—finned clip ($\frac{5}{16}$ " U.N.F. \times 1 $\frac{3}{16}$ " U.H.) ...	2	
29	71-4459	Finned clip—exhaust pipe, R.H. ...	1	
30	83-5895	Pillion footpeg—assembly ...	2	
31	82-9053	Footpeg—pillion ...	2	
32	83-5896	Anchor—pillion footpeg ...	2	
33	82-9054	Rubber—pillion footpeg ...	2	
34	14-0217	Pivot bolt—pillion footpeg ($\frac{5}{16}$ " U.N.F. \times 1 $\frac{1}{4}$ " U.H.) ...	2	
35	82-9089	Washer—pivot bolt ...	2	
36	14-1302	Nut—pivot bolt ($\frac{5}{16}$ " U.N.F., self-locking) ...	2	
37	14-0128	Bolt—pillion footpeg to bracket ($\frac{3}{8}$ " U.N.F. \times 1" U.H.) ...	2	
38	60-4259	Washer, spring—bracket bolt ...	2	
39	70-7512	Clip, collector box to outer pipes ...	2	
40	71-4458	Clip, collector box to inner pipes ...	2	

Ref. No.	Part No.	DESCRIPTION	QUANTITY	REMARKS
FRONT FORK				
1	97-4605	Front fork assembly	1	
2	97-4566	Bottom yoke (with stem)	1	
3	82-6738	Lock, parking—with keys	1	
4		Key—static serial number	1	
5	21-2315	Grub screw	1	
6	97-2266	Sealing washer—grub screw... ..	1	
7	97-4476	Pinch bolt—bottom yoke	1	
8	14-0237	Pinch bolt—bottom yoke ($\frac{3}{8}$ " U.N.F. \times $2\frac{1}{2}$ " U.H.)	1	
9	14-1303	Nut—pinch bolt ($\frac{3}{8}$ " U.N.F., self-locking)	2	
10	82-2184	Washer—pinch bolt (.380"—.750"—.092")	3	
11	97-4541	Top yoke	1	
12	97-4031	Bearing—taper roller	2	
13	97-4028	Dust cover—bearing, top	1	
14	14-1034	Screw—top yoke ($\frac{3}{8}$ " U.N.F. \times $1\frac{1}{4}$ " U.H.)	2	Socket head
15	14-0234	Pinch bolt—top yoke ($\frac{3}{8}$ " U.N.F. \times $1\frac{3}{4}$ " U.H.)	1	
16	14-1303	Nut—pinch bolt ($\frac{3}{8}$ " U.N.F., self-locking)	1	
17	60-2331	Washer—pinch bolt (.395"—.750"—.048")	1	
18	97-4317	Steering stem nut	1	
19	97-4380	Stanchion	2	
20	97-4387	Top nut—stanchion	2	
21	97-4600	Cap screw—stanchion top nut (with insert)	2	
22	97-4076	End plug—stanchion	2	
23	97-4556	Main spring	2	
24	97-4554	Damper tube assembly	2	
25	97-4010	Damper washer	2	
26	97-4020	Valve	2	
27	97-4003	'O' ring—damper valve	2	
28	97-4244	Nut—damper valve	2	
29	97-4009	Spring—recoil	2	
30	14-1019	Screw—damper tube ($\frac{5}{16}$ " U.N.F. \times $\frac{7}{8}$ " U.H.)	2	Socket head
31	97-4004	Sealing washer—damper tube screw	2	
32	97-4579	Outer member—R.H. (assembly)	1	
33	97-4399	Outer member—L.H. (assembly)	1	
34	97-4545	Outer member—R.H.	1	
35	97-4377	Outer member—L.H.	1	
36	97-4001	Oil seal—outer member	1	
37	21-2102	Stud—outer member ($\frac{5}{16}$ " U.N.C./U.N.F. \times $1\frac{7}{8}$ ")	4	
38	21-2189	Stud—outer member to caliper (L.H.) ($\frac{3}{8}$ " U.N.C./U.N.F. \times $1\frac{1}{2}$ " U.H.)	2	
39	14-0302	Nut—outer member stud ($\frac{5}{16}$ " U.N.F.)	4	
40	60-2428	Washer, spring—outer member stud (.344"—.600"—.064")	4	
41	97-4456	Cap—wheel spindle, L.H.	1	
42	97-4457	Cap—wheel spindle, R.H.	1	
43	82-4715	Drain plug—outer member (2BA $\frac{7}{16}$ " U.H.)	2	
44	97-3893	Washer—drain plug (.187"—.312"—.078") aluminum	2	
45	97-4002	Scraper sleeve—outer member	2	
46	97-4557	Outer cover—L.H.	1	
47	97-4558	Outer cover—R.H.	1	
48	97-5056	Headlite bracket—L.H.	1	
49	97-5057	Headlite bracket—R.H.	1	
50	97-2208	Rubber mounting—headlite bracket	2	
51	97-2209	Rubber buffer—headlite bracket	4	
52	97-2210	Backing washer—headlite bracket	4	
53	21-2095	Attachment bolt—headlite bracket	4	
54	97-4461	Rubber ring	2	
55	60-4595	Identification label	1	Australia only
56	06-1287	Screw—Hammer drive	4	Australia only

2 RIM, SPOKES and HUB ASSY

56

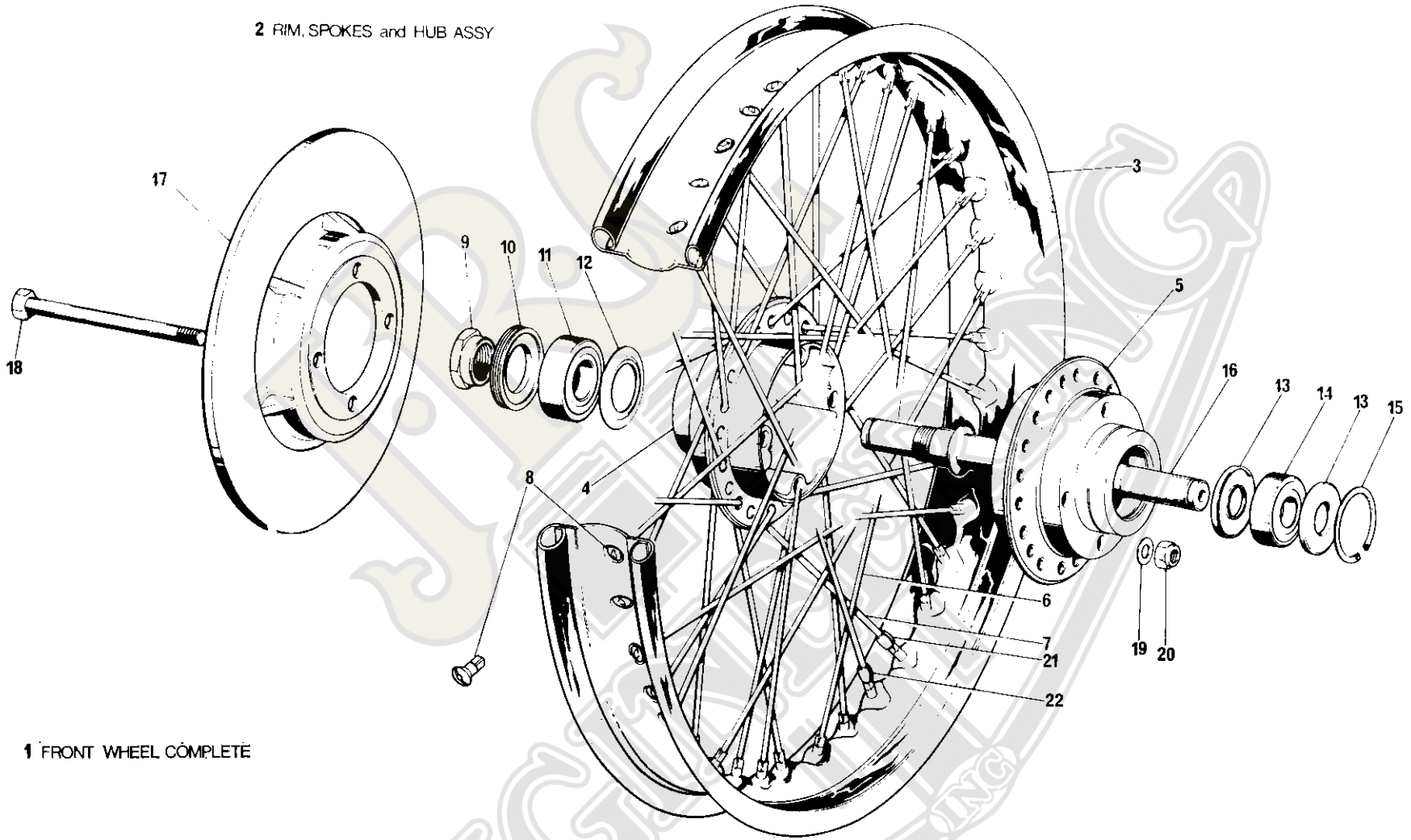

1 FRONT WHEEL COMPLETE

Fig. 22. FRONT WHEEL

T20

Ref. No.	Part No.	DESCRIPTION	QUANTITY	REMARKS
FRONT WHEEL				
1	37-4141	Front wheel—assembly	1	
2	37-4305	Rim, spokes, and hub—assembly	1	
3	37-4129	Rim	1	
4	37-4126	Hub—L.H.	1	
5	37-4127	Hub—R.H.	1	
6	37-4131	Spoke—outer, R.H. and L.H.	20	
7	37-4303	Spoke—inner, R.H. and L.H.	20	
8	37-2294	Nipple—spoke	40	
9	37-4133	Locknut—L.H. bearing	1	
10	37-4134	Lockring—L.H. bearing	1	
11	57-1070	Bearing—L.H.	1	
12	37-4135	Grease retainer—L.H. bearing	1	
13	37-1237	Dust cover—R.H. bearing	2	
14	37-0653	Bearing—R.H.	1	
15	57-0280	Circlip—R.H. bearing	1	
16	37-4132	Spindle	1	
17	37-4275	Disc	1	
18	21-2207	Bolt—disc. to hub ($\frac{3}{8}$ " U.N.F. x 4-56" U.H.)	4	
19	70-8770	Washer—disc. bolt (.390" x .625" x .064")	8	
20	14-1903	Nut—disc. bolt ($\frac{3}{8}$ " U.N.F., self-locking)	4	
21	37-3969	Balance weight—short		As required
22	37-3970	Balance weight—long		As required

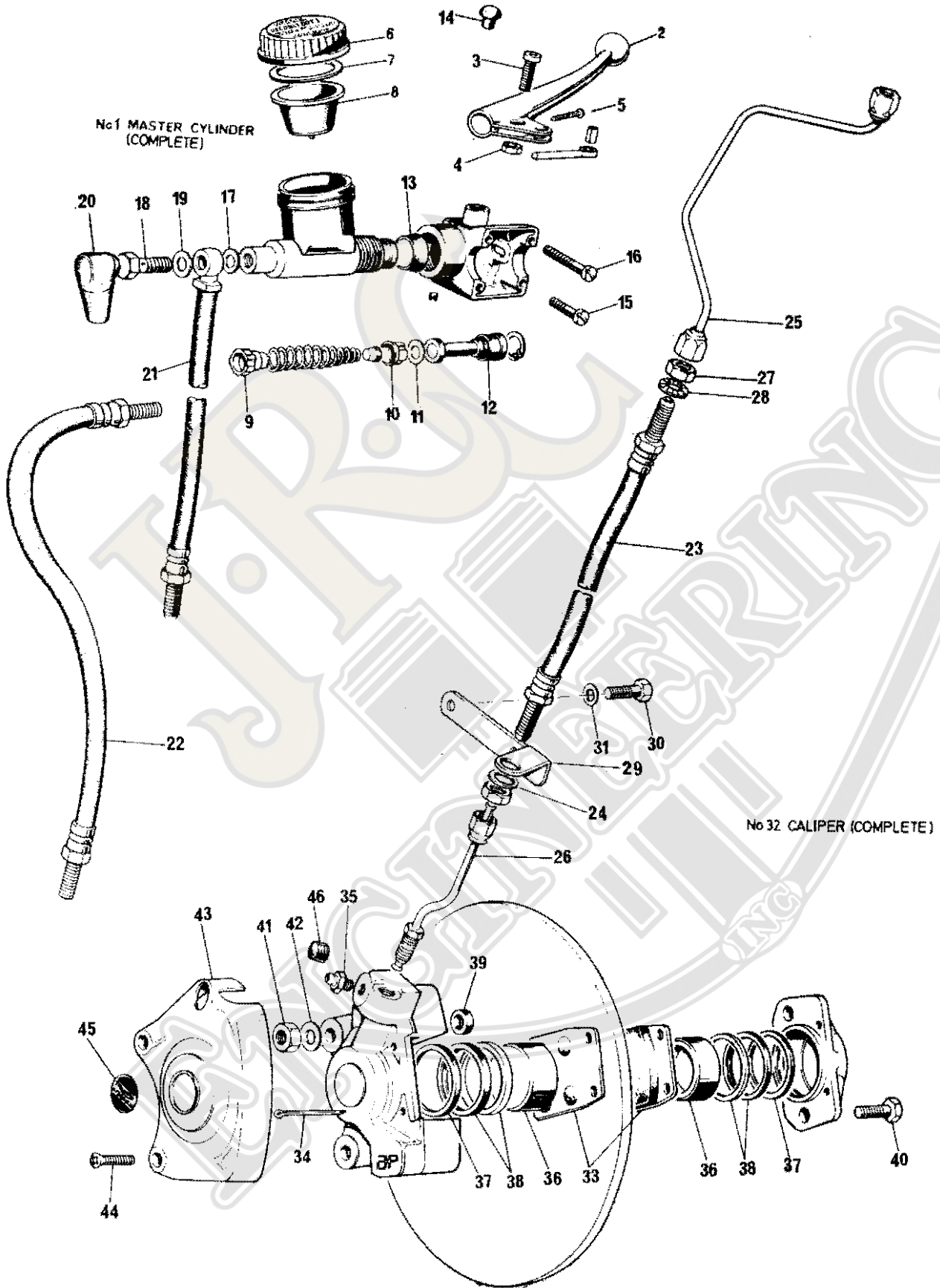

Fig. 23. FRONT BRAKE

Ref. No.	Triumph Part No.	Makers Part No.	DESCRIPTION	QUANTITY	REMARKS
FRONT BRAKE					
1	60-4102	4222-979	Master cylinder	1	
2	97-4391		Brake lever	1	
3	21-2191		Screw—brake lever pivot ($\frac{1}{4}$ " U.N.F. - 1-12 U.H.)	1	
4	14-1201		Nut—pivot screw ($\frac{1}{4}$ " U.N.F., self-locking)	1	
5	21-1998		Screw—stop switch to lever body	1	
6	99-2751	3847—240	Cap	1	
7	60-4328		Washer—cap	1	
8	99-2752	3818—747	*Diaphragm	1	* Available as a s
9	99-2754	4312—318	*Trap valve	1	arate service
10	99-2757	3842—424	*Primary cup	1	No. 99-2768
11	99-2758	106418	*Piston washer	1	
12	99-2760	3871-495	*Secondary	1	
13	99-2762	3811-420	*Rubber boot	1	
14	70-7573		Plug—brake lever	1	
15	21-2192		Screw, short—lever body to switches (No. 10 - 88° U.H.)	2	
16	21-2194		Screw, long—lever body to switches (No. 10 - 1-88 U.H.)	2	
17	60-4182	KL44516	Sealing washer—banjo bolt	1	
18	60-4183	30420	Banjo bolt—master cylinder	1	
19	60-4184	KL44518	Sealing washer—banjo bolt	1	} N. America only
20	60-4186	3817/810	Rubber boot—master cylinder	1	
21	60-4518	KL58504cs	Hose—master cylinder to top yoke	1	
22	60-4177	KL10007cs	Hose—master cylinder to top yoke	1	Except N. Amer
23	60-4175	KL56612cs	Hose—lower yoke to fork bracket	1	
24	97-1708		Washer—hose, lower yoke to fork bracket	1	
25	60-4338	ZT2200N	Pipe—top yoke to bottom yoke (includes nuts)	1	
26	60-4178	ZTA2070N	Pipe—caliper to hose (includes nuts)	1	
27	60-4180	K24103	Locknut	3	
28	70-2288		Lockwasher, for nut	3	
29	97-5055		Bracket—pipe support	1	
30	14-0103		Bolt—bracket to fork ($\frac{1}{4}$ " U.N.F. x $\frac{3}{4}$ " U.H.)	2	} Also appears o page 75.
31	60-2427		Washer—bracket bolt	2	
32	60-4101	4823—432	Caliper	1	} *Service kit available, part No. 99-2769
33		4741—537	† Brake pad		
34		K19866cp	† Retaining pin		
35		28696	Bleed nipple	1	
36	99-2765	3275-428	Piston	2	
37	99-2766	96498	Fluid seal	2	
38	99-2767	SSB72075	Retainer	4	
39		102799	Fluid seal	2	
40		3437-307	Bolt	2	
41	14-1303		Nut, caliper to outer member ($\frac{3}{8}$ " U.N.F. self-locking)	2	
42	60-2331		Washer, for nut (.395"—.750"—.048")	2	
43	37-4263		Cover, caliper	1	
44	21-2335		Screw—cover attachment (No. 6 - 32 U.N.C.)	2	c.sunk head
45	60-4156		Decal—caliper cover	1	
46	60-4266	363400	Cover—bleed nipple	1	

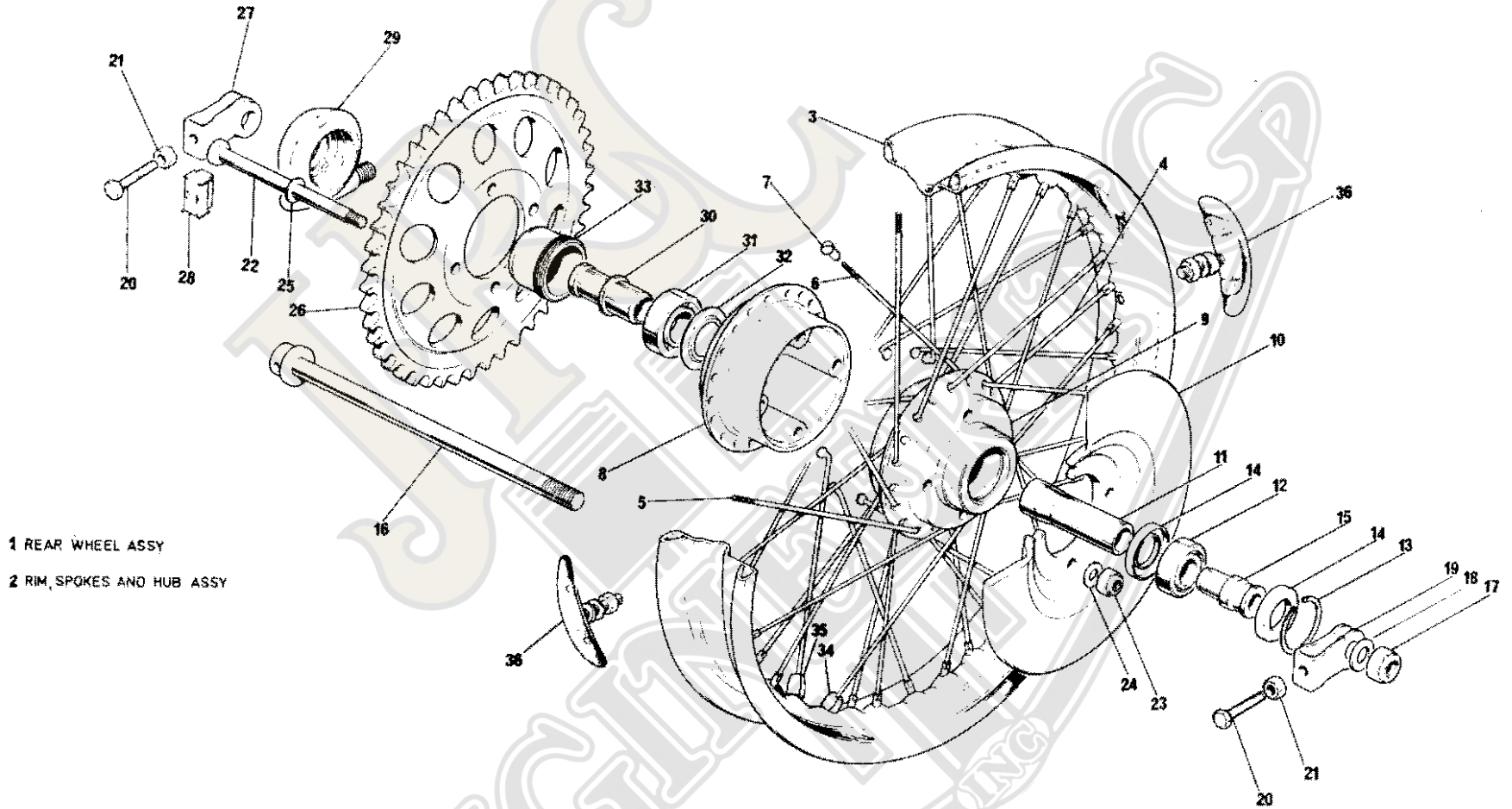

Fig. 24. REAR WHEEL

Ref. No.	Part No.	DESCRIPTION	QUANTITY	REMARKS
REAR WHEEL				
1	37-4252	Rear wheel assembly	1	
2	37-4254	Rim, spokes, and hub assembly	1	
3	37-4243	Rim—W.M.3—19	1	
4	37-4303	Spoke, inner—R.H. and L.H.	20	
5	37-4270	Spoke, outer—R.H.	10	
6	37-4244	Spoke, outer—L.H.	10	
7	37-2294	Nipple	40	
8	37-4206	Hub—L.H. half	1	
9	37-4208	Hub—R.H. half	1	
10	37-4275	Disc	1	
11	37-4214	Inner sleeve	1	
12	37-0653	Bearing—R.H.	1	
13	57-0280	Circlip—R.H. bearing	1	
14	37-4236	Dust cap—R.H. bearing	2	
15	37-4217	Spacer, inner—R.H.	1	
16	37-4261	Spindle	1	
17	14-1307	Nut—wheel spindle ($\frac{5}{8}$ " U.N.F. self-locking)	1	
18	83-2266	Washer—wheel spindle nut (.656"—1.000"—.092")	1	
19	37-4259	Adjuster—chain, R.H.	1	
20	14-0107	Screw—chain adjuster ($\frac{1}{4}$ " U.N.F. x $1\frac{1}{2}$ " U.H.)	2	
21	14-0301	Nut—chain adjuster screw ($\frac{1}{4}$ " U.N.F.)	2	
22	37-4272	Bolt—disc to sprocket	4	
23	14-1903	Nut—disc/sprocket bolt ($\frac{3}{8}$ " U.N.F. self-locking)	4	
24	70-8770	Washer—disc/sprocket nut (.390"—.625"—.064")	4	
25	71-4045	Washer—disc/sprocket bolt (.445"—.687"—.032")	4	
26	37-4209	Sprocket—50 teeth	1	
27	37-4362	Adjuster—chain L.H.	1	
28	83-5870	Adjuster plate—assembly, L.H.	1	
29	60-4403	Speedometer drive unit (Smith's BG 5333/164)	1	
30	37-4213	Spacer—hub/speedometer drive unit	1	
31	57-1070	Bearing—L.H.	1	
32	37-4135	Grease retainer—L.H. bearing	1	
33	37-4215	Driving ring—speedometer unit	1	
34	37-3969	Balance weight—short	As required	
35	37-3970	Balance weight—long	As required	
36	37-3468	Security bolt	2	

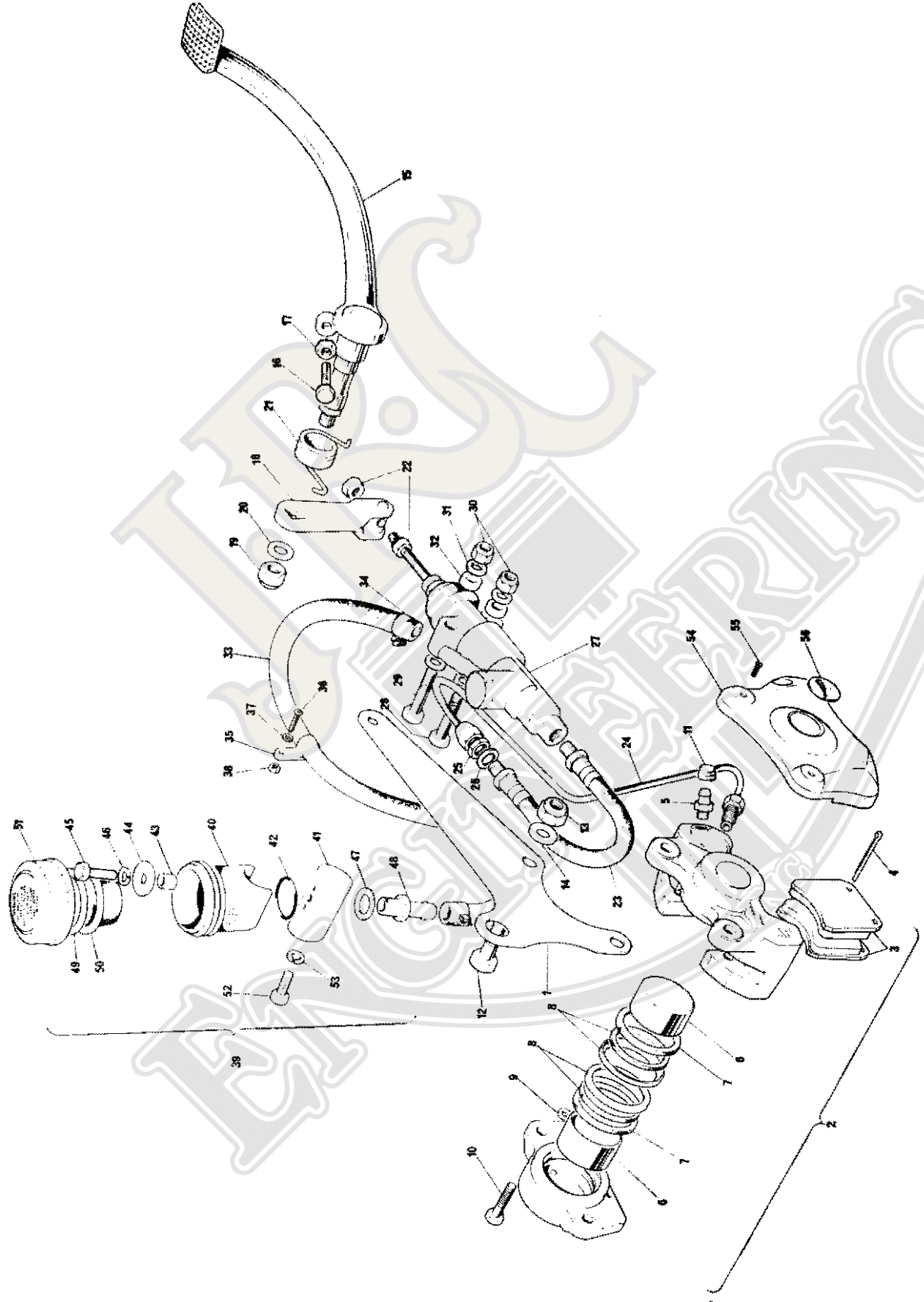

FIG. 25. REAR BRAKE

Ref. No.	Triumph Part No.	Makers Part No.	DESCRIPTION	QUANTITY	REMARKS
REAR BRAKE					
1	83-5230		Anchor plate	1	
2	60-4101	4823—432	Caliper	1	
3		4741-570	*Brake pad	2	*Available as a
4		K19866c.p	*Retaining pin	2	Service kit
5		28696	Bleed nipple	1	No. 99-2769
6	99-2765	3275-428	Piston	2	
7	99-2766	96498	Fluid seal	2	
8	99-2767	SSB72075	Retainer	2	
9		102799	Fluid seal	1	
10		3437-307	Bolt	2	
11	60-4266	363400	Cover—bleed nipple	1	
12	21-2330		Bolt—caliper to anchor plate ($\frac{3}{8}$ " U.N.F. \times 1 $\frac{3}{8}$ " U.H.)	2	
13	14-1203		Nut—caliper/anchor plate bolt ($\frac{3}{8}$ " U.N.F. self-locking)	2	
14	60-2340		Washer—caliper/anchor plate bolt (.390"—.875"—.072")	2	
15	83-5704		Brake pedal	1	
16	14-0103		Screw, adjuster—stop lite ($\frac{1}{4}$ " U.N.F. \times $\frac{3}{4}$ " U.H.)	1	
17	14-0401		Nut—adjuster screw ($\frac{1}{4}$ " U.N.F.)	1	
18	83-5401		Brake lever—pinch rod	1	
19	14-1303		Nut—brake lever/pedal ($\frac{3}{8}$ " U.N.F. self-locking)	1	
20	60-2322		Washer, for nut (.395"—.750"—.072")	1	
21	83-5366		Spring, return—brake pedal	1	
22	21-2243		Nut, adjuster—push rod ($\frac{5}{16}$ " U.N.F.)	2	Shouldered
23	60-4414	KL100001cs	Hose—master cylinder to pipe	1	
24	60-4415	ZTA2201N	Pipe—hose to caliper	1	
25	60-4180	K24103	Nut—hose to eyebolt	1	
26	70-2288	K19407	Washer, serrated—hose to eyebolt	1	
27	60-4401	4211-127†	Master cylinder—complete	1	†Service kit
28	14-0120		Bolt—master cylinder to frame ($\frac{5}{16}$ " U.N.F. \times 2 $\frac{1}{4}$ " U.H.)	1	available
29	14-0121		Bolt—master cylinder to frame ($\frac{5}{16}$ " U.N.F. \times 2 $\frac{1}{2}$ " U.H.)	1	Part No. 19-4700
30	14-1302		Nut—master cylinder/frame bolt ($\frac{5}{16}$ " U.N.F. self-locking)	2	
31	60-2330		Washer, for nut—(.333"—.625"—.040")	4	
32	82-9092		Spacer—master cylinder to frame	2	
33	60-4409	9206-2050	Hose—reservoir to master cylinder	1	
34	60-4580		Clip—hose	2	
35	60-4581		Clip—hose, P type	2	
36	21-2332		Screw—'P' clip (No. 6—40 U.N.F. \times $\frac{1}{2}$ " U.H.)	2	
37	60-4584		Washer, serrated—'P' clip screw	2	
38	21-2333		Nut—'P' clip screw (No. 6—40 U.N.F.)	2	
39	83-5465		Reservoir—assembly	1	
40	60-4397	3251/796	Body—reservoir	1	
41	83-5466		Mounting—reservoir	1	
42	60-4374	3855/814	'O' ring	1	
43	60-4398	3517/221	Distance piece	1	
44	60-4399	3512/305	Washer, plain	1	
45	14-0102		Bolt—body to mounting ($\frac{1}{4}$ " U.N.F. \times $\frac{5}{8}$ " U.H.)	1	
46	60-2427		Washer, spring—for bolt	1	
47	60-4597		Washer, sealing	1	
48	83-5467		Outlet stub	1	
49	60-4328		Washer—paper	1	
50	60-4366	3818—747	Diaphragm	1	
51	60-4365	3847-240	Filler cap	1	
52	14-0102		Bolt—mounting to battery carrier ($\frac{1}{4}$ " U.N.F. \times $\frac{5}{8}$ " U.H.)	1	
53	60-2427		Washer, spring—for bolt	1	
54	37-4263		Cover—caliper	1	
55	21-2335		Screw—caliper cover (No. 6 \times 32 U.N.C.)	2	Countersunk head
56	60-4156		Decal—caliper cover	1	

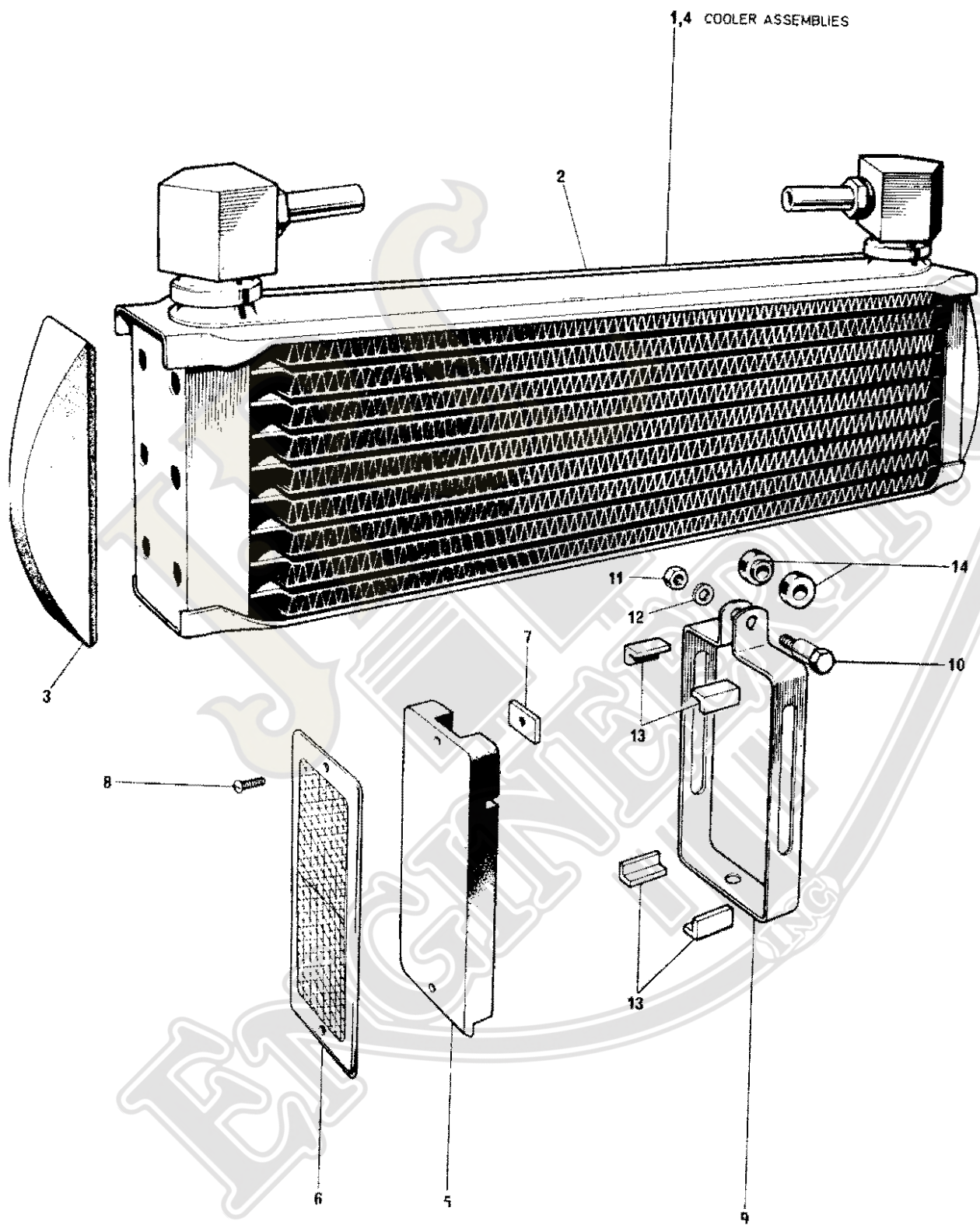

Fig. 26. OIL COOLER

Ref. No.	Part No.	DESCRIPTION	QUANTITY	REMARKS
OIL COOLER				
1	83-5863	Oil cooler—assembly	1	} Not North America
2	83-5864	Oil cooler	1	
3	83-5860	End cap—styling...	2	} North America only
4	83-5869	Oil cooler—assembly	1	
2	83-5864	Oil cooler	1	}
5	82-9907	Reflector mounting rubber assembly	2	
6	60-1990	Reflector, reflex—amber. (Lucas RER. 22-57610)	2	}
7	82-9573	Nut—reflector securing	4	
8	21-1940	Screw—securing nut (4 B.A. × $\frac{3}{16}$ " U.H.)	4	}
9	82-9317	Support strap	2	
10	82-9323	Bolt, clamp—support strap	2	}
11	82-4717	Nut—clamp bolt (2BA)	2	
12	70-2351	Washer—clamp bolt (.203"—.375"—.036")	2	}
13	82-9322	Rubber packing—corner	8	
14	82-9321	Rubber bush	4	}

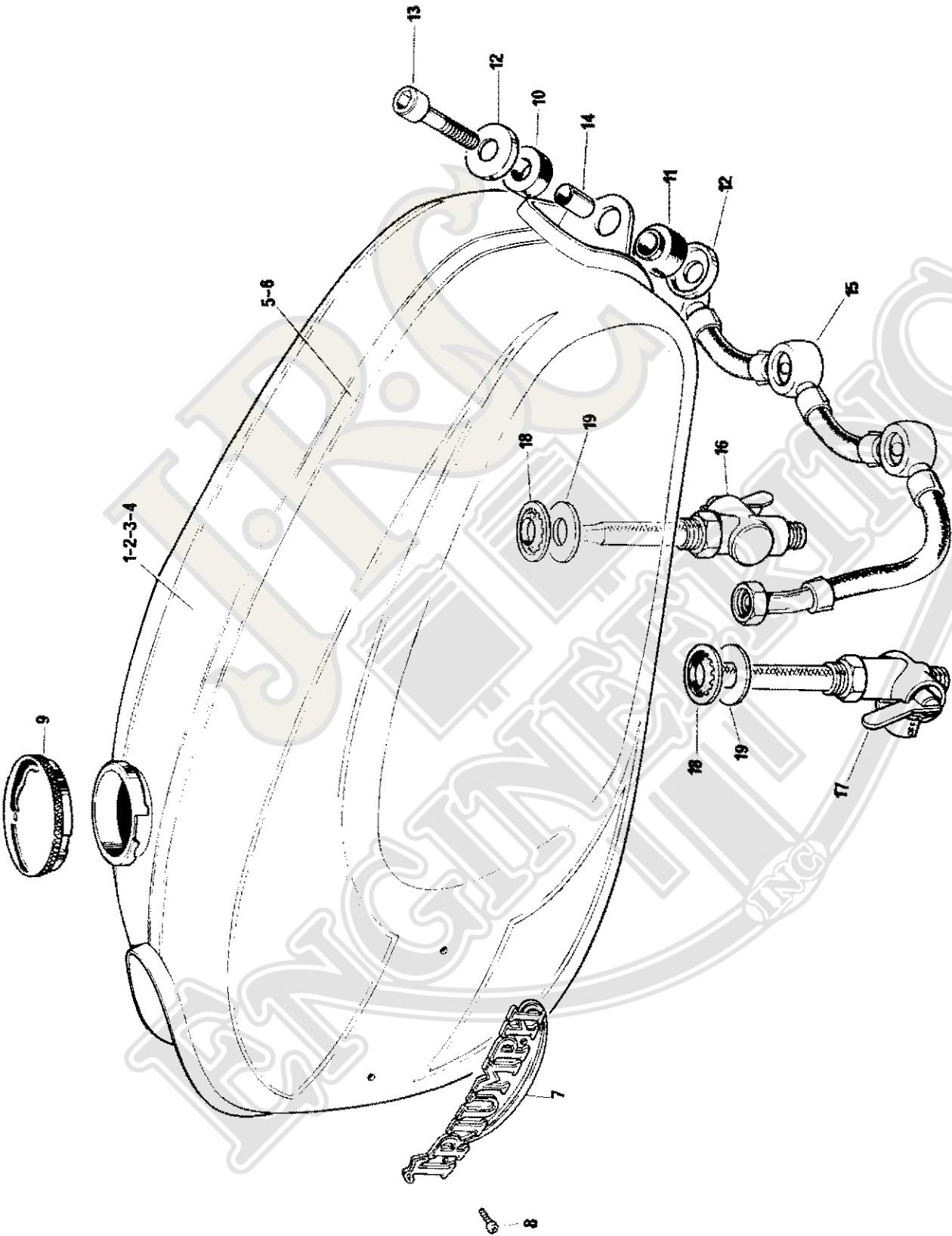

Fig. 27. GAS TANK AND PIPES

Ref. No.	Part No.	DESCRIPTION	QUANTITY	REMARKS
GAS TANK AND PIPES				
1	83-5393	Gas tank (2½ gallons)	*A
2	83-5806	Gas tank (4½ gallons)	*A
3	83-5848	Gas tank (2½ gallons)	*A
4	83-5847	Gas tank (4½ gallons)	*A
5	60-4574	Center decal (4½ gallon tank)...	...	*A
6	60-4575	Center decal (2½ gallon tank)	...	*A
7	83-5361	Badge—"Triumph"	2
8	21-2064	Screw—badge to tank (No. 8 × 32 U.N.C. × ⅜" U.H.)	...	4
9	83-3875	Filler cap—with joint washer	...	1
10	83-5617	Rubber washer—plain	...	1
11	83-5618	Rubber washer—spigotted	...	1
12	83-5616	Cup—for rubber	...	2
13	14-1022	Screw—tank mounting	...	1 Socket head
14	83-5610	Spacer tube	...	1
15	82-9436	Gas pipe-line—assembly	...	1
16	60-4511	Gas tap—main	...	1
17	60-4512	Gas tap—reserve	...	1
18	70-7351	Washer, sealing—gas tap	...	2
19	83-0002	Washer, plain—gas tap	...	2

Colors

83-5393 and 83-5806

White, with yellow panels & gold lining

83-5847 and 83-5848

Bergundy red, with white panels & gold lining

*The symbol 'A' indicates that these items are alternative fitments, and the capacity of the tank as fitted to the machine should be checked before ordering

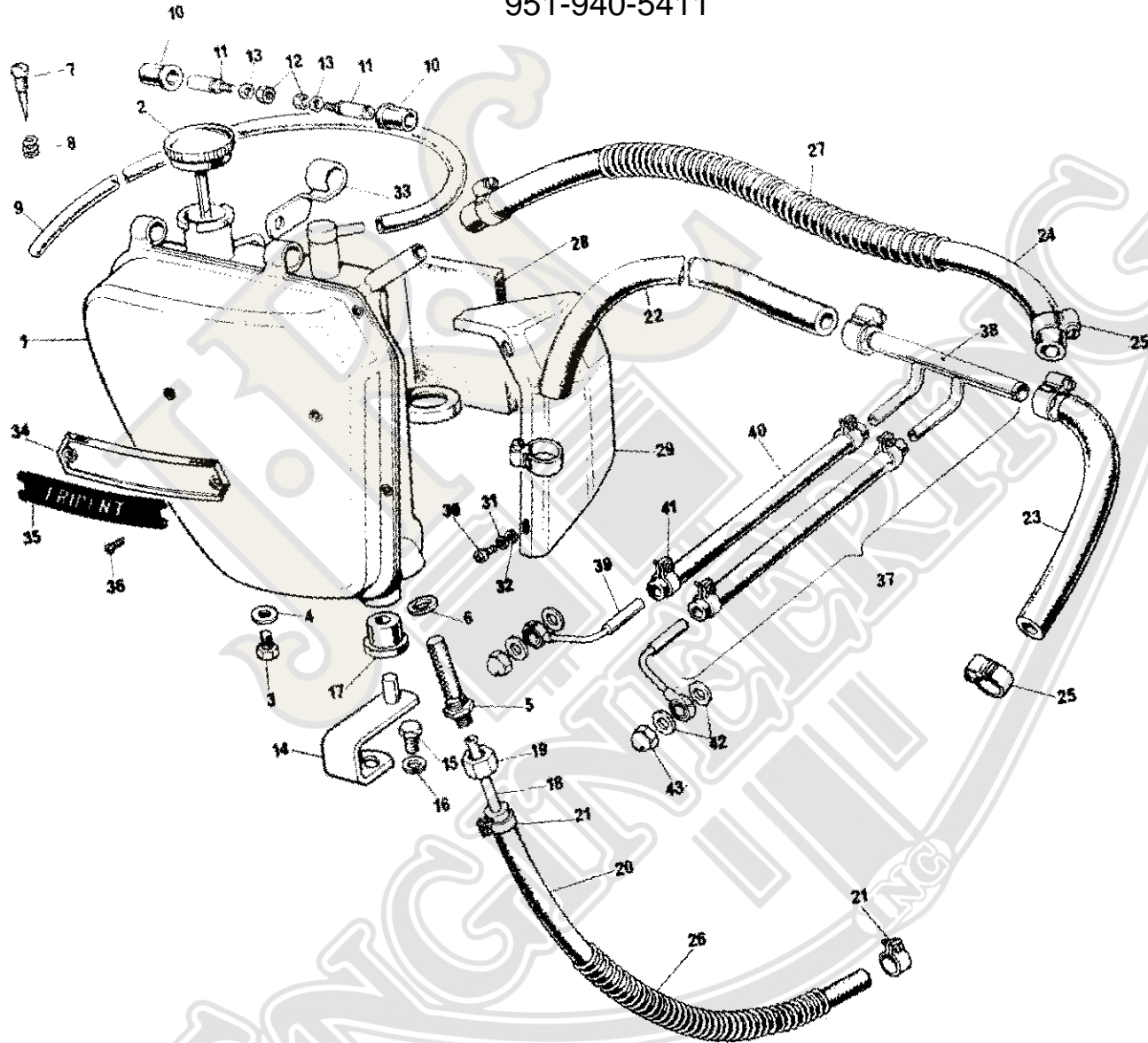

Fig. 28. OIL TANKS AND PIPE LINES

Ref. No.	Part No.	DESCRIPTION	QUANTITY	REMARKS
OIL TANK AND PIPE LINES				
1	83-4984	Oil tank	1	
2	82-9659	Fillar cap	1	
3	82-5343	Drain plug	1	
4	60-4262	Washer—drain plug (.386"—625"—.062") Fiber	1	
5	83-5892	Filter—assembly	1	
6	82-1713	Washer—filter	1	
7	82-9435	Metering screw—chain oiler	1	
8	82-6874	Spring—metering screw	1	
9	82-9664	Extension pipe, flexible—froth tower	1	
10	82-6673	Rubber, front and rear—oil tank to frame	2	
11	82-7510	Peg—oil tank to frame	2	
12	14-1301	Nut—for peg ($\frac{1}{4}$ " U.N.F., self-locking)	2	
13	60-4248	Washer—peg nut (.265"—469"—.064")	2	
14	83-5276	Bracket—tank to mounting, bottom	1	
15	21-1822	Bolt—mounting bracket ($\frac{3}{16}$ " U.N.F. \times $\frac{1}{2}$ " U.H.)	1	
16	60-4260	Washer, spring—mounting bracket bolt (.328"—562"—.064")	1	
17	82-6039	Grommet—mounting bracket	1	
18	83-5890	Feed pipe—top half	1	
19	83-5891	Nut—feed pipe union	1	
20	70-8904	Feed pipe, flexible—tank to engine	1	
21	70-6848	Clip, feed pipe—tank and engine	2	
22	71-3785	Return pipe, flexible—engine to rocker feed (40" long)	1	
23	71-3786	Pipe, flexible—rocker feed to oil cooler (9 $\frac{1}{2}$ " long)	1	
24	83-5390	Pipe, flexible—cooler to tank (27 $\frac{3}{4}$ " long)	1	
25	60-0702	Clip—flexible pipes	6	Worm type
26	82-9530	Protection spring—feed pipe	1	
27	82-9531	Protection spring—return pipe	1	
28	83-5015	Battery pad—oil tank	1	
29	83-5362	Styling cover—oil tank	1	
30	21-2326	Screw—styling cover—(No. 10 \times 32 U.N.F. \times $\frac{1}{2}$ " U.H.)	2	
31	60-2416	Washer, spring—styling cover screw (.202"—330"—.064")	2	
32	60-2391	Washer, plain—styling cover screw (.202"—390"—.032")	2	
33	83-1549	Clip—choke control junction block	1	
34	60-4427	Name plate	1	
35	60-4569	Name motif—"Trident"	1	
36	82-4129	Screw—nameplate (2 B.A. \times $\frac{1}{2}$ " U.H.)	2	
37	71-4181	Rocker oil pipe—assembly	1	
38	71-4182	Rocker oil pipe—engine to cooler	1	
39	71-4185	Rocker oil pipe—spindle connection	2	
40	71-1175	Connecting tube	2	
41	70-6848	Clip—connecting tube	4	
42	70-1335	Joint washer—banjo connection	4	
43	21-0550	Nut, domed—banjo connection	2	

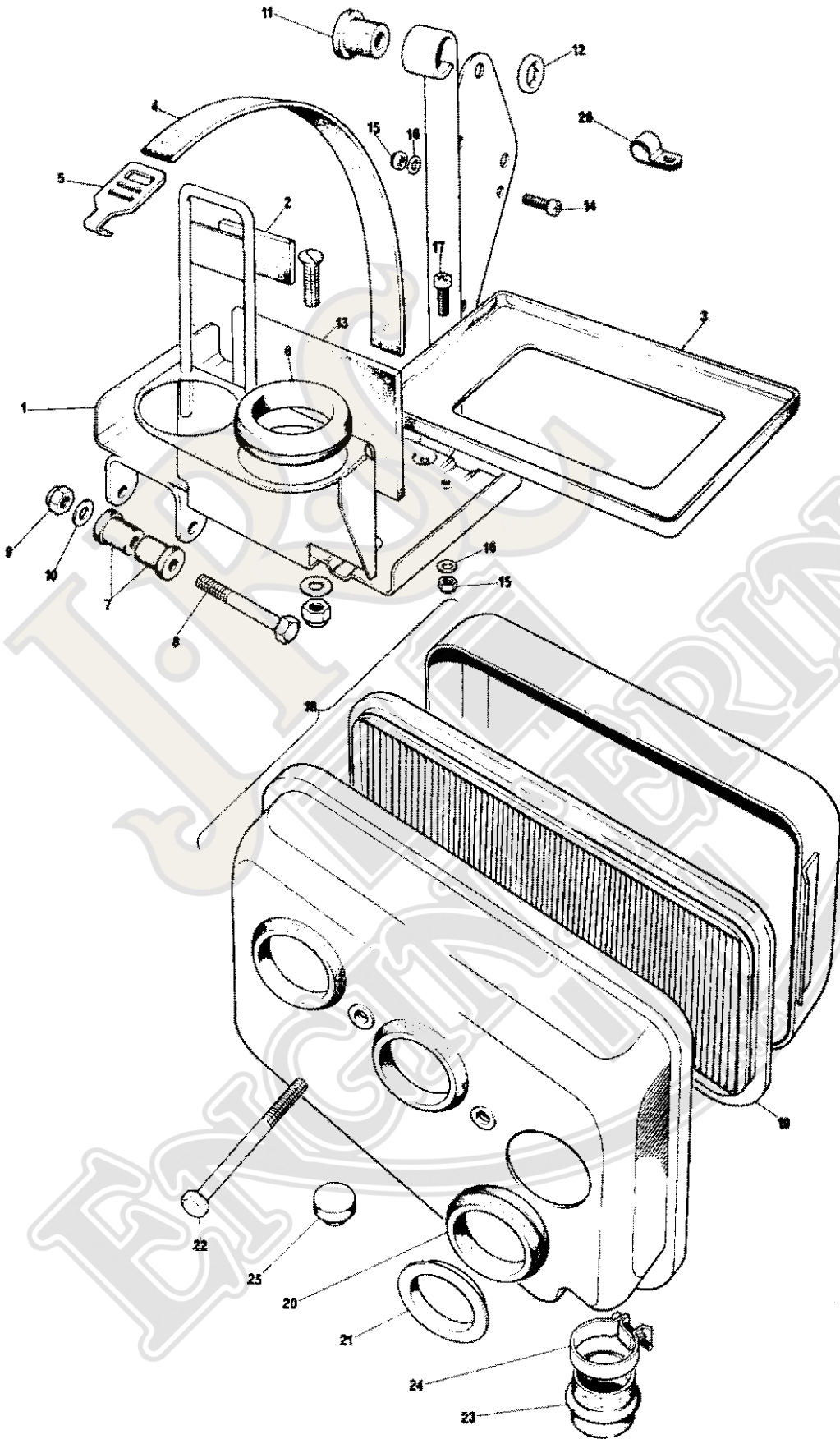

Fig. 29. BATTERY CARRIER AND FILTER

Ref. No.	Part No.	DESCRIPTION	QUANTITY	REMARKS
BATTERY CARRIER AND AIR FILTER				
1	83-4985	Battery and coil carrier—assembly	1	
2	83-5486	Rubber pad—battery carrier, front... ..	1	
3	83-2175	Mat, for battery	1	
4	82-9353	Strap—battery retaining	1	
5	83-5485	Hook—battery strap	1	
6	82-9561	Grommet—coil mounting	3	
7	82-6673	Rubber bush—battery carrier bottom fixing	2	
8	14-0223	Bolt—carrier bottom fixing ($\frac{7}{16}$ " U.N.F. \times $2\frac{1}{2}$ ")	1	
9	14-1302	Nut—carrier bottom fixing bolt ($\frac{7}{16}$ " U.N.F., self-locking)	1	
10	60-2321	Washer, for nut (.333" \times .625" \times .072")	1	
11	82-6673	Rubber bush—battery carrier top fixing	1	
12	82-8245	Spring ring—carrier top fixing bush	1	
13	83-5014	Battery pad—coil tray	1	
14	21-2079	Screw—condenser, flasher unit, starter relay (No. 10—32 U.N.F. \times $\frac{1}{2}$ " U.H.)	5	
15	21-0778	Nut—condenser, flasher, starter unit (No. 10 U.N.F., self-locking)	6	
16	60-2391	Washer, for nut (.202"—.391"—.032")	6	
17	21-2079	Screw—starter relay (No. 10—32 U.N.F. \times $\frac{1}{2}$ " U.H.)	1	
18	83-5096	Air filter/silencer—assembly	1	
19	83-5092	Filter—air cleaner	1	
20	82-9562	Grommet—air filter box	3	
21	70-9586	Sleeve—carburetor intake	3	
22	14-0213	Bolt—air filter/silencer to carburetor adaptor ($\frac{1}{4}$ " U.N.F. \times $3\frac{1}{2}$ " U.H.)	2	
23	83-5434	Hose, breather—air filter box to crankcase	1	
24	60-4433	Clip—breather hose	2	
25	82-7835	Rubber buffer—air filter box support	1	
26	83-5168	Clip—electrical harness	1	

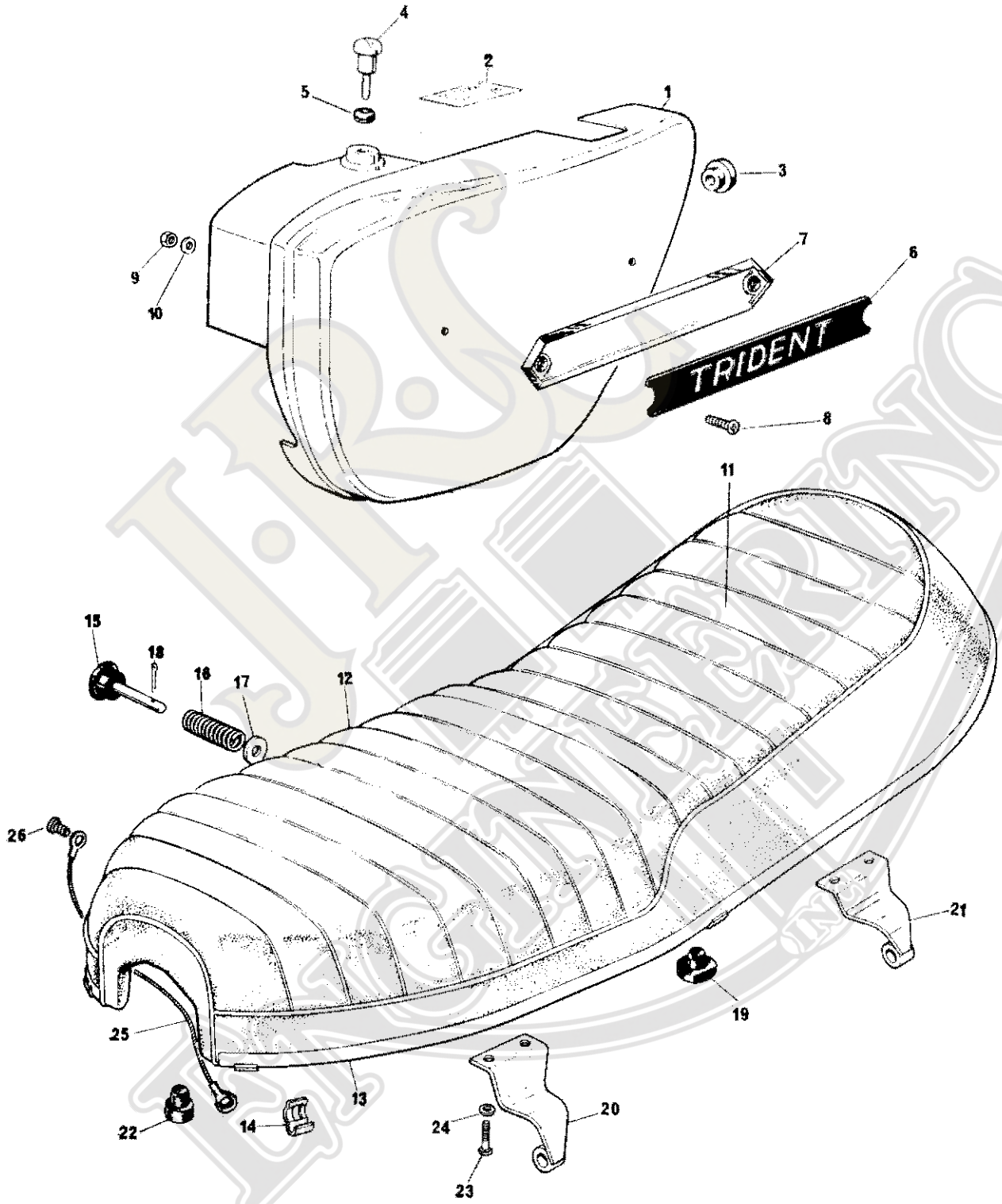

Fig. 30. SIDE PANEL AND TWINSEAT

Ref. No.	Part No.	DESCRIPTION	QUANTITY	REMARKS
SIDE PANEL AND TWINSEAT				
1	83-5690	Side Panel, L.H.—assembly	1	
2	60-0052	Decal—battery (positive earth)	1	
3	82-6673	Rubber bush—panel rear fixing	2	
4	82-9445	Release knob	1	
5	60-3161	Grommet—top fixing	1	
6	60-4569	Name motif "Trident"	1	
7	60-4336	Nameplate	1	
8	82-4129	Screw—nameplate (2 B.A. $\times \frac{1}{2}$ " U.H.)	2	
9	82-4717	Nut—nameplate screw (2 B.A.)	2	
10	60-2391	Washer, plain—nameplate screw ($\cdot 202$ "— $\cdot 390$ "— $\cdot 032$ ")	2	
11	83-5309	Twinseat—complete	1	
12	83-5378	Cover only	1	
13	60-0696	Trim strip	1	
14	60-0697	Sprag—trim strip	4	
15	82-7560	Plunger—twinseat catch	1	
16	82-4228	Spring—plunger	1	
17	70-1719	Washer—plunger spring ($\cdot 328$ "— $\cdot 531$ "— $\cdot 016$ ")	1	
18	60-2720	Split pin—plunger washer	1	
19	82-4898	Buffer	2	
20	82-8026	Hinge, front	1	
21	82-7862	Hinge, rear	1	
22	82-7835	Buffer	2	
23	14-0101	Bolt—hinge ($\frac{1}{4}$ " U.N.F.— $\frac{1}{2}$ " U.H.)	4	
24	60-4250	Washer, spring—hinge bolt ($\cdot 265$ "— $\cdot 41$ "— $\cdot 064$ ")	4	
25	60-2087	Check wire	1	
26	60-2381	Screw—check wire terminal	1	

74

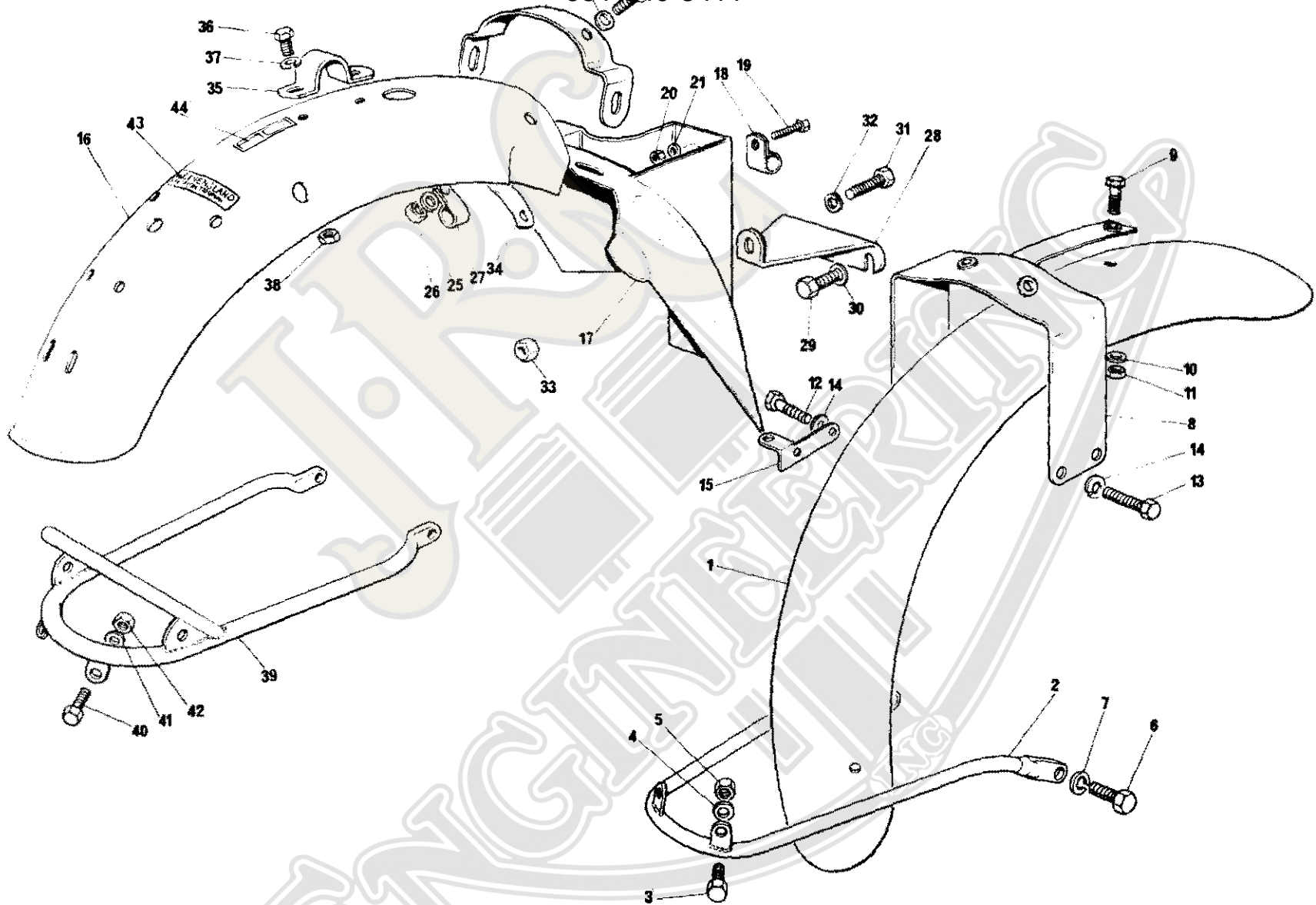

Fig. 31. FENDERS AND STAYS

Ref. No.	Part No.	DESCRIPTION	QUANTITY	REMARKS
FENDERS AND STAYS				
1	97-5053	Front fender	1	
2	97-4552	Rear stay	1	
3	14-0101	Bolt—rear stay to fender ($\frac{1}{4}$ " U.N.F. \times $\frac{1}{2}$ " U.H.)	2	
4	60-4245	Washer—rear stay bolt (.265"—.562"—.080")	2	
5	14-1201	Nut—rear stay bolt ($\frac{1}{4}$ " U.N.F., self-locking)	1	
6	14-6114	Bolt—rear stay to fork ($\frac{5}{16}$ " U.N.F. \times $\frac{3}{4}$ " U.H.)	2	
7	60-2428	Washer, spring—rear stay bolt	2	
8	97-5058	Bridge piece, complete	1	
9	14-2204	Screw—bridge piece to fender ($\frac{1}{4}$ " U.N.F. \times $\frac{1}{2}$ " U.H.)	3	Pan head
10	60-4245	Washer, plain—bridge piece screw (.265"—.562"—.080")	3	
11	14-1201	Nut—bridge piece screw ($\frac{1}{4}$ " U.N.F., self-locking)	3	
12	14-0104	Bolt—bridge and pipe bracket to fork, L.H. ($\frac{1}{4}$ " U.N.F. \times $\frac{7}{8}$ " U.H.)	2	
13	14-0103	Bolt—bridge piece to fork, R.H. ($\frac{1}{4}$ " U.N.F. \times $\frac{3}{4}$ " U.H.)	2	
14	60-2427	Washer, spring—bridge piece bolt	4	
15	97-5055	Bracket—hydraulic pipe	1	
16	83-5874	Rear fender—rear portion	1	
17	83-5474	Rear fender—front portion, with toolbox	1	
18	82-3808	Clip—electrical harness to toolbox	1	
19	14-0102	Bolt—harness clip ($\frac{1}{4}$ " U.N.F. \times $\frac{5}{8}$ " U.H.)	1	
20	14-1301	Nut—harness clip bolt ($\frac{1}{4}$ " U.N.F., self-locking)	1	
21	60-2320	Washer, plain—harness clip bolt (.265"—.562"—.056")	2	
22	82-6915	Bridge—fender, front and rear portions	1	
23	14-0103	Bolt—bridge to fender ($\frac{1}{4}$ " U.N.F. \times $\frac{3}{4}$ " U.H.)	2	
24	82-6310	Washer—bridge bolt (.265"—.937"—.064")	2	
25	60-4245	Washer—bridge bolt (.265"—.562"—.080")	2	
26	14-1201	Nut—bridge bolt ($\frac{1}{4}$ " U.N.F., self-locking)	2	
27	83-5168	Clip—electrical harness to bridge	1	
28	83-4968	Bracket—fender front portion, bottom fixing	1	
29	21-1822	Bolt—bracket to pivot lug ($\frac{5}{16}$ " U.N.F. \times $\frac{1}{2}$ " U.H.)	2	
30	60-4260	Washer, spring—bracket/pivot lug bolt	2	
31	14-0102	Bolt—bracket to fender ($\frac{1}{4}$ " U.N.F. \times $\frac{5}{8}$ " U.H.)	1	
32	82-6310	Washer—bracket/fender bolt (.265"—.937"—.064")	1	
33	14-1201	Nut—bracket/fender bolt ($\frac{1}{4}$ " U.N.F., self-locking)	1	
34	82-6031	Backing plate—fender rear fixing	1	
35	82-5994	Clip, top—fender to top rail	1	
36	14-0113	Bolt—clip to fender ($\frac{5}{16}$ " U.N.F. \times $\frac{5}{8}$ " U.H.)	2	
37	60-4247	Washer, spring—clip bolt	2	
38	14-1302	Nut—clip bolt ($\frac{5}{16}$ " U.N.F., self-locking)	2	
39	83-5147	Lifting handle	1	
40	14-0102	Bolt—lifting handle to fender ($\frac{1}{4}$ " U.N.F. \times $\frac{5}{8}$ " U.H.)	2	
41	60-2347	Washer—lifting handle bolt (.270"—.625"—.040")	4	
42	14-1201	Nut—lifting handle bolt ($\frac{1}{4}$ " U.N.F., self-locking)	2	
43	60-4556	Decal—"Made in England"	1	
44	60-1816	Decal—oil change recommendations	1	

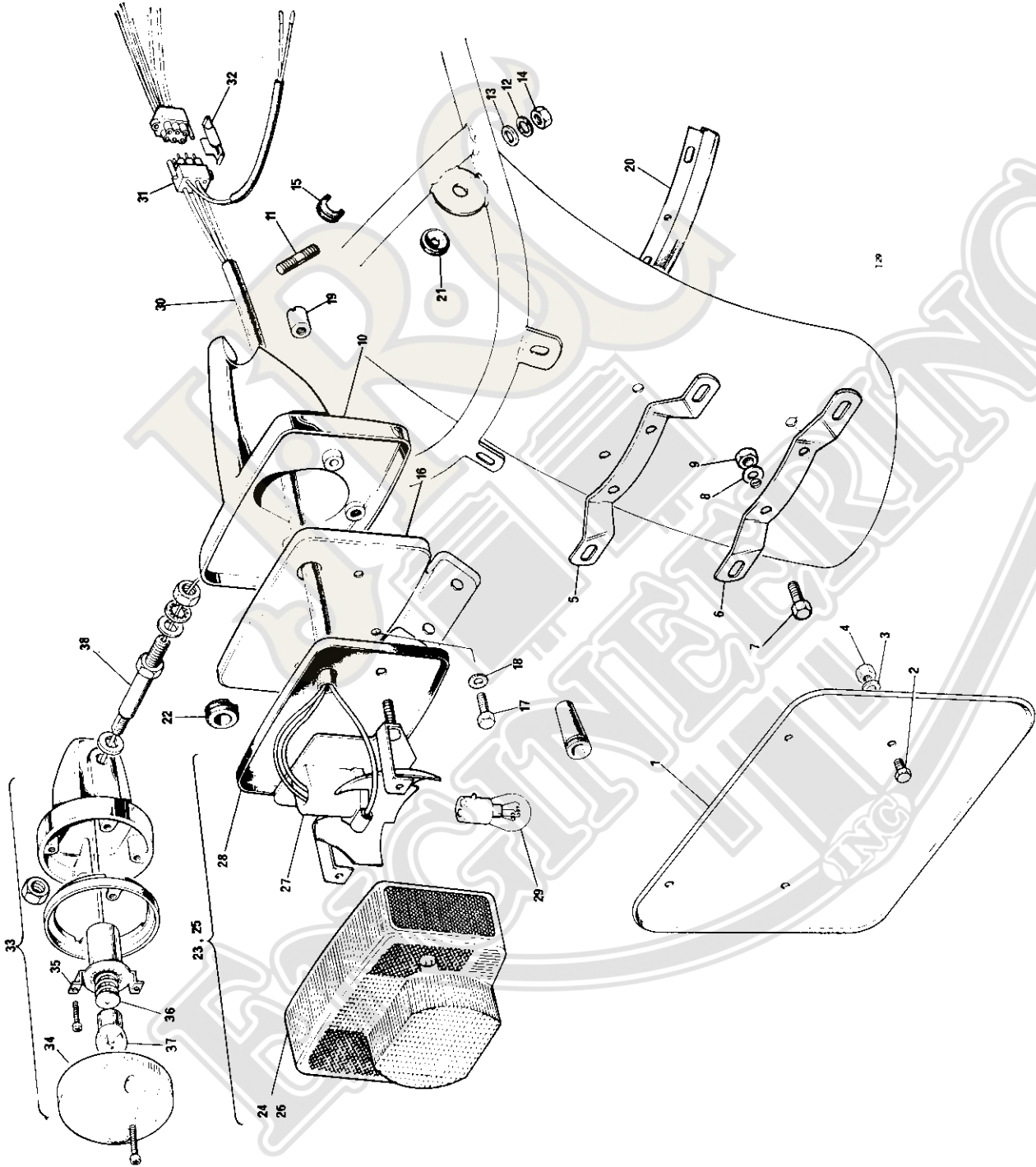

FIG. 32. REAR LITE AND INDICATOR LITE

Ref. No.	Triumph Part No.	Makers Part No.	DESCRIPTION	QUANTITY	REMARKS
REAR LITE AND INDICATOR LITE					
1	83-2726		Rear number plate	1	
2	14-0101		Bolt—number plate fixing ($\frac{1}{4}$ " U.N.F. \times $\frac{1}{2}$ " U.H.) ...	4	
3	60-2329		Washer—plate fixing bolt	4	
4	14-1301		Nut—plate fixing bolt ($\frac{1}{4}$ " U.N.F. self-locking) ...	4	
5	83-4784		Bracket, top—rear number plate	1	
6	82-6850		Bracket, bottom—rear number plate	1	
7	14-0102		Bolt—brackets to fender ($\frac{1}{4}$ " U.N.F. \times $\frac{5}{8}$ " U.H.) ...	4	
8	60-2347		Washer—bracket/fender bolt (-270"—625"—040")	4	
9	14-1301		Nut—bracket/fender bolt ($\frac{1}{4}$ " U.N.F. self-locking) ...	4	
10	83-4774		Rear lite carrier	1	
11	21-2225		Stud—lite carrier	1	
12	60-4250		Washer, spring—lite carrier stud	1	
13	60-2347		Washer, plain—lite carrier stud (-270"—625"—040")	1	
14	14-0301		Nut—lite carrier stud ($\frac{1}{4}$ " U.N.F.)	1	
15	83-5105		Grommet—rear lite carrier	2	
16	83-5001		Support plate—rear lite	1	
17	14-7804		Screw—support plate to lite carrier	1	
18	70-1612		Washer, serrated—support plate screw	1	
19	83-4800		Nut—rear lite securing	2	
20	83-4806		Protection strip—cables	1	
21	60-4103		Grommet—indicator cables	2	
22	97-0961		Grommet—rear lite cables	2	
23	60-4110	L91756515	Rear lite (less side reflex)	1	Except N. America
24		54585314	Lens (with screws)	1	
25	60-4109	L91756513	Rear lite (with side reflex)	1	N. America only
26	99-1257	54584930	Lens (with screws)	1	
27		54584931	Base assembly	1	
28		54583924	Gasket	1	
29	99-0542	380	Bulb	1	
30	60-4578		Sub wiring harness—rear lite	1	
31	60-4341	54191473	Snap connector—rear lite	1	
32	06-6139		Retaining clip—"Amp" plug and socket	1	
33	60-4105	54057566	Direction indicator lite, complete	2	
34	99-1191	54581638	Lens assembly	1	
35		54580332	Bulb holder assembly	1	
36		573832	Interior, bulbholder	1	
37	99-1192	382	Bulb	1	
38	19-1369	60600312	Stanchion, indicator lites—c.w nuts and washers	2	

78

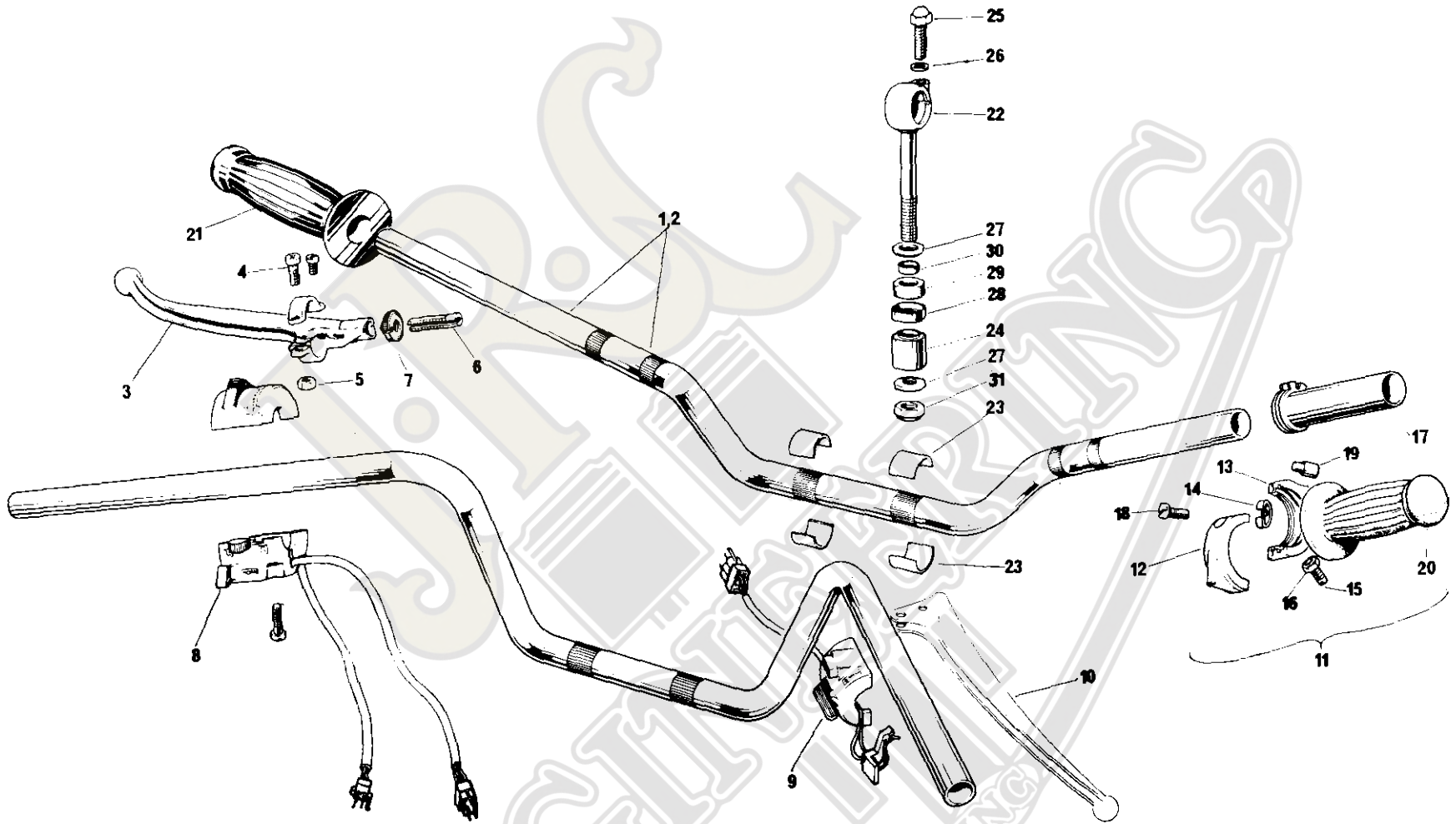

Fig. 33 HANDLEBAR AND CONTROLS

Ref. No.	Triumph Part No.	Maker's Part No.	DESCRIPTION	QUANTITY	REMARKS
HANDLEBAR AND CONTROLS					
1	97-4651		Handlebar	1	U.S.A. only
2	97-4583		Handlebar	1	Except U.S.A.
3	60-2242	19/1099	Clutch lever assembly	1	
4	21-2048	18/087	Pivot pin—clutch lever	1	
5	14-1201	18/053	Nut—pivot pin ($\frac{1}{4}$ " U.N.F.)	1	
6	60-3585		Adjuster—clutch cable	1	
7	60-3586		Lock ring—clutch cable adjuster	1	
8	60-4586	30707	Handlebar switches—assembly, left hand	1	Type 181 SA
9	60-4587	30723*	Handlebar switches—halfcap, right hand	1	Type 169 SA
10	97-4391	*	Front brake lever (also appears on page 59)	1	
11	60-4460	364/17	Twist-grip—complete assembly	1	
12		363/013	Body, top half	1	
13		364/014	Body, bottom half	1	
14		16/008	Friction spring	1	
15		364/022	Screw	1	
16		5/077	Locknut	1	
17		364/017	Rotor	1	
18	99-0225	11/013	Screw	2	
19		16/011	Stop—cable	1	
20	97-2125		Grip	1	
21	97-2142		Grip—left hand	1	
22	97-2291		Clamp—handlebar	2	
23	97-1425		Sleeve—handlebar clamp	4	
24	97-1527		Bush—handlebar clamp	2	
25	21-0589		Bolt—handlebar clamp	2	
26	82-1335		Washer—clamp bolt	2	
27	97-1529		Washer, hemispherical—clamp bolt	4	
28	97-2221		Cup—handlebar clamp	2	
29	97-1580		Washer, rubber—handlebar clamp	2	
30	97-1581		Distance piece—handlebar clamp	2	
31	14-1303		Nut—handlebar clamp	2	

*See fig. 23 for assembly details of front brake lever body, lever, and switch cap.

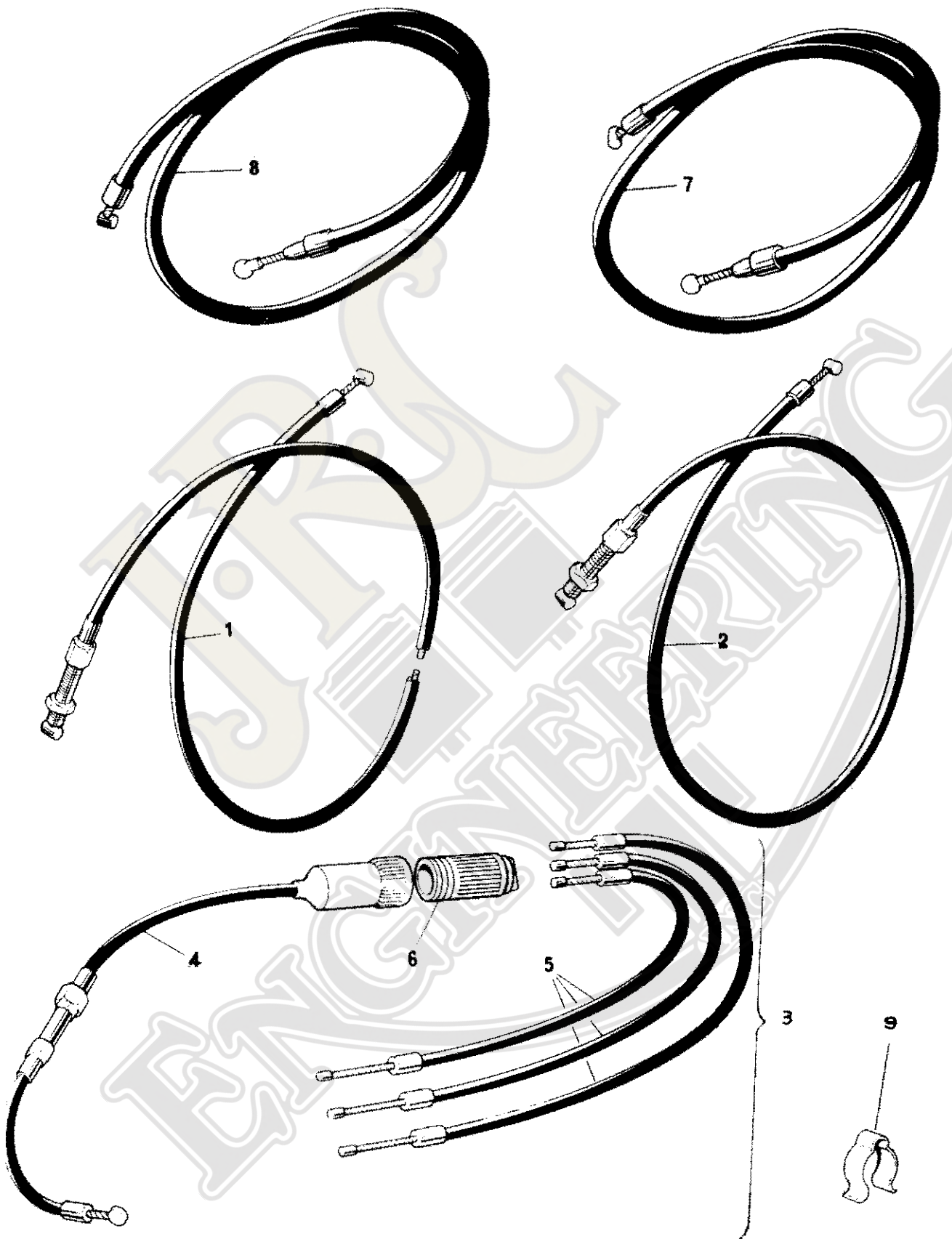
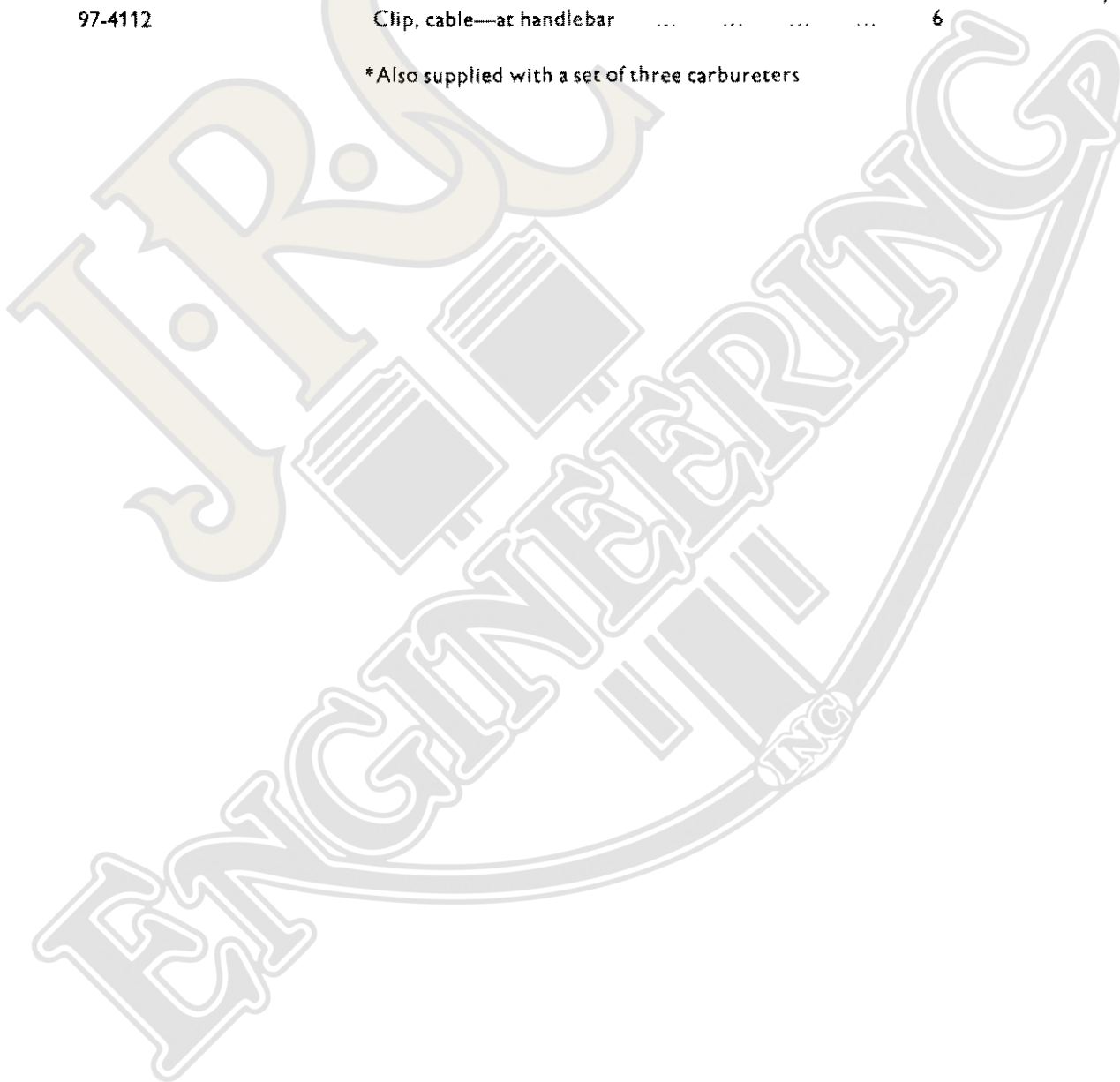

Fig. 34. CONTROL CABLES

Ref. No.	Triumph Part No.	Maker's Part No.	DESCRIPTION	QUANTITY	REMARKS
CONTROL CABLES					
1	60-4458		Throttle cable—assembled	1	N. America only
2	60-4457		Throttle cable—assembled	1	Except N. America
3	60-3565	*	Choke control cable—assembled	1	
4	60-3566		Choke control cable—lever to junction box ...	1	
5	60-2061		Choke control cable—junction box to carburetor	3	
6	60-1978	244/2080	Junction box	1	
7	60-4362		Clutch cable—assembled	1	Except N. America
8	60-4454		Clutch cable—assembled	1	N. America only
9	97-4112		Clip, cable—at handlebar	6	

*Also supplied with a set of three carbureters



1 TOOLKIT COMPLETE

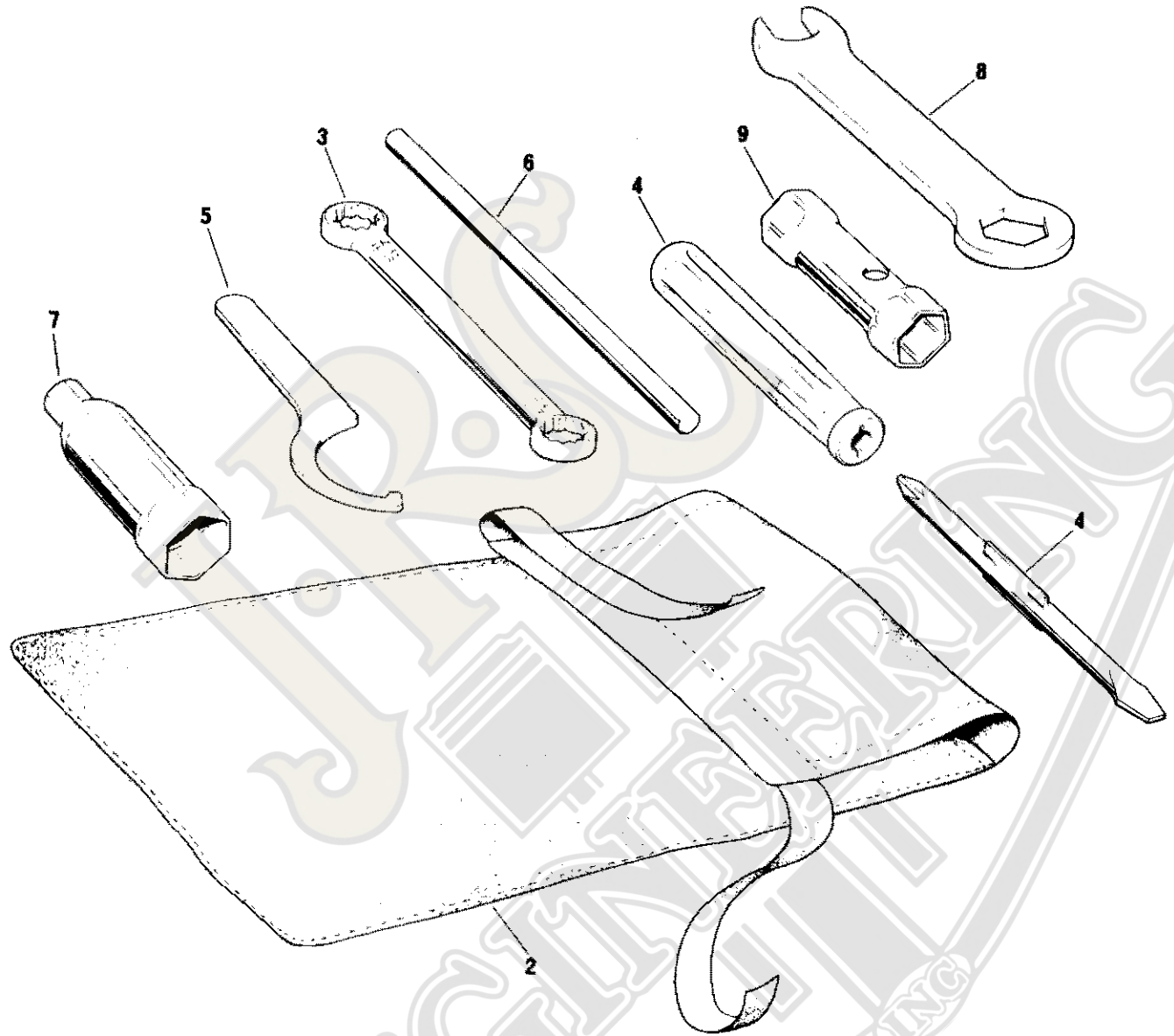

Fig. 35. TOOLKIT

Ref. No.	Part No.	DESCRIPTION	QUANTITY	REMARKS
----------	----------	-------------	----------	---------

TOOLKIT

1	60-4438	Toolkit complete	1	
2	60-0291	Tool roll	1	
3	60-1907	Ring wrench—double ended ($\frac{7}{16}$ " \times $\frac{1}{2}$ " A/F)	1	
4	60-0767	Screwdriver—reversible blade	1	
5	60-2184	'C' wrench—suspension unit.	1	
6	60-3711	Tommy bar ($\frac{5}{16}$ " dia.)	1	
7	60-1910	Wrench—spark plug ($\cdot 825$ " \times $\frac{1}{2}$ " A/F)	1	
8	60-4531	Wrench—open end/ring end ($\cdot 605$ " \times $\cdot 948$ " A/F)	1	
9	60-4539	Wrench—tubular, $\frac{9}{16}$ " \times $\frac{5}{8}$ " A/F.	1	



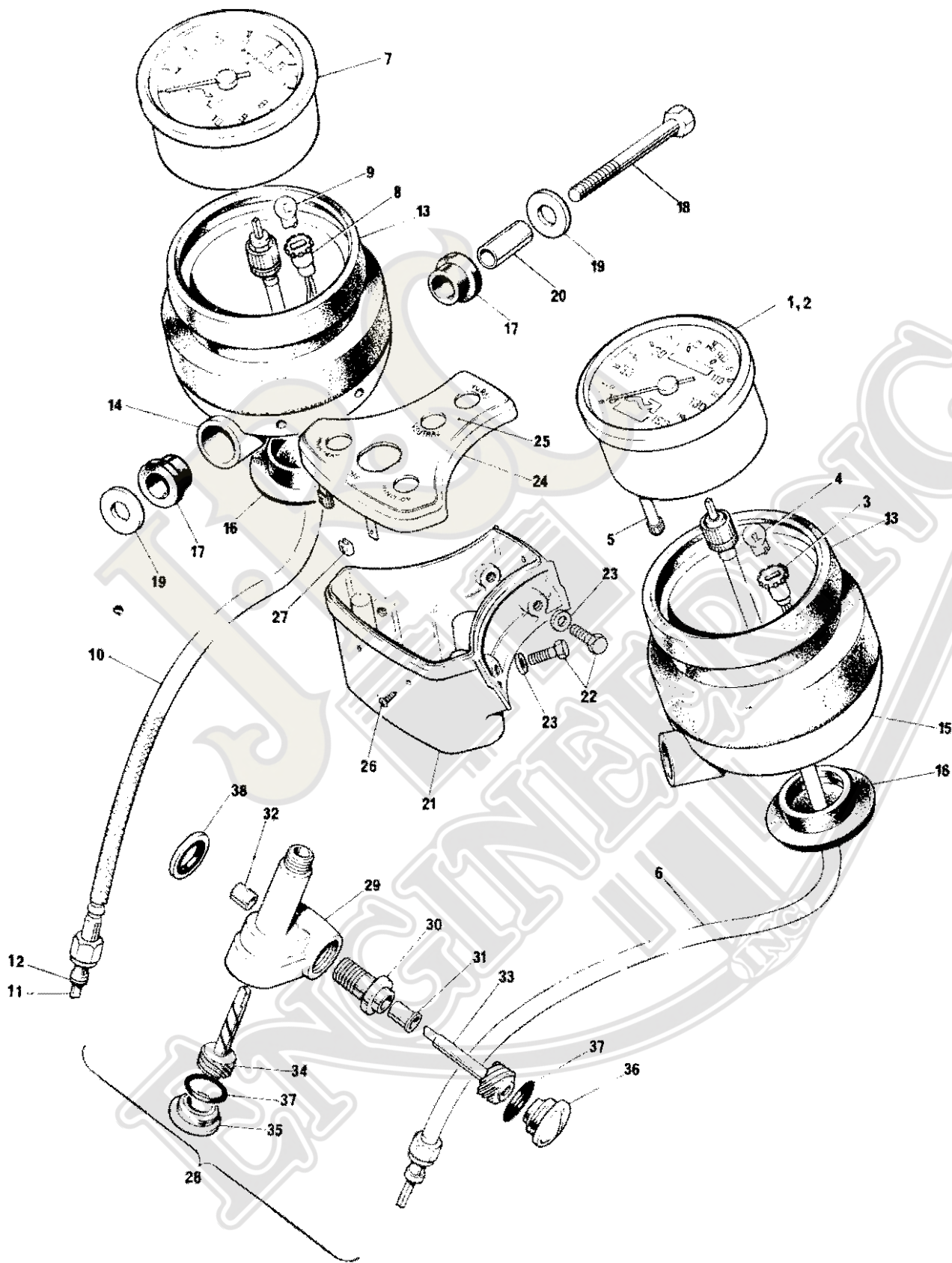

Fig. 36. SPEEDOMETER, TACHOMETER AND DRIVE, SWITCH PANEL

Ref. No.	Triumph Part No.	Maker's Part No.	DESCRIPTION	QUANTITY	REMARKS
SPEEDOMETER, TACHOMETER AND DRIVE, SWITCH PANEL					
1	60-4514	Z64551	Speedometer head—m.p.h. scale	1	
2	60-4515	Z64552	Speedometer head—km/h scale	1	
3		51271406	Bulb holder	1	
4		504	Bulb	1	
5		41/118/126/22	Trip control	1	
6	60-4455	DF9110/00	Speedometer driving cable	1	
7	60-4513	Z64553	Tachometer head	1	
8		51271406	Bulb holder	1	
9		504	Bulb	1	
10	60-4456	DF9111/03	Tachometer driving cable	1	
11	99-0173	31-371-398	Spade—tachometer cable	1	
12	60-0494		Circlip—cable spade	1	
13	97-4573		Rubber cup—instruments	2	
14	97-4574		Instrument carrier—left side	1	
15	97-4575		Instrument carrier—right side	1	
16	97-5061		Grommet—instrument carrier	2	
17	97-4588		Bush, rubber—instruments to steering yoke	4	
18	14-0235		Bolt—instruments to yoke ($\frac{3}{8}$ " U.N.F. x 2" U.H.)	2	
19	60-2340		Washer—instrument/yoke bolt (.395" — .875" — .072")	4	
20	97-4587		Spacer tube—instruments to yoke	2	
21	97-4577		Switch box	1	
22	14-6104		Screw—switch box to carrier	4	
23	60-2427		Washer, spring...	4	
24	97-5000		Panel—switch box	1	
25	60-4502		Panel—identification	1	
26	21-0762		Screw—panel to switch box (No. 10 x $\frac{3}{16}$ " U.H.)	3	
27	60-4503		Nut, captive—'U' type	3	Spire
28	71-4138		Tachometer drive gearbox—assembly	1	
29	71-4139		Body—tachometer drive gearbox	1	
30	70-9332		Securing screw—tachometer gearbox	1	
31	70-5155		Bush—flanged	1	
32	70-5156		Bush—plain	1	
33	70-5157		Driving gear—tachometer drive gearbox	1	
34	71-2653		Driven gear—tachometer drive gearbox	1	
35	71-4131		End plug—tachometer drive gearbox	1	
36	71-2480		End cap—tachometer drive gearbox	1	
37	60-3355		'O' ring, end cap—tachometer drive gearbox	2	
38	70-7351		Washer, sealing—gearbox to crankcase	1	

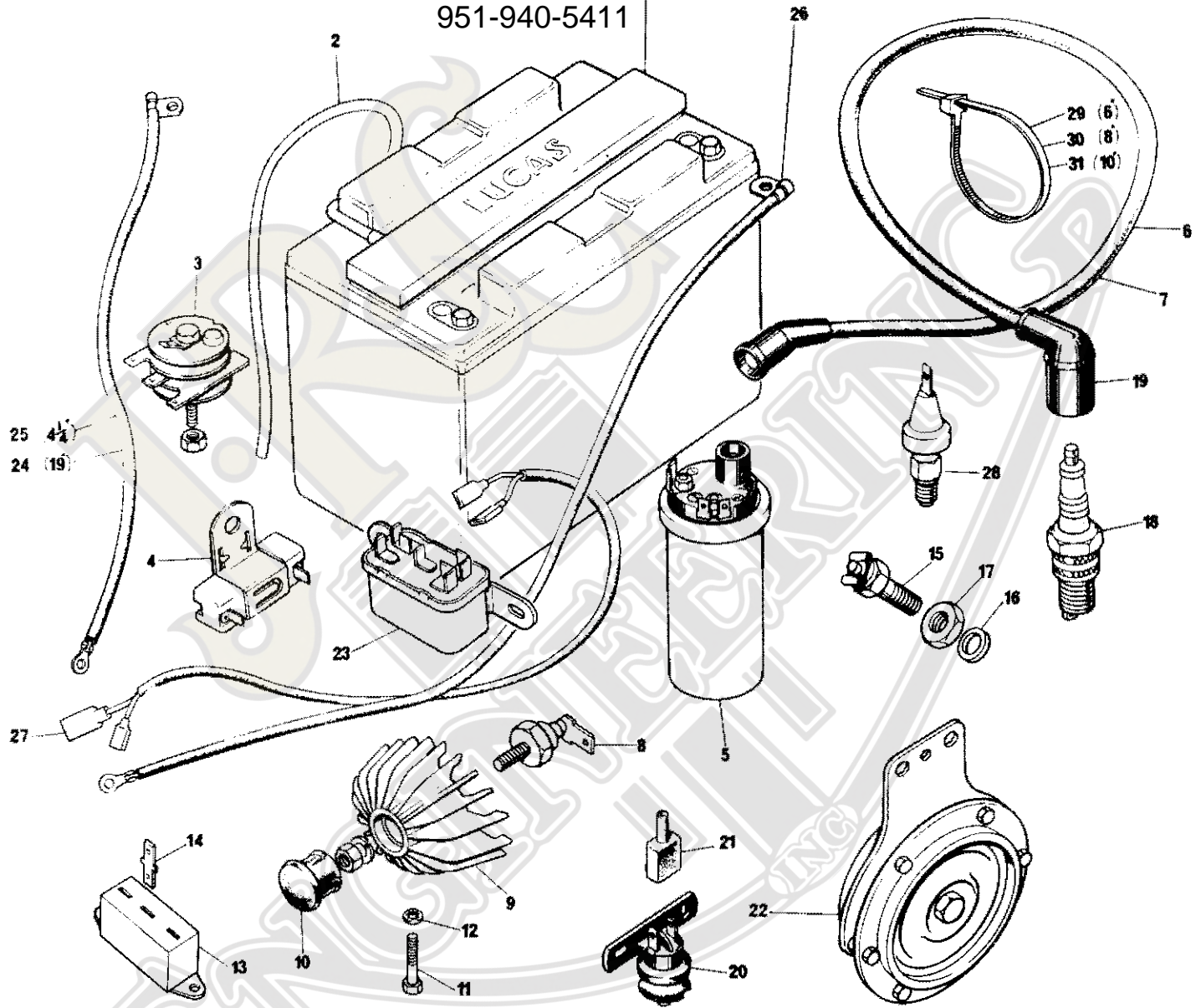

Fig. 37. ELECTRICAL EQUIPMENT—COILS, RECTIFIER, BATTERY, ETC.

Ref. No.	Triumph Part No.	Maker's Part No.	DESCRIPTION	QUANTITY	REMARKS
ELECTRICAL EQUIPMENT—COILS, RECTIFIER, BATTERY, ETC.,					
1	60-4217	54029292	Battery—Type MCZ/9—8	1	
2	82-7431		Vent pipe—battery	1	
3	60-0786	54048008	Rectifier, with nut	1	
4	60-4516	47190	Ballast resistor	1	
5	60-4223	54220	Coil—high tension (6 Volt)	3	
6	60-3923	51320102	Lead—high tension (non-resistive)	3	N. America only
7	60-3924	51320144	Lead—high tension (resistive)	3	Except N. America
8	99-0590	54048288	Zener diode, with washer and nut	1	Type ZD 715
9	97-2237		Heat sink—zener diode	1	
10	97-2275		Plug—heat sink	1	
11	14-1604		Bolt—heat sink fixing ($\frac{1}{4}$ " U.N.F. \times $\frac{7}{8}$ " U.H.)	1	
12	70-1612		Washer, serrated—heat sink bolt	1	
13	60-1935	47637	Condenser pack, Type 2 C.P.	1	
14	60-2068	54190038	Lucar, blade—condenser ground (earth)	1	
15	60-4508	30702	Switch, neutral indicator—type 147SA	1	
16	60-4561		Washer, sealing—neutral indicator switch	1	
18	21-2305		Locknut—neutral indicator switch	1	
18	60-0911	N3	Spark plug	3	
19	60-3043	W.C. 200	Cover—spark plug	3	
20	99-1028	348154	Rear brake switch—type 118 S.A.	1	
21	80-4505		Cover rear brake switch	1	
22	63-5021	70235	Horn 12 Volt—type 6.H.	1	
23	60-4224	33336	Starter relay—type 22 R.A.	1	
24	60-4344		Lead—starter to solenoid	1	
25	60-4345		Lead—solenoid to battery	1	
26	60-4346	54962257	Lead—battery to ground	1	
27	60-4347	54962253	Lead—relay to solenoid	1	
28	60-3719		Oil warning switch (Smiths PS 5330/1/03)	1	
29	06-2828		Cable clip—6" long	11	
30	06-2829		Cable clip—8" long	4	
31	60-4589		Cable clip—10" long	3	

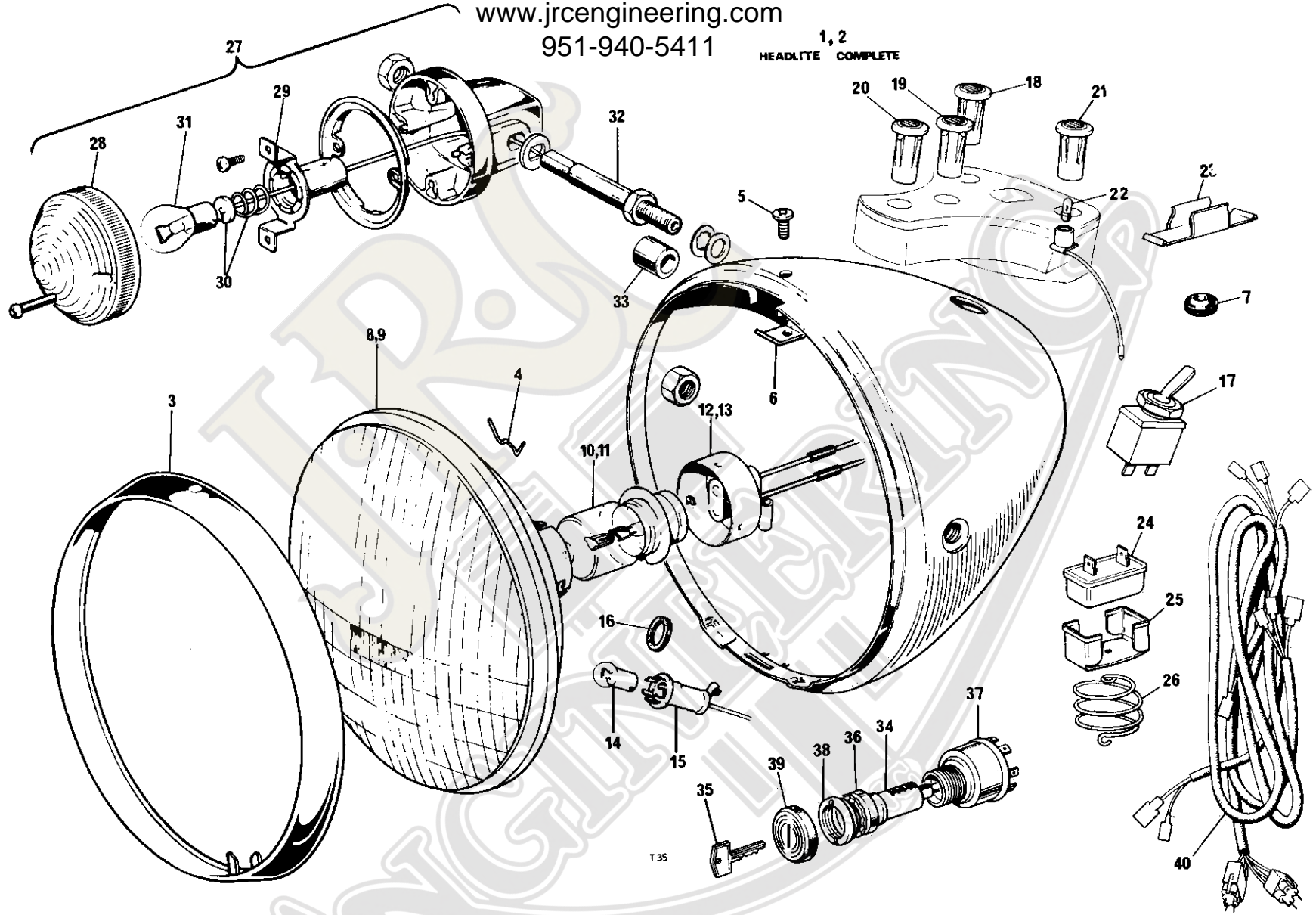

Fig. 38. ELECTRICAL EQUIPMENT—HEADLITE, HARNES, DIRECTION INDICATORS

Ref. No.	Triumph Part No.	Maker's Part No.	DESCRIPTION	QUANTITY	REMARKS
ELECTRICAL EQUIPMENT—HEADLITE, HARNESS, DIRECTION INDICATORS					
1	19-1374	60646A	Headlite, complete—vertical dip	1	N. America & U.K.
2	19-1375	60647A	Headlite, complete—R.H. dip	1	Europe
3	99-0692	553248	Rim,	1	
4	99-0683	504665	Wire—fixing reflector	6	
5		144921	Screw—fixing rim	1	
6		534296	Plate—fixing rim	1	
7		862217	Grommet	2	
8	19-1367	54525927	Light unit—vertical dip	1	N. America & U.K.
9	19-1376	54522680	Light unit—R.H. dip	1	Europe
10	99-1214	370	Bulb,—main—vertical dip	1	N. America & U.K.
11		410	Bulb, main—R.H. dip	1	Europe
12		555319	Bulb holder—vertical dip	1	N. America & U.K.
13		54950493	Bulb holder—R.H. dip	1	Europe
14	99-0548	989	Bulb, pilot	1	
15		54573590	Bulb holder—pilot	1	
16		554354	Ring—pilot bulb holder	1	
17		34660	Switch type 57 S.A.	1	
18	99-1208	54363454	Warning lite—red (assembly)	1	
19	99-1209	54363455	Warning lite—green (assembly)	1	
20	99-1207	54363453	Warning lite—amber (assembly)	1	
21		54361250	Warning lite—blue (assembly)	1	
22	99-0537	281	Bulb—warning lite	4	
23	06-6139		Retaining clip—"A.M.P. plug & socket"	3	
24	99-1201	35048	Flasher unit—Type 8 F.L.	1	
25	60-3521	54385091	Clip—flasher unit	1	
26	60-3614	54386637	Spring—flasher unit	1	
27	06-2041	54057552	Direction indicator lite complete	2	
28	99-1191	54581638	Lens assembly	1	
29		54580322	Bulb holder assembly	1	
30		573832	Interior bulbholder	1	
31	99-1192	382	Bulb	1	
32	19-1368	60600313	Stanchion, c/w nuts & washers	2	
33	97-4125		Distance piece—headlite mounting	2	
34	82-6981	1-6280	Ignition lock—two keys (Wilmot-Breeden)	1	
35			Key—state serial number	1	
36	97-4596		Ignition lock spacer	1	
37	19-1269	39784	Switch—ignition & lites (Type 149 S.A.)	1	
38	97-4589		Nut—for switch	1	
39	60-4335		Rubber cover—for switch	1	
40	60-4559	54962252	Harness—main wiring	1	

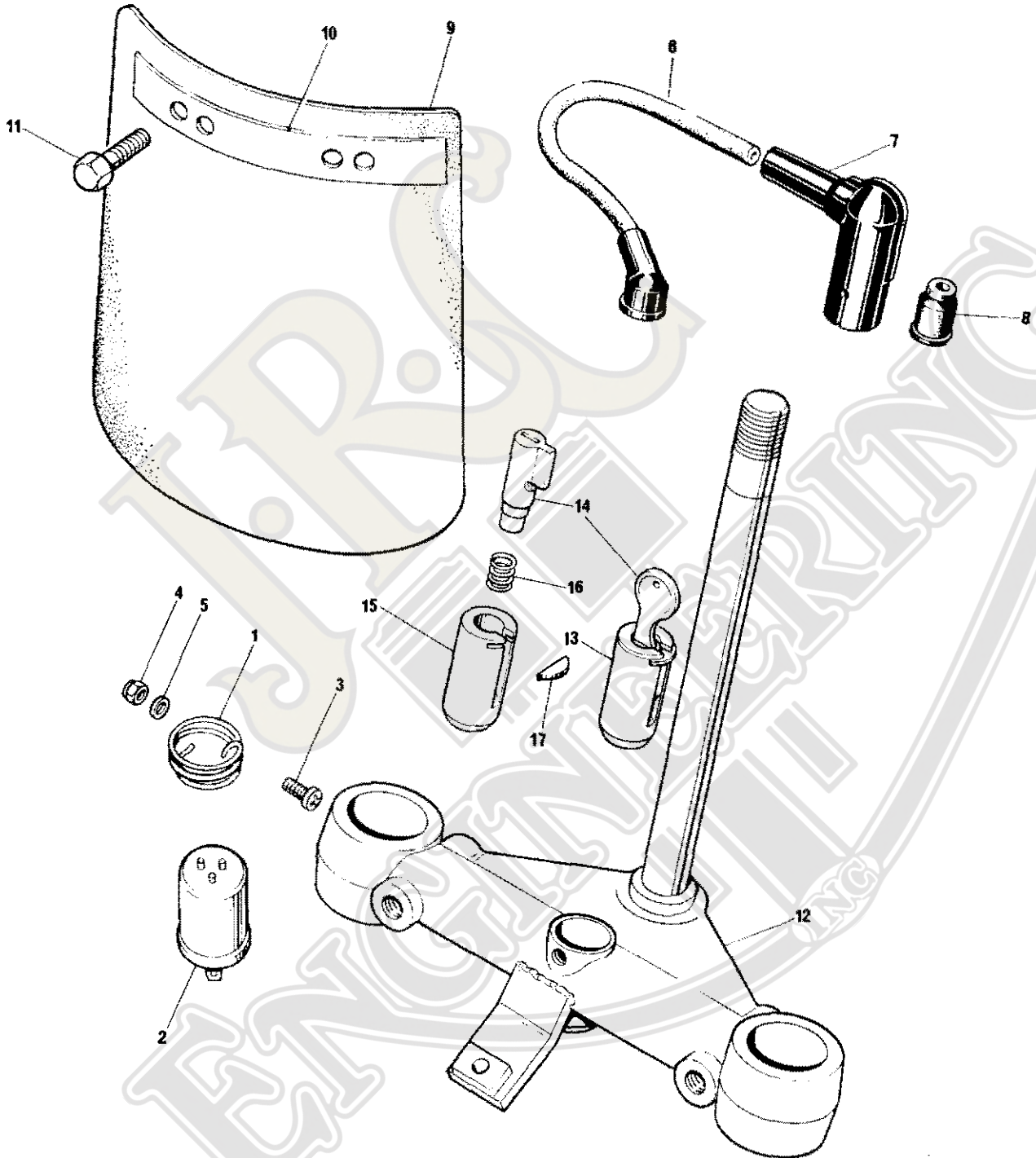

Fig. 39. SPECIAL ITEMS—EUROPE ONLY

Ref. No.	Triumph Part No.	Maker's Part No.	DESCRIPTION	QUANTITY	REMARKS
SPECIAL ITEMS—EUROPE ONLY					
Not illus.	60-3671	LUCAS 411	Headlamp bulb—yellow	1	France
Not illus.	08-3270	Motoplas	Left side rear view mirror	1	
Not illus.	83-3971		Spring—flyback propstand	1	Denmark, Switzerland,
Not illus.	83-3970		Pivot pin—flyback propstand	1	
Not illus.	60-2349		Washer, plain—flyback propstand	1	Sweden
1	60-4317		Spring—flasher unit	1	
2	60-4316	Lucas FL5.35011	Flasher unit	1	
3	21-2079		Screw	1	Germany, Finland
4	21-0778		Nut—self-locking	1	
5	60-2391		Washer—plain	1	
6	60-3893		Ignition lead	3	France, Germany
7	60-3891	Merit— Werk No 1. 10. 51. 10.	Spark plug cap	3	
8	60-3892	Merit— Werk No 1. 05. 05. 57.	Flexible sleeve	3	Switzerland, Sweden
9	83-5736		Rear mudflap	1	France, Italy, Spain, Holland, Belgium, Germany, Finland, Denmark, Switzerland, Sweden
10	83-5737		Backing strip—rear mudflap	1	
11	14-0103		Bolt—rear mudflap	2	
Not illus.	97-5047		Front fork assembly	1	All European continent
12	97-5045		Bottom yoke assembly—Neiman lock	1	
13	60-3780		Lock assembly—Neiman	1	
14	60-3495	M.O. 379	Lock and key (key only B.N. 139)	1	
15	60-3496		Lock housing	1	
16	60-3497		Conical spring	1	
17	60-3498		Key—woodruff...	1	

NUMERICAL INDEX

Part No.	Page	Fig. Ref. No.	Qty	Part No.	Page	Fig. Ref. No.	Qty	Part No.	Page	Fig. Ref. No.	Qty	Part No.	Page	Fig. Ref. No.	Qty
06-1287	47	14	4	14-0402	47	42	1	14-6104	87	11	1	21-1852	27	32	3
06-1287	55	56	4	14-0402	39	31	1	14-6113	17	23	2	21-1872	17	44	1
06-2828	87	29	11	14-0404	47	35	2	14-6114	75	6	2	21-1912	17	8	4
06-2829	87	30	4	14-0702	49	33	1	14-6121	33	15	1	21-1917	33	18	1
06-6139	77	32	1	14-0703	47	40	1	14-6211	21	41	4	21-1930	29	13	2
06-6139	89	23	3	14-1001	77	2	4	14-6218	17	11	2	21-1931	17	2	4
08-3270	91	—	1	14-1019	55	30	2					21-1940	65	8	4
14-0101	31	29	1	14-1022	67	13	1	14-6220	17	12	2	21-1969	51	31	1
14-0101	73	23	4	14-1034	55	14	2	14-6226	17	13	9	21-1978	47	34	2
14-0101	75	3	2	14-1201	75	5	1	14-6504	43	15	2	21-1998	59	5	1
14-0102	75	19	1	14-1201	75	11	3	14-6509	43	16	1	21-2048	79	4	1
14-0102	75	31	1					14-6605	43	25	1	21-2064	67	8	4
14-0102	75	40	2					14-6606	39	8	4	21-2079	71	14	5
14-0102	77	7	4	14-1201	75	26	2	14-6606	41	10	2	21-2079	71	17	1
14-0102	63	45	1	14-1201	75	33	1	14-6606	27	14	6	21-2079	91	3	1
14-0102	63	52	1	14-1201	75	42	2	14-6608	31	14	1	21-2095	55	53	4
14-0103	75	13	2	14-1201	79	5	1	14-6608	31	16	1	21-2102	55	37	4
14-0103	75	23	2	14-1201	53	25	1	14-6609	31	16	1	21-2106	35	8	3
14-0103	91	11	2	14-1201	59	4	1	14-6610	31	15	1	21-2112	51	21	1
14-0103	59	30	2	14-1202	31	38	1	14-6610	39	9	3	21-2140	31	17	1
14-0103	63	16	1	14-1202	31	41	1	14-6610	43	17	1	21-2182	15	4	1
14-0104	75	12	2	14-1202	53	14	2	14-6611	43	18	6	21-2185	15	3	1
14-0106	47	20	2	14-1202	53	17	4	14-6612	27	13	3	21-2189	55	38	2
14-0107	61	20	2	14-1203	63	13	2	14-6612	43	19	1	21-2191	59	3	1
14-0113	75	36	2	14-1301	17	38	6	14-6614	33	19	1	21-2192	59	15	2
14-0113	47	41	1	14-1301	75	20	1	14-6615	43	20	1	21-2194	59	16	2
14-0113	53	7	4	14-1301	77	4	4	14-7002	37	17	2	21-2207	57	18	4
14-0116	53	1	3	14-1301	77	9	4	14-7004	21	5	2	21-2225	77	11	1
14-0120	63	28	1	14-1301	69	12	2	14-7004	21	21	6	21-2243	63	22	2
14-0121	63	29	1	14-1302	29	19	6	14-7005	29	38	6	21-2244	49	18	1
14-0128	51	13	2	14-1302	31	19	1	14-7006	41	9	7				
14-0128	53	37	2	14-1302	37	21	2	14-7008	37	18	1	21-2300	47	30	2
14-0132	51	11	2	14-1302	71	9	1	14-7018	37	19	1	21-2305	87	18	1
14-0201	43	29	1	14-1302	75	38	2	14-7026	17	34	1	21-2309	19	3	3
14-0202	21	20	4	14-1302	49	16	1	14-7101	33	17	1	21-2310	19	4	1
14-0208	27	23	1	14-1302	49	19	1	14-7804	77	17	1	21-2312	31	13	2
14-0213	71	22	2	14-1302	51	9	4	14-7805	43	24	4	21-2315	55	5	1
14-0217	53	34	2	14-1302	53	2	3	14-7806	31	12	1	21-2318	31	25	1
14-0219	29	17	1	14-1302	53	36	2					21-2326	69	30	2
14-0219	53	12	2	14-1302	63	30	2	14-7806	43	23	1	21-2330	63	12	2
14-0219	53	15	4	14-1303	79	31	2	19-1368	89	32	2	21-2332	63	36	2
14-0221	51	8	2	14-1303	47	6	1	19-1369	77	38	2	21-2333	63	38	2
14-0222	21	46	4	14-1303	47	18	2	19-2711	23	28	1	21-2335	59	44	2
14-0223	71	8	1					19-2834	23	25	1	21-2335	63	55	2
14-0223	51	7	2					21-0536	41	14	1	21-2336	53	23	1
14-0234	51	15	2	14-1303	49	29	4	21-0544	31	18	1	21-2341	21	48	1
14-0234	55	15	1	14-1303	51	14	2	21-0545	49	10	1	37-0653	57	14	1
14-0235	49	28	4	14-1303	51	16	2	21-0547	15	28	3	37-0653	61	12	1
				14-1303	55	9	2	21-0547	31	7	4	37-1237	57	13	2
				14-1303	55	16	1	21-0550	69	43	2	37-2294	57	8	40
				14-1303	59	41	2	21-0567	43	2	1	37-2294	61	7	40
				14-1303	63	19	1	21-0582	37	20	2	37-3468	61	36	2
				14-1304	31	26	1	21-0585	45	27	1	37-3761	33	13	1
				14-1304	47	11	2	21-0588	47	7	2	37-3969	57	21	—
				14-1304	51	19	1	21-0589	79	25	2	37-3969	61	34	—
				14-1304	51	22	1	21-0594	35	31	1	37-3970	57	22	—
				14-1307	61	17	1	21-0602	49	9	1	37-3970	61	35	—
				14-1401	21	19	4	21-0678	17	35	1	37-4126	57	4	1
				14-1427	17	20	2	21-0681	39	23	1	37-4127	57	5	1
				14-1619	29	18	5	21-0692	25	7	10	37-4129	57	3	1
				14-1901	47	21	2	21-0762	85	26	3	37-4131	57	6	20
				14-1903	57	20	4	21-0778	71	15	6				
				14-1903	61	23	4	21-0778	91	4	1				
				14-1904	45	17	1	21-1805	47	26	1				
				14-2204	75	9	3	21-1813	17	21	2				
				14-2220	49	32	1	21-1819	41	12	1				
				14-6101	41	19	2	21-1820	41	11	1				
				14-6102	39	34	2	21-1822	75	29	2				
				14-6104	85	22	4	21-1822	69	15	1				

Part No.	Page	Fig. Ref. No.	Qty	Part No.	Page	Fig. Ref. No.	Qty	Part No.	Page	Fig. Ref. No.	Qty	Part No.	Page	Fig. Ref. No.	Qty
37-4141	57	1	1	57-2330	31	31	1	57-4698	33	21	1	60-0990	87	20	1
37-4206	61	8	1	57-2331	47	32	1	57-4699	31	37	1	60-1816	75	44	1
37-4208	61	9	1	57-2450	43	30	1	57-4700	31	5	1	60-1841	49	3	1
37-4209	61	26	1	57-2465	39	26	1	57-4702	31	10	1	60-1907	83	3	1
37-4213	61	30	1	57-2473	39	32	2	57-4704	31	44	1	60-1910	83	7	1
37-4214	61	11	1	57-2478	45	10	1	57-4753	31	11	1	60-1935	87	13	1
37-4215	61	33	1	57-2480	45	9	1	57-4768	33	2	1	60-1959	23	6	1
37-4217	61	15	1	57-2552	39	25	1	57-4771	33	20	1	60-1960	23	7	1
37-4236	61	14	2	57-2553	39	30	1	57-4781	35	9	1	60-1978	81	6	1
37-4243	61	3	1	57-2580	39	22	1	57-4783	35	1	1	60-1987	23	9	1
37-4244	61	6	10	57-3638	39	33	2	57-4793	35	18	1				
37-4252	61	1	1	57-3642	39	5	1	57-4861	31	28	1				
37-4254	61	2	1	57-3642	41	3	1	57-4874	39	6	1	60-1990	65	6	2
37-4259	61	19	1	57-3643	41	4	1	57-4875	39	7	1	60-2061	81	5	3
37-4261	61	16	1	57-3643	43	10	1	57-4876	39	4	1	60-2068	87	14	1
37-4263	59	43	1	57-3644	45	11	1					60-2087	73	25	1
37-4263	63	54	1	57-3646	45	8	1					60-2184	83	5	1
37-4270	61	5	10	57-3647	39	29	1	57-4878	31	21	1	60-2242	79	3	1
37-4272	61	22	4	57-3705	39	19	1	57-4879	31	2	1	60-2294	49	23	2
37-4275	57	17	1	57-3709	39	15	1	57-4881	33	22	1	60-2314	39	27	3
37-4275	61	10	1					57-4889	33	34	1	60-2320	17	39	6
37-4303	57	7	20					57-4890	33	1	1	60-2320	75	21	2
37-4303	61	4	20	57-3715	39	16	1	57-4891	31	1	1	60-2320	47	22	4
37-4305	57	2	1	57-3717	39	17	1	57-4892	31	33	1	60-2321	21	50	1
37-4362	61	27	1	57-3718	39	18	1	57-4895	45	1	1	60-2321	31	39	1
				57-3719	39	20	12	57-4900	35	17	1	60-2321	31	42	1
				57-3720	39	21	6	57-4904	31	23	1	60-2321	71	10	1
				57-3730	39	14	3	57-4906	31	24	1	60-2322	47	19	4
				57-3733	43	4	1	57-4909	35	3	1	60-2322	63	20	1
53-5896	53	32	2	57-3756	39	10	1	57-4911	43	21	1	60-2323	47	10	2
57-0023	31	4	1	57-3757	43	28	1	57-4913	43	22	1	60-2323	51	12	2
57-0031	31	34	1	57-3940	45	6	6	57-4916	39	35	1	60-2323	51	20	2
57-0047	31	6	1	57-3941	45	7	3	57-4917	45	2	1	60-2327	85	23	4
57-0280	57	15	1	57-3978	33	33	2	57-4920	45	3	1	60-2329	77	3	4
57-0280	61	13	1	57-3989	33	38	1	57-4923	43	31	1	60-2330	17	15	7
57-0404	33	26	2	57-3990	43	3	1	57-4926	31	40	1	60-2330	29	22	1
57-0405	33	25	2	57-4004	45	5	1	57-4927	41	16	1	60-2330	29	28	1
57-0407	33	27	1	57-4113	33	8	1	57-4928	41	17	1	60-2330	37	22	2
57-0730	35	26	1	57-4226	33	30	1	57-4929	41	20	1	60-2330	53	3	6
57-0731	35	27	1	57-4227	33	32	1	57-4930	41	18	1	60-2330	63	31	4
57-0825	37	26	1	57-4356	31	32	1	57-4932	41	5	1	60-2331	55	17	1
57-0912	17	19	1	57-4363	33	10	1	57-4933	39	28	1	60-2331	59	42	2
57-0912	33	5	1	57-4364	33	35	1	57-4937	45	14	1				
57-0912	43	12	1	57-4366	33	36	1	57-4941	31	22	1	60-2332	51	23	1
57-0989	17	17	2	57-4370	35	12	1	57-4978	43	9	1	60-2339	49	20	1
57-0989	17	48	2	57-4376	35	13	1	57-4979	43	32	1	60-2340	85	19	4
57-0989	33	9	2	57-4377	35	14	1	57-5000	33	6	1	60-2340	63	14	2
57-0989	43	14	2	57-4394	35	5	1					60-2347	75	41	4
57-1070	57	11	1	57-4396	35	2	1	57-5001	45	4	12	60-2347	77	8	4
57-1070	61	31	1	57-4403	33	24	2	57-5086	33	39	1	60-2347	77	13	1
57-1250	35	28	1	57-4459	33	31	1	57-5087	33	40	1	60-2349	91	—	1
57-1606	17	46	1	57-4575	35	15	1	57-5089	31	36	1	60-2370	19	9	1
57-1607	17	47	1					57-5114	31	35	1	60-2381	73	26	1
57-1607	33	4	1	57-4596	45	13	1	57-5118	41	1	1	60-2391	29	26	2
57-1614	33	3	1	57-4647	35	19	1	57-5119	41	2	1	60-2391	71	16	6
57-1645	43	1	1	57-4653	35	16	1	57-5120	43	7	1	60-2391	73	10	2
57-1646	43	6	1	57-4654	35	22	1	57-5121	43	8	1	60-2391	91	5	1
57-1896	33	11	1	57-4657	35	20	1	60-0052	73	2	1	60-2391	69	32	2
57-1920	17	28	1	57-4660	33	37	1	60-0291	83	2	1	60-2416	69	31	2
				57-4661	35	25	1	60-0494	85	12	1	60-2417	31	30	1
57-1955	31	9	1	57-4662	35	21	1	60-0696	73	13	1	60-2418	47	27	1
57-1956	31	8	1	57-4663	35	23	1	60-0697	73	14	4	60-2420	51	30	1
57-1962	35	30	1	57-4667	39	2	1	60-0702	69	25	6	60-2427	75	14	4
57-1962	43	34	1	57-4673	39	1	1	60-0707	29	32	6	60-2427	59	31	2
57-1963	35	29	1	57-4674	39	3	1	60-0767	83	4	1	60-2427	63	46	1
57-2166	21	17	4	57-4675	39	11	1	60-0786	87	3	1	60-2427	63	53	1
57-2166	43	26	1	57-4677	39	12	1	60-0911	87	18	3	60-2428	75	7	2
57-2215	43	11	1	57-4678	39	13	1	60-0987	87	8	1	60-2428	55	40	4
57-2220	43	5	1												
57-2240	35	32	1												

NUMERICAL INDEX—contd.

Part No.	Page	Fig. Ref. No.	Qty	Part No.	Page	Fig. Ref. No.	Qty	Part No.	Page	Fig. Ref. No.	Qty	Part No.	Page	Fig. Ref. No.	Qty
0-2440	49	17	1	60-4246	47	5	1	60-4456	85	10	1	70-2728	53	24	2
0-2440	49	21	1	60-4246	49	30	8	60-4457	81	2	1	70-3446	33	16	1
0-2604	89	24	1	60-4246	51	17	6	60-4458	81	1	1	70-3448	47	23	2
0-2684	29	29	1	60-4247	17	14	8	60-4460	79	11	1	70-3768	53	11	4
0-2708	33	12	2	60-4247	27	33	3	60-4502	85	25	1	70-3768	53	16	8
				60-4247	29	20	6	60-4503	85	27	3	70-3975	15	5	1
				60-4247	31	20	2	60-4504	41	7	1	70-4144	27	36	1
0-2720	73	18	1	60-4247	75	37	2	60-4505	87	21	1	70-4568	27	8	1
0-3043	87	19	3	60-4247	41	13	2	60-4508	87	15	1	70-4746	25	15	4
0-3161	73	5	1	60-4247	51	10	8	60-4511	67	16	1	70-4752	25	14	8
0-3297	45	29	1	60-4247	53	8	4	60-4512	67	17	1	70-5155	85	31	1
0-3355	85	37	2	60-4247	53	13	2	60-4513	85	7	1	70-5156	85	32	1
0-3494	35	24	1	60-4247	53	18	4	60-4514	85	1	1	70-5157	85	33	1
0-3495	91	14	1	60-4248	69	13	2	60-4515	85	2	1	70-5874	53	10	2
0-3496	91	15	1	60-4250	15	30	3	60-4516	87	4	1	70-5998	15	9	6
0-3497	91	16	1	60-4250	73	24	4	60-4518	59	21	1	70-6018	21	23	2
0-3498	91	17	1	60-4250	77	12	1	60-4520	47	12	1	70-6023	17	31	4
0-3500	35	11	1	60-4251	47	8	2	60-4521	29	39	1	70-6025	17	41	2
0-3510	35	6	1	60-4253	39	24	1	60-4531	83	8	1	70-6026	17	43	2
0-3511	35	10	2	60-4256	29	16	2	60-4539	83	9	1	70-6088	15	22	1
0-3521	89	25	1	60-4259	53	38	2	60-4556	75	43	1				
0-3548	21	24	2	60-4260	75	30	2	60-4559	89	40	1				
0-3552	33	7	1	60-4260	69	16	1	60-4561	87	16	1	70-6130	19	17	1
0-3565	81	3	1	60-4262	69	4	1	60-4569	73	6	1	70-6173	15	26	1
0-3566	81	4	1	60-4266	59	46	1	60-4569	69	35	1	70-6420	21	2	6
0-3585	79	6	1	60-4266	63	11	1					70-6432	27	1	1
0-3586	79	7	1	60-4267	31	27	1					70-6496	25	5	1
0-3614	89	26	1	60-4267	51	29	1	60-4571	23	1	1	70-6501	19	13	1
0-3671	91	—	1	60-4307	45	12	1	60-4572	23	1	1	70-6519	27	9	1
0-3711	83	6	1	60-4315	23	10	1	60-4572	23	1	1	70-6521	27	20	3
0-3719	87	28	1					60-4573	23	37	1	70-6522	27	31	3
0-3748	31	43	1					60-4574	67	5	—	70-6523	15	19	2
0-3761	15	8	6	60-4316	91	2	1	60-4575	67	6	—	70-6524	15	25	1
0-3780	91	13	1	60-4317	91	1	1	60-4578	77	30	1	70-6559	27	21	3
0-3891	91	7	3	60-4328	59	7	1	60-4580	63	34	2	70-6563	21	39	1
0-3892	91	8	3	60-4328	63	49	1	60-4581	63	35	2	70-6564	21	38	1
0-3893	91	6	3	60-4333	31	3	1	60-4583	27	25	1	70-6567	19	10	1
				60-4333	41	6	1	60-4584	63	37	2	70-6570	19	6	2
				60-4335	89	39	1	60-4586	79	8	1	70-6571	19	16	1
0-3896	29	15	2	60-4336	73	7	1	60-4587	79	9	1	70-6573	17	6	1
0-3923	87	6	3	60-4338	59	25	1	60-4589	87	31	3	70-6577	15	2	1
0-3924	87	7	3	60-4341	77	31	1	60-4592	37	24	1	70-6578	17	18	1
0-4101	59	32	1	60-4344	87	24	1	60-4594	47	13	1	70-6580	19	15	1
0-4101	63	2	1	60-4345	87	25	1	60-4595	55	55	1	70-6584	19	11	1
0-4102	59	1	1	60-4346	87	26	1	60-4596	29	30	1	70-6595	19	7	1
0-4103	77	21	2	60-4347	87	27	1	60-4597	63	47	1	70-6743	53	26	1
0-4109	77	25	1	60-4362	81	7	1	70-0402	41	15	1	70-6744	53	28	2
0-4110	77	23	1	60-4365	63	51	1	70-1335	69	42	4	70-6836	15	13	3
0-4156	59	45	1	60-4366	63	50	1	70-1523	17	33	1	70-6838	15	11	6
0-4156	63	56	1	60-4374	63	42	1	70-1523	33	41	1	70-6840	15	14	6
0-4175	59	23	1	60-4393	29	23	1	70-1532	17	5	1	70-6848	69	41	4
0-4177	59	22	1	60-4397	63	40	1	70-1532	25	4	4	70-6848	69	21	2
0-4178	59	26	1	60-4398	63	43	1	70-1558	15	17	2				
0-4180	59	27	3	60-4399	63	44	1	70-1574	21	35	6				
0-4180	63	25	1	60-4401	63	27	1	70-1575	21	36	12	70-6885	45	22	1
0-4182	59	17	1	60-4403	61	29	1	70-1580	15	24	1	70-7246	45	21	1
0-4183	59	18	1	60-4409	63	33	1	70-1591	17	40	1	70-7248	45	20	1
0-4184	59	19	1	60-4414	63	23	1					70-7351	85	38	1
0-4186	59	20	1	60-4415	63	24	1					70-7351	67	18	2
0-4212	37	23	1	60-4419	17	10	3	70-1612	33	29	4	70-7512	53	39	2
0-4217	87	1	1	60-4427	69	34	1	70-1612	77	18	1	70-7573	59	14	1
0-4223	87	5	3	60-4433	71	24	2	70-1612	87	12	1	70-8038	45	24	1
0-4224	87	23	1					70-1670	19	8	1	70-8144	15	32	1
0-4241	37	1	1					70-1719	73	17	1	70-8147	27	35	1
0-4245	21	25	4	60-4438	83	1	1	70-2288	59	28	3	70-8163	27	24	1
0-4245	21	42	4	60-4442	43	13	1	70-2288	63	26	1	70-8175	21	37	6
0-4245	75	4	2	60-4447	43	33	1	70-2351	51	4	2	70-8720	21	11	6
0-4245	75	10	3	60-4454	81	8	1	70-2351	65	12	2	70-8732	19	5	4
0-4245	75	25	2	60-4455	85	6	1	70-2728	37	28	1	70-8738	17	3	2

NUMERICAL INDEX—contd.

Part No.	Page	Fig. Ref. No.	Qty	Part No.	Page	Fig. Ref. No.	Qty	Part No.	Page	Fig. Ref. No.	Qty	Part No.	Page	Fig. Ref. No.	Qty
70-8745	17	22	4	71-1441	27	10	1	71-4138	85	28	1	82-7510	69	11	2
70-8751	17	4	2	71-1442	19	2	1	71-4139	85	29	1	82-7560	73	15	1
70-8755	17	32	1	71-1444	19	14	2	71-4181	69	37	1	82-7835	71	25	1
70-8756	27	22	2	71-1445	21	40	2	71-4182	69	38	1	82-7835	73	22	2
70-8760	27	29	1	71-1447	33	14	1	71-4185	69	39	2	82-7848	49	8	2
70-8762	27	2	1	71-1451	35	7	1					82-7862	73	21	1
70-8764	15	16	1	71-1454	43	35	—					82-8026	73	20	1
70-8768	15	23	1	71-2246	15	20	1	71-4237	19	20	1	82-8090	49	7	2
70-8770	25	8	10	71-2248	15	21	1	71-4237	45	30	1	82-8243	51	32	1
70-8770	57	19	8	71-2250	15	27	1	71-4245	21	15	1	82-8245	71	12	1
70-8770	61	24	4					71-4246	21	14	1	82-8382	47	38	1
70-8773	21	16	2					71-4250	25	6	1	82-8981	37	30	1
70-8774	17	16	4	71-2480	85	36	1	71-4251	45	15	1	82-9033	53	31	2
70-8776	17	24	2	71-2501	49	4	1	71-4252	45	19	1	82-9054	53	33	2
70-8780	15	31	1	71-2653	85	34	1	71-4356	21	1	1	82-9089	53	35	2
				71-2660	45	25	1	71-4358	21	4	1	82-9092	63	32	2
				71-2718	15	18	2	71-4360	29	9	1	82-9279	51	33	1
				71-2792	19	12	1	71-4378	25	12	4	82-9317	65	9	2
70-8780	17	42	1	71-3208	17	25	2	71-4400	29	3	1	82-9321	65	14	4
70-8782	21	18	4	71-3221	45	16	1	71-4402	53	6	2	82-9322	65	13	8
70-8782	43	27	1	71-3222	45	18	1	71-4407	53	9	1	82-9323	65	10	2
70-8785	45	28	1	71-3294	29	11	1	71-4424	53	19	1	82-9353	71	4	1
70-8787	21	9	6	71-3307	15	1	1	71-4427	53	20	1	82-9435	69	7	1
70-8788	21	10	6	71-3358	21	33	6	71-4429	53	21	1	82-9436	67	15	1
70-8789	21	12	6	71-3361	21	7	3	71-4431	53	22	1	82-9445	73	4	1
70-8817	25	3	12	71-3362	21	8	3	71-4433	17	7	1	82-9530	69	26	1
70-8819	21	44	2	71-3541	45	26	1	71-4434	27	4	1	82-9531	69	27	1
70-8820	21	43	4	71-3579	37	10	1	71-4435	27	28	—	82-9561	71	6	3
70-8860	53	27	2	71-3581	37	11	1	71-4458	53	40	2	82-9562	71	20	3
70-8896	17	45	1	71-3587	21	29	2	71-4459	53	29	1	82-9573	65	7	4
70-8904	69	20	1	71-3588	21	28	2	82-1335	79	26	2				
70-8914	25	2	3	71-3589	21	31	1	82-1713	69	6	1				
70-9060	29	31	3	71-3590	21	30	1	82-2184	55	10	3	82-9630	51	34	1
70-9073	29	2	2	71-3596	15	15	1	82-3808	75	18	1	82-9659	69	2	1
70-9073	29	5	2	71-3641	17	1	1	82-4129	73	8	2	82-9664	69	9	1
70-9237	21	26	4	71-3653	37	15	1	82-4129	69	36	2	82-9907	65	5	2
70-9239	21	27	4	71-3654	37	16	1	82-4228	73	16	1	82-9997	49	13	1
70-9240	21	45	8	71-3655	37	31	1					83-0002	67	19	2
70-9254	29	12	1	71-3661	37	32	1	82-4671	47	33	1	83-1267	47	31	1
70-9255	29	7	2	71-3662	37	33	1	82-4715	27	11	3	83-1270	47	36	2
70-9266	27	6	3	71-3663	37	29	1	82-4715	55	43	2	83-1549	69	33	1
70-9332	85	30	1	71-3664	37	27	1	82-4717	29	25	2	83-1598	51	6	2
70-9510	21	3	2					82-4717	73	9	2	83-2175	71	3	1
70-9558	21	22	2	71-3665	37	25	1	82-4717	65	11	2	83-2266	61	18	1
70-9586	71	21	3	71-3748	21	13	12	82-4898	73	19	2	83-2726	77	1	1
70-9727	15	7	6	71-3785	69	22	1	82-5313	49	6	1	83-3665	29	14	1
70-9739	15	12	3	71-3786	69	23	1	82-5343	69	3	1	83-3875	67	9	1
70-9740	15	6	3	71-3885	29	8	1	82-5943	51	27	4	83-3970	91	—	1
				71-3919	29	4	1	82-5944	49	11	1	83-3971	91	—	1
70-9741	15	10	3	71-3935	25	1	1	82-5994	75	35	1	83-4774	77	10	1
70-9807	27	30	1	71-3946	29	33	1	82-6031	75	34	1	83-4784	77	5	1
70-9856	17	26	2	71-3947	29	36	6	82-6039	69	17	1	83-4800	77	19	2
71-0007	27	5	2	71-3948	29	37	3	82-6042	49	2	2	83-4806	77	20	1
71-0037	33	23	1	71-3974	25	11	6	82-6310	75	24	2	83-4968	75	28	1
71-0070	21	32	6	71-3976	25	10	6	82-6310	75	32	1	83-4984	69	1	1
71-0245	29	6	2	71-3987	41	8	1	82-6673	71	7	2	83-4985	71	1	1
71-1051	45	23	1	71-4001	29	34	1	82-6673	71	11	1	83-5001	77	16	1
71-1070	17	27	2	71-4002	29	35	1	82-6673	73	3	2	83-5014	71	13	1
71-1070	19	19	1	71-4045	61	25	4	82-6673	69	10	2	83-5015	69	28	1
71-1070	35	4	1	71-4077	29	1	1	82-6738	55	3	1	83-5021	87	22	1
71-1129	17	30	4	71-4078	29	21	1	82-6821	49	5	2	83-5092	71	19	1
71-1175	69	40	2	71-4082	29	10	1	82-6850	77	6	1	83-5096	71	18	1
71-1190	25	13	4	71-4084	29	27	1	82-6874	69	8	1				
71-1270	19	18	1	71-4098	21	6	8	82-6915	75	22	1	83-5105	77	15	2
71-1349	17	37	6	71-4098	25	9	4	82-6981	89	34	1	83-5147	75	39	1
71-1350	27	7	1	71-4099	29	24	1	82-7021	47	39	1	83-5168	71	26	1
71-1351	19	1	1	71-4122	17	9	2	82-7352	49	12	1	83-5168	75	27	1
71-1353	19	22	1	71-4131	85	35	1	82-7431	87	2	1	83-5230	63	1	1
71-1440	27	3	1												

NUMERICAL INDEX—contd.

Part No.	Page	Fig. Ref. No.	Qty	Part No.	Page	Fig. Ref. No.	Qty	Part No.	Page	Fig. Ref. No.	Qty	Part No.	Page	Fig. Ref. No.	Qty
83-5231	49	14	1	83-5864	65	2	1	97-4377	55	35	1	99-0512	23	18	1
83-5237	49	31	1	83-5869	65	4	1	97-4380	55	19	2	99-0513	23	19	1
83-5270	51	1	1	83-5870	61	28	1	97-4387	55	20	2	99-0514	23	20	1
83-5276	69	14	1	83-5874	75	16	1	97-4391	79	10	1	99-0515	23	12	1
83-5309	73	11	1					97-4391	59	2	1	99-0517	23	24	1
83-5353	47	29	2					97-4399	55	33	1	99-0520	23	13	1
83-5361	67	7	2	83-5890	69	18	1	97-4456	55	41	1	99-0521	23	4	4
83-5362	69	29	1	83-5891	69	19	1	97-4457	55	42	1	99-0522	23	2	1
83-5366	63	21	1	83-5892	69	5	1	97-4461	55	54	2	99-0537	89	22	4
83-5368	49	1	1	83-5895	53	30	2	97-4476	55	7	1	99-0542	77	29	1
83-5378	73	12	1	83-5897	47	1	1	97-4541	55	11	1	99-0683	89	4	6
83-5388	51	3	2	83-5898	47	2	1	97-4545	55	34	1	99-0692	89	3	1
83-5390	69	24	1	83-5899	47	15	1	97-4552	75	2	1	99-0769	27	17	3
83-5393	67	1	—	83-5900	47	16	1	97-4554	55	24	2	99-1014	27	16	1
83-5401	63	18	1	97-0430	27	12	3	97-4556	55	23	2	99-1015	27	18	1
83-5423	47	24	1	97-0745	23	11	1	97-4557	55	46	1	99-1016	27	27	1
83-5424	47	25	1	97-0961	77	22	2					99-1020	23	15	1
83-5434	71	23	1	97-1425	79	23	4	97-4558	55	47	1	99-1021	23	26	1
83-5465	63	39	1	97-1527	79	24	2	97-4566	55	2	1	99-1022	23	30	1
83-5466	63	41	1	97-1529	79	27	4	97-4573	85	13	2	99-1023	23	31	1
83-5467	63	48	1	97-1580	79	29	2	97-4574	85	14	1	99-1034	23	14	1
83-5473	51	2	1	97-1581	79	30	2	97-4577	85	15	1	99-1035	23	16	1
83-5474	75	17	1	97-1708	59	24	1	97-4579	85	21	1	99-1049	23	3	1
83-5477	51	26	1	97-2123	21	47	4	97-4583	79	2	1	99-1051	23	32	1
83-5485	71	5	1	97-2123	27	34	6	97-4587	85	20	2	99-1139	49	26	2
				97-2125	79	20	1	97-4588	85	17	4	99-1152	23	33	1
				97-2142	79	21	1	97-4589	89	38	1	99-1153	23	34	1
				97-2208	55	50	2	97-4596	89	36	1				
83-5486	71	2	1	97-2209	55	51	4	97-4600	55	21	2	99-1191	77	34	1
83-5529	37	34	1	97-2210	55	52	4	97-4605	55	1	1	99-1191	89	28	1
83-5548	51	5	2	97-2221	79	28	2	97-4651	79	1	1	99-1192	77	37	1
83-5549	49	15	1	97-2237	87	9	1	97-5000	85	24	1	99-1192	89	31	1
83-5550	49	22	1	97-2266	55	6	1	97-5045	91	12	1	99-1207	89	20	1
83-5581	51	25	1	97-2275	87	10	1	97-5047	91	—	1	99-1208	89	18	1
83-5583	37	35	1	97-2291	79	22	2	97-5053	75	1	1	99-1209	89	19	1
83-5610	67	14	1	97-3893	55	44	2	97-5055	75	15	1	99-1214	89	10	1
83-5616	67	12	2					97-5056	55	48	1	99-1233	27	15	1
83-5617	67	10	1	97-4001	55	36	1	97-5057	55	49	1	99-1257	77	26	1
83-5618	67	11	1	97-4002	55	45	2	97-5058	75	8	1	99-2751	59	6	1
83-5690	73	1	1	97-4003	55	27	2	97-5061	85	16	2	99-2752	59	8	1
83-5704	63	15	1	97-4004	55	31	2	99-0107	49	25	4	99-2754	59	9	1
83-5736	91	9	1	97-4009	55	29	2	99-0122	49	24	4	99-2757	59	10	1
83-5737	91	10	1	97-4010	55	25	2	99-0173	85	11	1	99-2758	59	11	1
83-5806	67	2	—	97-4020	55	26	2	99-0224	23	29	1	99-2760	59	12	1
83-5813	47	3	1	97-4028	55	13	1	99-0225	79	18	2	99-2762	59	13	1
83-5845	51	24	1	97-4031	55	12	2					99-2765	59	36	2
83-5847	67	4	—	97-4076	55	22	2					99-2765	63	6	2
83-5848	67	3	—	97-4112	81	9	6					99-2766	59	37	2
83-5853	53	4	1	97-4125	89	33	2	99-0438	23	23	1	99-2766	63	7	2
83-5854	53	5	1	97-4244	55	28	2	99-0510	23	8	1	99-2767	59	38	4
83-5857	47	37	1	97-4317	55	18	1	99-0511	23	22	1	99-2767	63	8	2
83-5860	65	3	2												
83-5863	65	1	1												
83-5864	65	2	1												