

1967

TRIUMPH

REPLACEMENT PARTS CATALOGUE

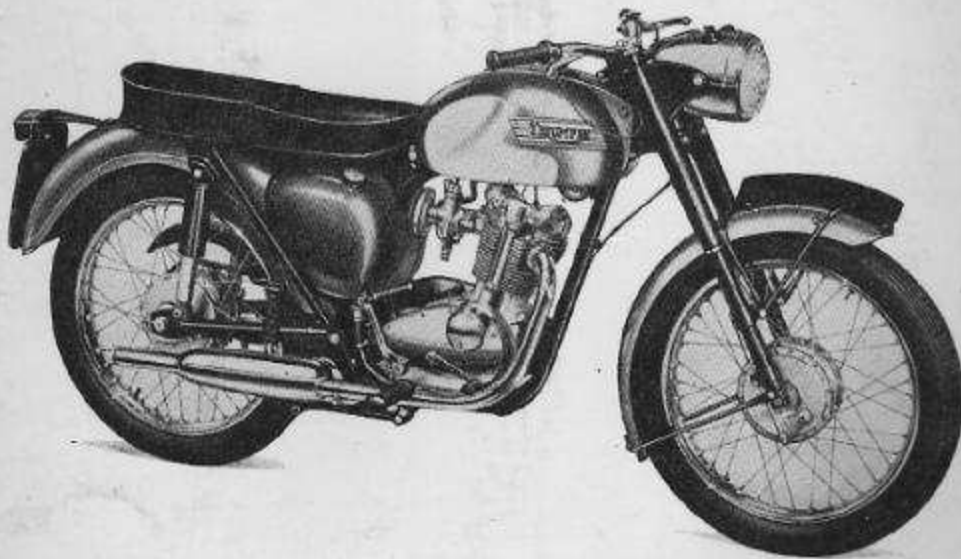

BANTAM CUB 200 c.c.

SUPER CUB 200 c.c.



REPLACEMENT PARTS CATALOGUE

TIGER CUB MODELS

BANTAM CUB

SUPER CUB

TRIUMPH ENGINEERING COMPANY LIMITED
MERIDEN WORKS · ALLESLEY · COVENTRY · ENGLAND
TELEPHONE MERIDEN 331 TELEGRAMS "TRUSTY, COVENTRY"

TRIUMPH GUARANTEE

1. In this Guarantee the word "machine" refers to the motor cycle, scooter, motor cycle combination or sidecar as the case may be, purchased by the Purchaser.
2. In order to obtain the benefit of this Guarantee, the Purchaser must have correctly completed the registration form and returned it to us within fourteen days of the purchase.
3. We will supply, free of charge, a new part in exchange for, or, if we consider repair sufficient, will repair free of charge any part proved within six months of the date of purchase of any new machine, (three months overseas) or within three months of its renewal or repair in the case of a part already renewed or repaired, to be defective by reason of our faulty workmanship or materials. We do not undertake to bear the cost of fitting such new or repaired part or accessory.
4. Any part considered to be defective must be sent to our Works, carriage paid, accompanied by the following information:—
 - (a) Name of purchaser and his address;
 - (b) Date of purchase of machine;
 - (c) Name of dealer from whom the purchase was made;
 - (d) Engine number and model.
5. This Guarantee shall not extend to defects or damage appearing after misuse, neglect, abnormal stress or strain, or the incorporation or affixing of unsuitable attachments or parts and in particular:—
 - (a) Hiring out;
 - (b) Racing and Competitions;
 - (c) Adaptation or alteration of any part or parts after leaving our Works;
 - (d) The attaching of a sidecar in a manner not approved by us or to an unsuitable motor cycle.

This Guarantee shall not extend to machines whose trade mark, name or manufacturing number has been altered or removed, or in which has been used any part not supplied or approved by us, or to tyres, saddles, chains, speedometers, revolution counters and electrical equipment or to parts supplied to the order of the Purchaser and different from our standard specification.
6. Our liability and that of our dealer who sells the machine, shall be limited to that set out in this guarantee, and no other claims including claims for consequential damage or injury to person or property, shall be admissible. All other conditions and warranties statutory or otherwise and whether express or implied are hereby excluded and no guarantee other than that expressly herein contained applies to the machine to which this Guarantee relates or any accessory or part thereof.
7. We reserve the right to modify or deviate from the Published Specification without notice.

REPAIRS GUARANTEE

1. Whilst the highest standard of workmanship and materials is aimed at, we cannot accept liability for any defects appearing more than three months after the machine, assembly or component has left our Works after being repaired.
2. We will repair or replace at our option free of charge any defective work, materials or parts relating to the repairs carried out by us appearing within that time but shall not be under any further or other liability for any other loss or damage whether direct or consequential and our liability shall be limited to the cost of so making good. We do not undertake to bear the cost of fitting any replacement or repaired part.
3. We do not accept liability in respect of parts of proprietary manufacture, e.g. tyres, saddles, chains, speedometers, revolution counters and electrical equipment which may be used by us in effecting a repair. All other conditions and warranties statutory or otherwise express or implied are hereby excluded.

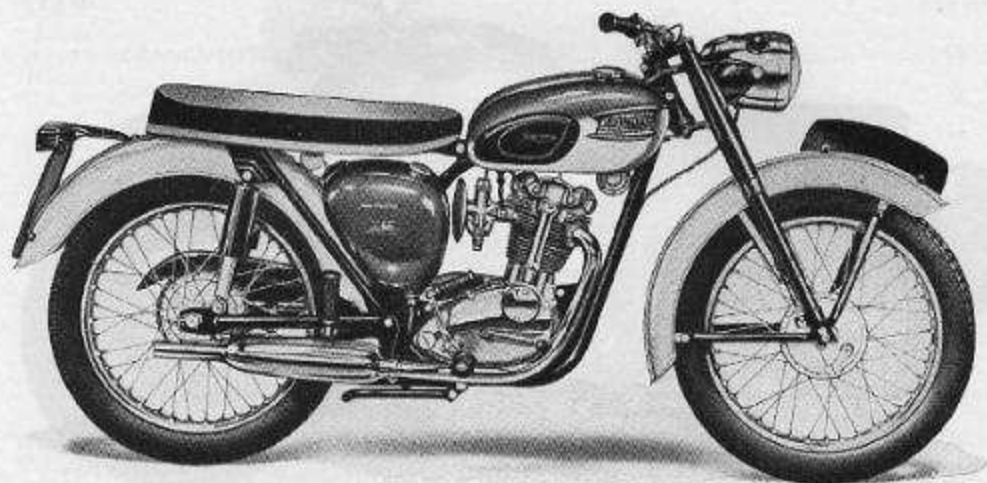

BANTAM CUB TECHNICAL DATA

Bore and stroke	63 x 64 mm. 2.480 x 2.520 ins.
Capacity	199 c.c. (12 cu. ins.)
Compression ratio	7 : 1
Sparking plug	Champion L7
Carburetter	Amal Monobloc
			Choke size	$\frac{1}{8}$ in.
			Main jet	90
			Needle jet105T
			Needle	Type B
			Throttle valve	$375/3\frac{1}{2}$
			Pilot jet	25
Gearbox sprocket	17 teeth
Final Drive Sprocket	47 teeth
Chains	Front	$\frac{3}{8}$ in. x $\frac{7}{16}$ in. Duplex x 62 links
			Rear	$\frac{1}{2}$ in. x $\frac{3}{16}$ in. x 115 links
Capacities	Fuel tank	2 galls. (9 litres)
			Oil tank	4 pints (2.25 litres)
			Gearbox	$\frac{1}{2}$ pint (190 c.c.)
			Primary chaincase	$\frac{1}{2}$ pint (190 c.c.)
			Front forks (each leg)	$\frac{1}{2}$ pint (75 c.c.)
Brakes	Front and rear diameter	$5\frac{1}{2}$ in. (13.97 cm.)
Tyre size	Front	3.00 x 18
			Rear	3.00 x 18

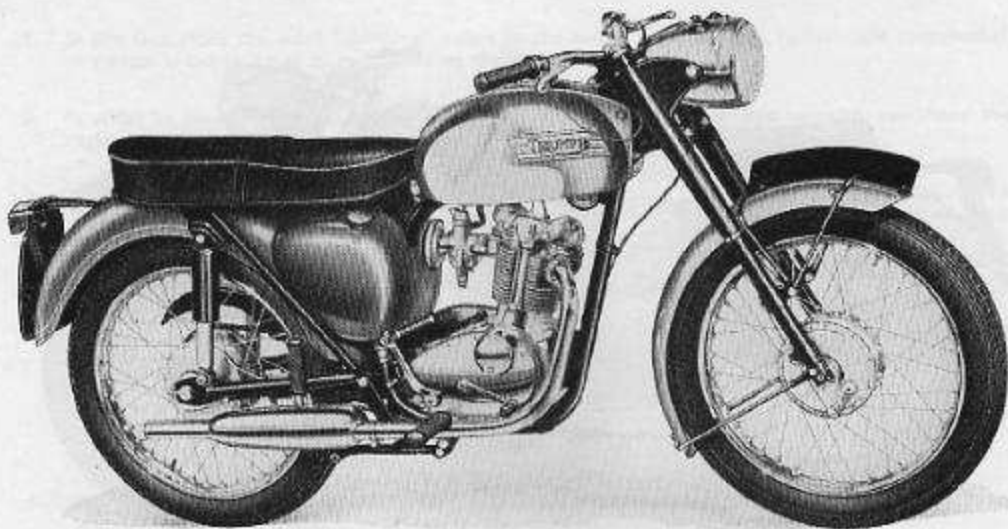

SUPER CUB TECHNICAL DATA

Bore and stroke	63 x 64 mm. 2.480 x 2.520 ins.
Capacity	199 c.c. (12 cu. ins.)
Compression ratio	7 : 1
Sparking plug	Champion L7
Carburetter	Amal Monobloc
	Choke size $\frac{3}{8}$ in.
	Main jet 90
	Needle jet .105T
	Needle Type B
	Throttle valve $376/3\frac{1}{2}$
	Pilot jet 25
Gearbox sprocket	17 teeth
Final Drive Sprocket	47 teeth
Chains	Front $\frac{3}{8}$ in. x $\frac{1}{2}$ in. Duplex x 62 links
	Rear $\frac{1}{2}$ in. x $\frac{1}{2}$ in. x 115 links
Capacities	Fuel tank 3 galls. (13.5 litres)
	Oil tank 4 pints (2.25 litres)
	Gearbox $\frac{1}{2}$ pint (190 c.c.)
	Primary chaincase $\frac{1}{2}$ pint (190 c.c.)
	Front forks (each leg) $\frac{1}{8}$ pint (75 c.c.)
Brakes	Front and rear diameter $5\frac{1}{2}$ in. (13.97 cm.)
Tyre size	Front 3.00 x 18
	Rear 3.00 x 18

ILLUSTRATION INDEX

Fig No.	Page No.
1	10
2	12
3	14
4	16
5	18
6	20
7	22
8	24
9	26
10	28
11	30
12	32
13	34
14	36
15	38
16	40
17	42
18	44
19	46
20	48
21	50
22	52
23	54
24	56
25	58
26	60

INDEX

	<i>Page</i>		<i>Page</i>
AIR FILTER	47	MUDGUARDS AND NUMBER PLATES	37, 39
BATTERY CARRIER	47	OIL PUMP	17
CARBURETTER	53	OIL TANK	43, 45
CARTON PACKS	9	PETROL TANK	43, 45
CENTRE STAND	23	PILLION FOOTRESTS	25
CHAINGUARDS	25	PISTONS	11
CHAINS	21	PROP STAND	25
CLUTCH	21	REAR WHEEL	33, 35
COIL	57	RECTIFIER	55
CONTACT BREAKER	57	ROTOR	11
CONTROL CABLES	51	SILENCER	41
CONTROL LEVERS	49	SPARKING PLUG	57
CRANKCASE	13	SPEEDOMETER	61
CRANKSHAFT	11	STATOR	59
CYLINDER BARREL AND HEAD ...	15	STEERING RACES	23, 27
ELECTRICAL EQUIPMENT	55, 57, 59	SUSPENSION UNITS	23
ENGINE BOLTS	23	SWITCHES	55
ENGINE SPROCKET	11	TIMING GEARS	11
EXHAUST PIPE	41	TOOLBOX AND TOOLKIT	47
FOOTRESTS	25	TWINSEAT	41
FRAME	23	TWISTGRIP	49
FRONT FORK	27	VALVES	15
FRONT WHEEL	29, 31	WIRING HARNESS	55
GASKET SETS	9		
GEARBOX	19		
HANDLEBAR	49		
HORN	55		

TRIUMPH SPARES

HOW TO ORDER. Every part is indicated by number, and this should be quoted together with the description. In order to assist customers, dimensions have been given in many cases where parts are similar. Parts where possible have been listed in order of assembly and a number of the illustrations show the assembly order also. With these aids there should be no difficulty in identifying the parts you require. **Always head your order with the engine number, stamped on the front engine lug, together with the prefix letters.**

WHERE TO OBTAIN. Triumph Spare Parts can only be obtained from an authorised Triumph Dealer, and we recommend our customers to place their orders with the Triumph Dealer in their district. When parts not usually asked for are required, and for which the Dealer may have to write or obtain specially, the postage or carriage incurred becomes payable.

Triumph Spares are not supplied to private owners direct from the factory. A list of authorised dealers who stock Triumph spares is available from the factory. If difficulty is experienced in obtaining the required parts, the matter should be taken up directly with the Triumph Spares Department.

Customers are warned against the risk incurred by purchasing parts that are not of genuine Triumph manufacture. This risk is eliminated if parts are ordered as instructed from recognised Dealers.

PATTERNS AND PARTS FOR REPAIR. It is not necessary to send patterns if the part number is quoted. The sending of patterns often delays the order as parcel post or rail takes longer than letter post.

Parts sent to Coventry for repair, replacement, or as patterns should bear the sender's name and address and clear instructions should accompany the parts. In your own interest send a copy of the advice note under separate cover. All parts must be forwarded carriage paid and care should be taken to ensure that all remittances are sent separately and not enclosed with the parts. Fragile units such as cylinders, etc., should always be boxed to avoid damage in transit. Complete machines should have all fittings such as windscreens, driving mirrors, tools, etc., removed by the sender before despatch, as it is impossible for us to accept responsibility in the event of loss in transit. We are always pleased to give estimates for overhauling and repairs, but should an estimate not be accepted, a charge will be made covering cost of dismantling and re-assembling, if carried out.

Communications relating to Parts should be addressed to the SPARES DEPARTMENT and for repairs, guarantee claims and technical advice to the SERVICE DEPARTMENT, Triumph Engineering Co. Ltd., Meriden Works, Allesley, Coventry. In order to facilitate quick reference, the quoting of any number, invoice number or reference from previous communications is essential. Accessories not of our manufacture should be sent direct to the actual makers, whose names and addresses appear below.

PROPRIETARY GROUP

Ancillary equipment which is fitted to our motor cycles is of the highest quality and is guaranteed by the manufacturers and not by ourselves. Any repairs or claims should be directed to the actual makers or their local agents who will always give owners every possible assistance. The following are the addresses of the various manufacturers:—

CARBURETTERS.

Messrs. Amal Ltd.,
Holdford Road, Witton, Birmingham, 6.

CHAINS.

Renold Chains Ltd.,
Wythenshawe, Manchester.

ELECTRICAL EQUIPMENT.

Messrs. J. Lucas Ltd.,
Gt. Hampton Street, Birmingham, 18.

TYRES.

Dunlop Rubber Co. Ltd.,
Fort Dunlop,
Birmingham, 24.
The Avon India Rubber Co. Ltd.,
Melksham,
Wiltshire.

SPARKING PLUGS.

Champion Sparking Plug Co. Ltd.,
Feltham, Middlesex.

SPEEDOMETERS.

Messrs. Smiths Industries Ltd.,
Cricklewood Works, London, N.W.2.

SUSPENSION UNITS.

Messrs. Girling Ltd.,
Birmingham Road, West Bromwich, Staffs.

HOW TO USE THIS PARTS CATALOGUE

Consult the indices on Page 5 and 6 for the parts or group of parts which you wish to locate. When you have located the parts on the illustration check the reference number on the facing page and make sure from the end column that the part you have located does apply to your machine.

List the quantities required as single units; do not ask for "2 pairs" or "3 dozen".

In case of painted items always state the colour required. Painted parts are available only in the colours or alternatives specified for that model of that particular year.

<i>Colour</i>	<i>Suffix letter to Part No.</i>
Black	W.
Perrivale Blue	OO
White	O
Firecracker Red	FR

Paint is available also in all colours in 9½ oz. Aerosol cans or 1 gallon tins.

SPECIAL WORKSHOP TOOLS

A COMPLETE LIST OF WORKSHOP TOOLS CAN BE MADE AVAILABLE BY EITHER CONTACTING YOUR DEALER OR APPLYING DIRECT TO THE TRIUMPH SERVICE DEPARTMENT. IN MOST CASES THESE TOOLS ARE VERY COSTLY AS THEY ARE MADE ENTIRELY FOR WORKSHOP USE, AND THEREFORE, IT IS NOT RECOMMENDED THAT THE PRIVATE OWNER PURCHASE THE TOOLS IN ORDER TO AID SERVICING THE MACHINE ONCE OR TWICE ONLY. IN THESE CIRCUMSTANCES IT IS FAR MORE ECONOMICAL TO GET IN TOUCH WITH A RECOGNISED DEALER.

WORKSHOP TOOLS

Z 135	Distributor gear extractor
Z 139	Timing pinion extractor
D 485	Contact breaker extractor
D 486	Contact breaker reassembly pilot
D 400	Clutch extractor
D 538	Flywheel tool
D 526	Crankshaft bearing extractor tool

CARTON PACK LIST

The following sub-assemblies are supplied in carton packs under the C.P. part number stated. The contents of these carton packs are preserved and will not deteriorate under adverse conditions.

Part No.	Contents
Brake linings	
C.P. 128	2 W978 Brake linings
	14 W979 Rivets
Piston	
C.P. 141	1 E3358 Piston, C.R. 7 : 1
	1 E656 Compression ring (plain)
	1 E3048 Compression ring (taper)
	1 E3387 Oil control ring
	1 E1750 Gudgeon pin
	2 E1767 Circlip
Piston rings	
C.P. 150	1 E656 Compression ring (plain)
	1 E3048 Compression ring (taper)
	1 E3387 Oil control ring
Valve guides	
C.P. 122	2 E3208 Valve guide
	2 E3209 Circlip
Valves	
C.P. 186	1 E3963 Inlet valve
	1 E3147 Exhaust valve
Valve springs	
C.P. 123	2 E3214 Inner valve spring
	2 E3215 Outer valve spring
Gasket set	GS T20/59 All models
De-coke gasket set	D/GS 3 All models

PLEASE NOTE

THROUGHOUT THIS LIST, ASSEMBLIES ARE PRINTED IN CAPITALS AND THE COMPONENTS INCLUDED IN THAT ASSEMBLY ARE INDENTED IN THE DESCRIPTION COLUMN. REVERTING TO THE ORIGINAL ALIGNMENT WHEN THE ASSEMBLY IS COMPLETE. TO ORDER THE COMPLETE ASSEMBLY IT IS NECESSARY ONLY TO QUOTE THE ASSEMBLY NUMBER. ANY COMPONENT PARTS LISTED MAY ALSO BE OBTAINED SEPARATELY, IF REQUIRED.

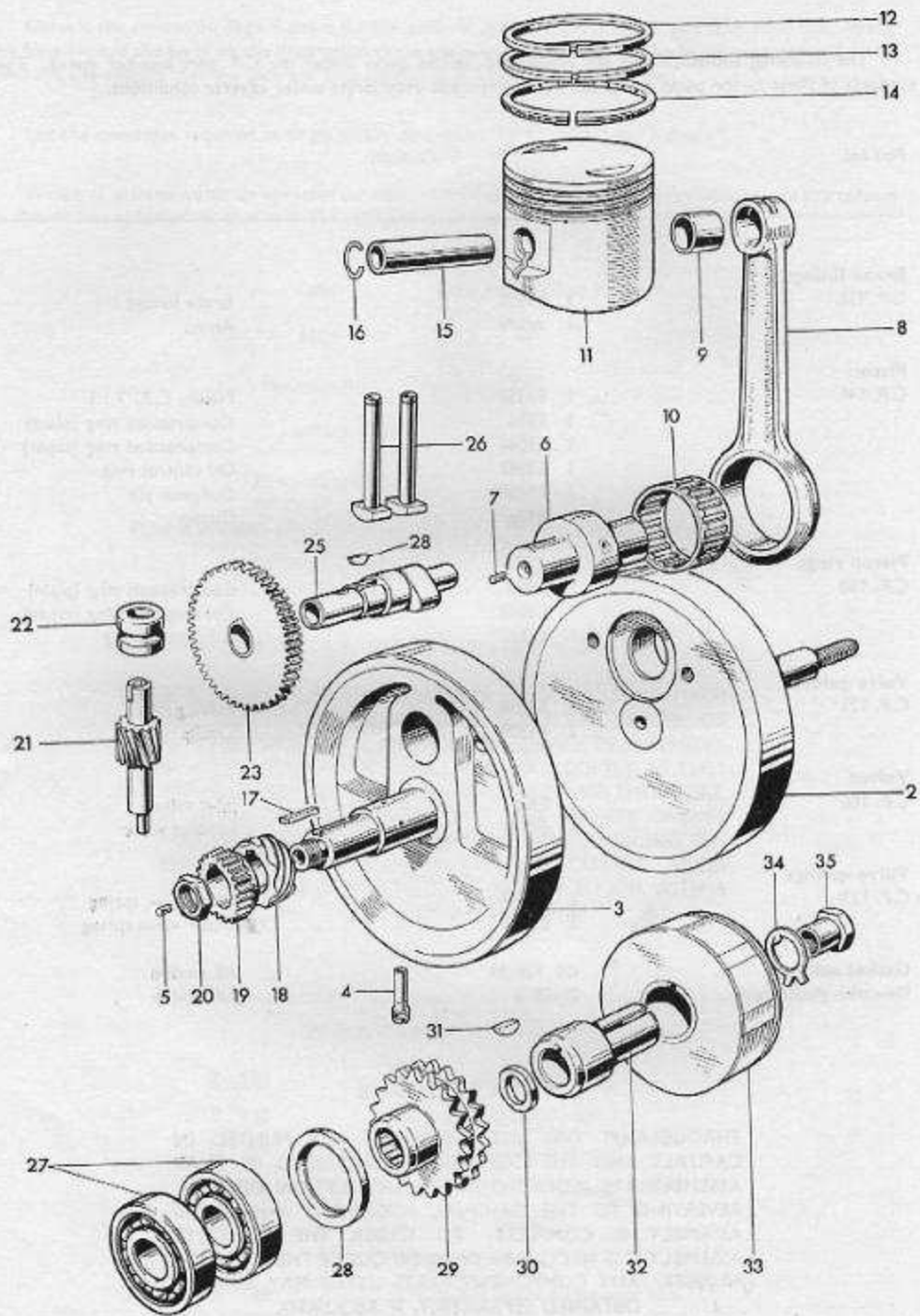

Fig. 1. CRANKSHAFT, PISTON AND TIMING GEARS

CRANKSHAFT, PISTON AND TIMING GEARS

Ref. No.	Part No.	DESCRIPTION	QUANTITY
1	E7507	CRANKSHAFT ASSEMBLY	1
2	E4436	Left flywheel	1
3	F5893	RIGHT FLYWHEEL	1
4	E5806	Screwed plug	1
5	E3902	Oilway plug	1
6	E6539	CRANKPIN	1
7	E3292	Oilway plug	2
8	E7508	CONNECTING ROD	1
9	E1762	Small end bush	1
10	E7509	Needle roller bearing	1
11	CP141	PISTON COMPLETE, C.R. 7 : 1	1
12	E656	Compression ring	1
13	E3048	Taper compression ring	1
14	E3387	Oil control ring	1
15	E1750	Gudgeon pin	1
16	E1767	Circlip	2
17	E4453	Key	1
18	E5260	Distributor drive gear	1
19	E4451	Timing pinion	1
20	F2725	Nut	1
21	E5913	Oil pump drive shaft	1
22	E4693	Oil pump shaft bush...	1
23	E3185	Camshaft pinion	1
24	E3184	Camshaft key	1
25	E6606	Camshaft	1
26	E3285	Tappet	2
27	E3152	Main bearing	2
28	E3379	Oil seal	1
29	E3912	Engine sprocket (19 teeth Duplex)	1
30	E4458	Spacing washer	1
31	E4455	Key	1
32	E4454	Adaptor sleeve	1
33	54213903	Rotor, RM18	1
34	E4058	Tab washer	1
35	E3971	Nut	1

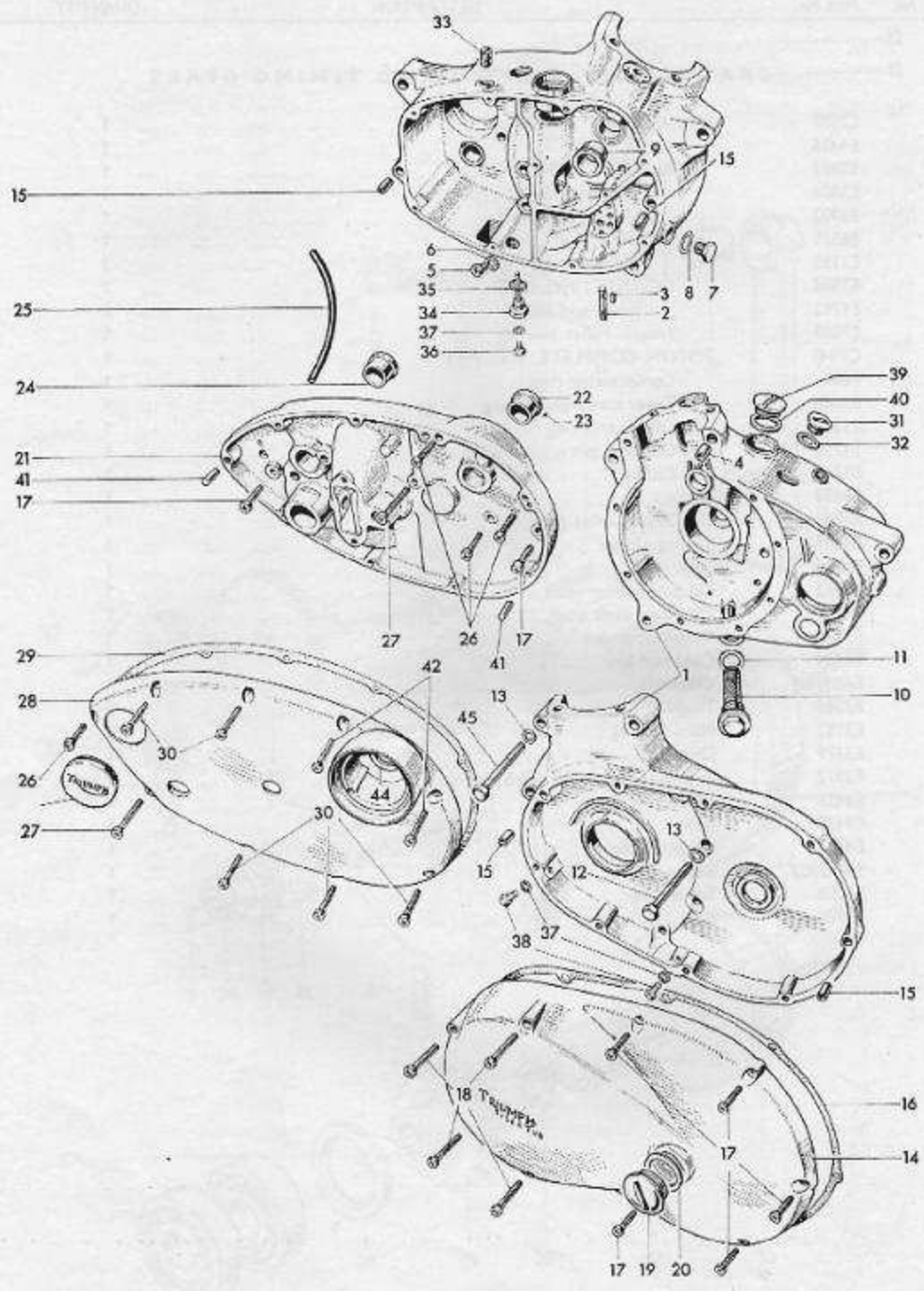

Fig. 2. CRANKCASE

CRANKCASE

Ref. No.	Part No.	DESCRIPTION	QUANTITY
1	75-343	CRANKCASE	1
2	E3171	Oil junction block stud	1
3	E3169	Oil junction block dowel	1
4	E4121	Hollow dowel	1
5	T1553	Screwed plug ($\frac{3}{8}$ in. U.H.)	1
6	E2441	Copper washer	1
7	E2615	Screwed plug	1
8	E1335	Copper washer	1
9	E3175	Camshaft bush	1
10	E5456	Crankcase filter	1
11	E2570	Fibre washer	1
12	E4098	Bolt ($1\frac{1}{8}$ in. U.H.)	7
13	S25-3	Plain washer	9
14	E4089	Left outer cover	1
15	T989	Hollow dowel	4
16	E4871	Joint washer	1
17	E3204	Screw (1 in. U.H.)	7
18	E4096	Screw ($2\frac{1}{8}$ in. U.H.)	4
19	E732	Filler plug	1
20	NE507	Fibre washer	1
21	E4787	RIGHT INNER COVER	1
22	E4666	Camshaft bush	1
23	E3172	Peg	1
24	T1147	Mainshaft bush	1
25	F3775	Breather pipe	1
26	E3220	Screw ($1\frac{1}{8}$ in. U.H.)	4
27	E3221	Screw ($1\frac{1}{8}$ in. U.H.)	2
28	E4637	Right outer cover	1
29	E4872	Joint washer	1
30	E3231	Screw ($1\frac{1}{8}$ in. U.H.)	7
31	T1599	Filler plug	1
32	E1465	Fibre washer	1
33	E4048	Blanking plug...	as required
34	T1112	Drain plug (with level tube)	1
35	T1257	Fibre washer	1
36	T361	Level plug	1
37	WE170	Fibre washer	3
38	DSS7	Screwed plug	2
39	E4587	Blanking plug...	1
40	E4593	Fibre washer	1
41	E4172	Hollow dowel	2
42	E4638	Outer cover screw ($\frac{3}{8}$ in. U.H.)	2
43	H1466	Clutch cable access grommet	1
44	E4568	Oil seal	1
45	E7304	Bolt (2 in. U.H.)	2

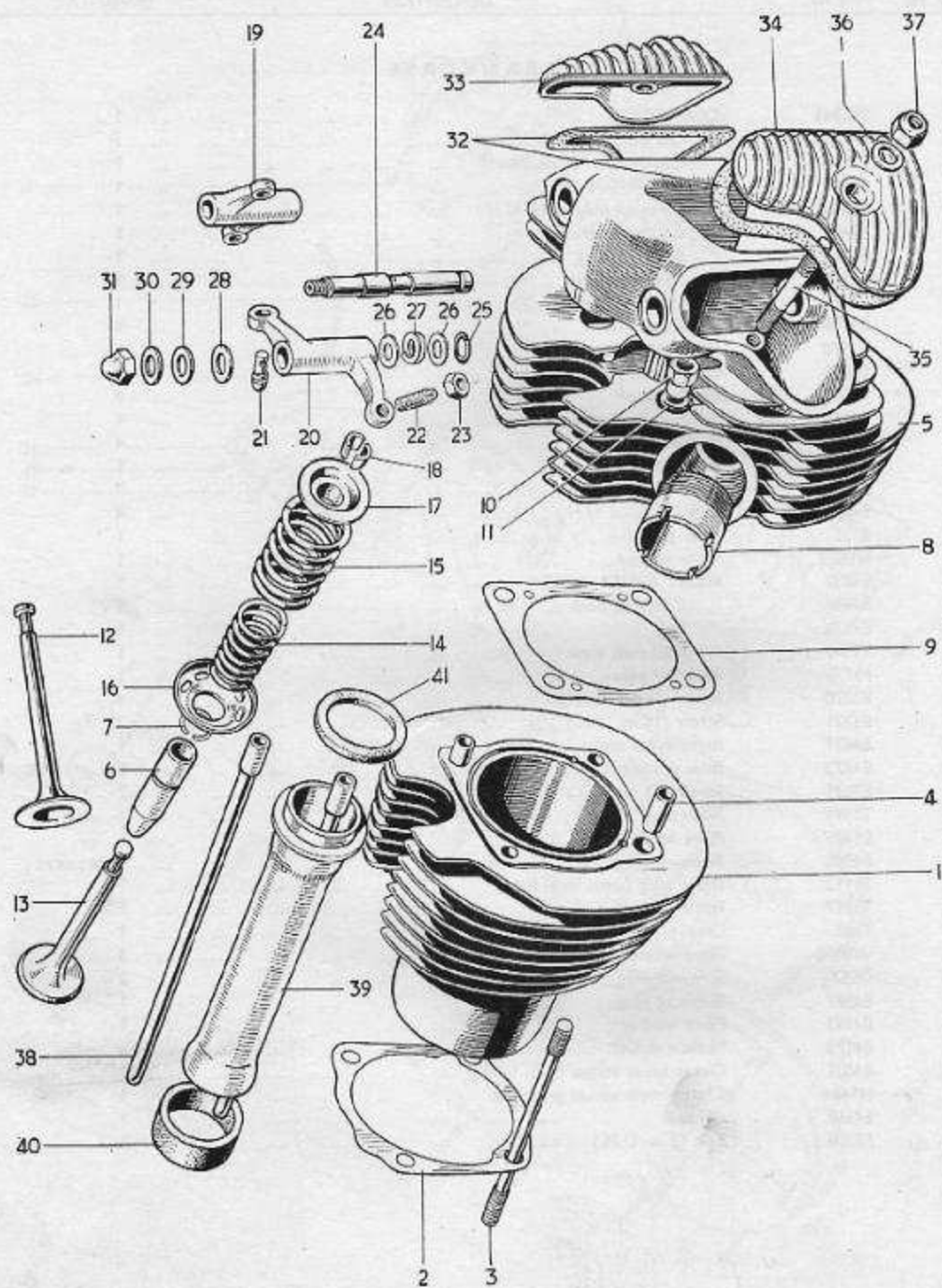
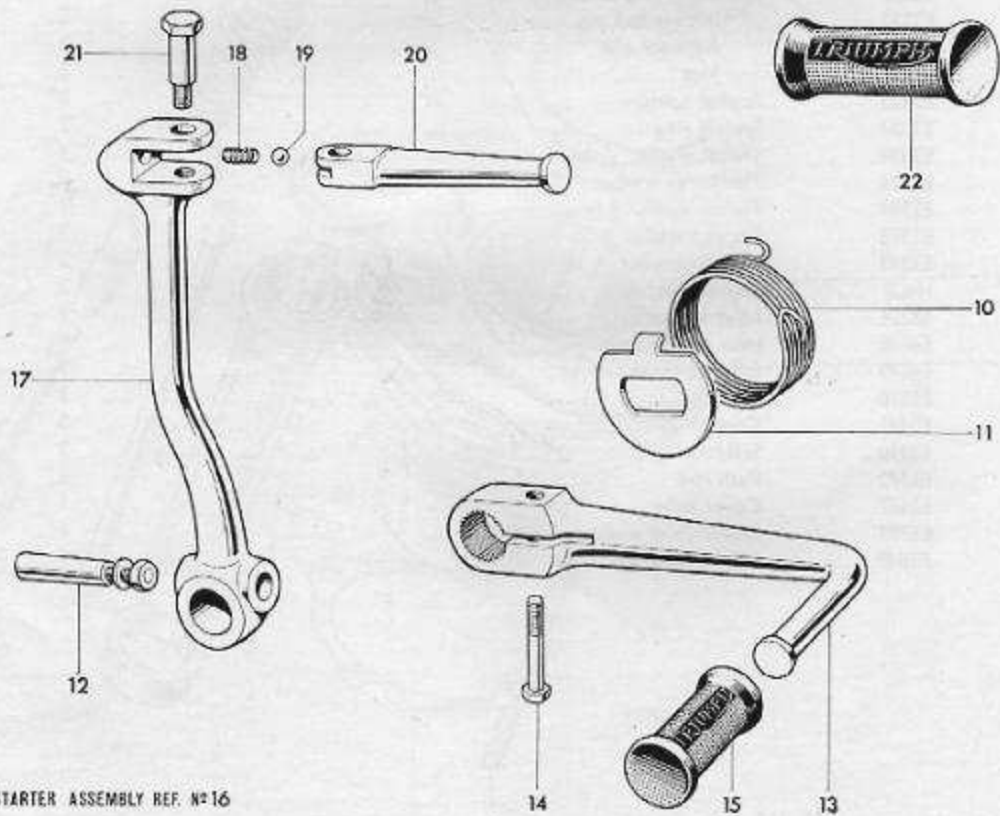
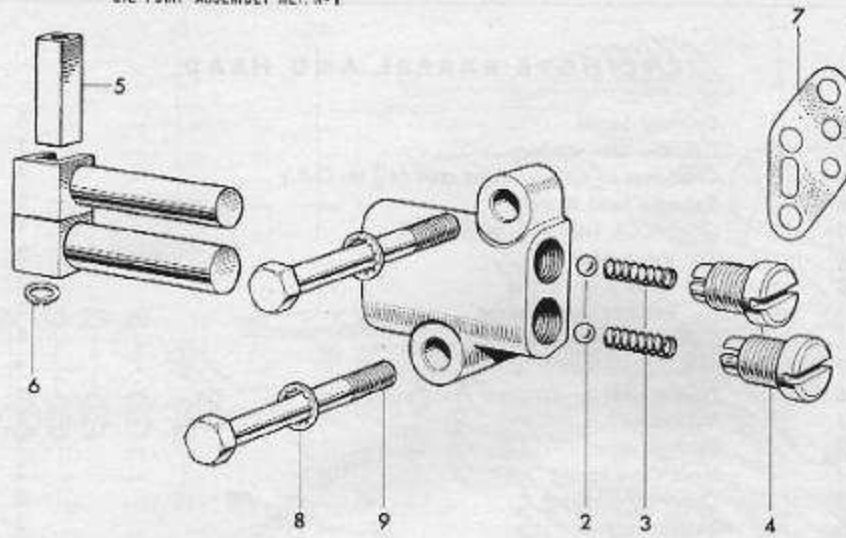

Fig. 3. CYLINDER BARREL AND HEAD

CYLINDER BARREL AND HEAD

Ref. No.	Part No.	Description	Quantity
1	E6094	Cylinder barrel	1
2	E4037	Cylinder base washer	1
3	E3170	Crankcase to cylinder head stud (4 $\frac{13}{32}$ in. O.A.)	4
4	E3386	Cylinder head dowel	2
5	E6093A	CYLINDER HEAD C/W GUIDES	1
6	E3208	Valve guide	2
7	E3209	Valve guide circlip	2
8	E3207	Exhaust pipe adaptor	1
9	E3217	Cylinder head gasket	1
10	E5897	Nut	4
11	E3446	Plain washer	4
12	E3963	Inlet valve	1
13	E3147	Exhaust valve	1
14	E3214	Inner valve spring	2
15	E3215	Outer valve spring	2
16	E3213	Bottom cup	2
17	E3301	Top collar	2
18	WE259A	Split cotter	4
19	E3251	INLET ROCKER	1
20	E3252	EXHAUST ROCKER	1
21	E3222	Rocker ball pin	2
22	E3223	Adjuster pin	2
23	GS662	Nut	2
24	E3225	Rocker spindle	2
25	E3253	Sealing ring	2
26	E2534	Thrust washer $\frac{7}{16}$ in.	4
27	E3224	Thackeray washer	2
28	E2594	Thrust washer $\frac{3}{8}$ in.	2
29	E1335	Copper washer $\frac{3}{8}$ in.	2
30	E3249	Copper washer $\frac{5}{16}$ in.	2
31	H400	Domed nut	2
32	E3226	Joint washer	2
33	E4648	Inlet rocker cover	1
34	E4649	Exhaust rocker cover	1
35	E3210	Stud (2 $\frac{5}{16}$ in. O.A.)	2
36	E2441	Copper washer	2
37	E3290	Self-locking nut	2
38	E3372	Push rod	2
39	E3537	Cover tube	1
40	E3391	Lower joint washer	1
41	E3540	Upper joint washer	1

OIL PUMP ASSEMBLY REF. N°1



KICKSTARTER ASSEMBLY REF. N°16

Fig. 4. OIL PUMP AND CONTROL PEDALS

Ref. No. Part No.

DESCRIPTION

QUANTITY

OIL PUMP AND CONTROL PEDALS

1	E6486	OIL PUMP ASSEMBLY	1
2	S70-4	Steel ball ($\frac{1}{8}$ in. diam.)	2
3	E4404	Spring	2
4	E4212	Plug	2
5	E5912	Drive block	1
6	E6474	Circlip... ..	1
7	E3188	Joint washer	1
8	G5299	Serrated washer	2
9	E3197	Bolt ($\frac{1}{8}$ in. U.H.)	2
10	T1162	Kickstarter return spring	1
11	T1163	Return spring plate	1
12	T1222	Cotter pin c/w nut and washer	1
13	T1164	Gearchange pedal	1
14	F1369	Bolt ($\frac{3}{8}$ in. U.H.)	1
15	T449	Pedal rubber	1
16	T1679	KICKSTARTER ASSEMBLY	1
17	T1680	Crank	1
18	T1167	Spring	1
19	S70-3	Steel ball ($\frac{1}{4}$ in. diam.)	1
20	T2070	Pedal	1
21	T1169	Pivot bolt	1
22	F1814	Pedal rubber	1

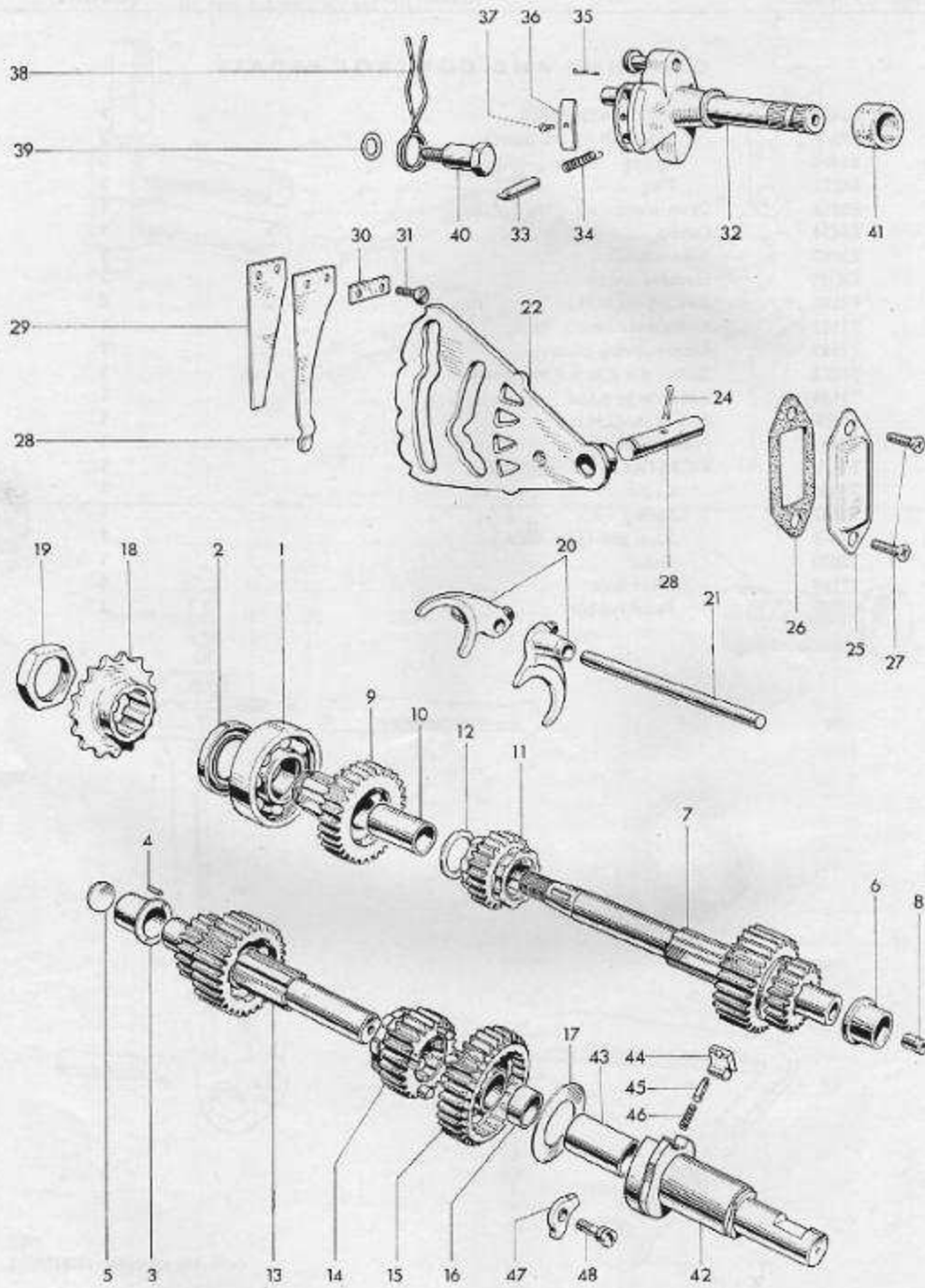

Fig. 5. GEARBOX SHAFTS AND GEARS

GEARBOX SHAFTS AND GEARS

Ref. No.	Part No.	DESCRIPTION	QUANTITY
1	T1070	High gear bearing	1
2	H1168	Oil seal	1
3	T1073	Layshaft bearing bush	1
4	E3172	Peg	1
5	T1269	Blanking disc	1
6	T1147	Mainshaft bush	1
7	T2449	MAINSHAFT CLUSTER	1
8	T1085	Clutch rod bush	1
9	T1565	HIGH GEAR	1
10	T1515	High gear bush	1
11	T1089	Mainshaft second gear	1
12	T1090	Mainshaft thrust ring	1
13	T1591	Layshaft cluster	1
14	T1094	Layshaft third gear	1
15	T2326	LAYSHAFT LOW GEAR	1
16	T1097	Low gear bush	1
17	T1274	Pawl retaining disc	1
18	T1513/17	Gearbox sprocket (17 teeth)	1
19	T1082	Sprocket nut	1
20	T1098	Selector fork	2
21	T1102	Selector fork spindle	1
22	T1066	Camplate	1
23	T1069	Camplate spindle	1
24	$\frac{3}{32}$ in. x $\frac{3}{8}$ in.	Split pin	1
25	T1149	Cover plate	1
26	T1148	Joint washer	1
27	T1150	Screw (0.41 in. U.H.)	2
28	T1248	Index spring	1
29	T1249	Supplementary index spring	1
30	T1180	Lockplate	1
31	T1076	Screw ($\frac{3}{8}$ in. U.H.)	2
32	T2104	GEARCHANGE QUADRANT	1
33	T2105	Plunger	2
34	T2106	Spring	2
35	T1277	Peg	2
36	T2107	Keeper plate	1
37	T2435	Screw ($\frac{1}{4}$ in. U.H.)	1
38	T1109	Return spring	1
39	E2287	Serrated washer	1
40	T1077	Bolt	1
41	T1181	Felt washer	1
42	T1279	KICKSTARTER SPINDLE	1
43	T1118	Bush	1
44	T1281	Pawl	1
45	T1282	Plunger	1
46	T1161	Spring	1
47	T1157	Stop plate	1
48	T1158	Screw	1

OPERATING LEVER ASSEMBLY REF. N° 1
 CLUTCH COMPLETE REF. N° 13

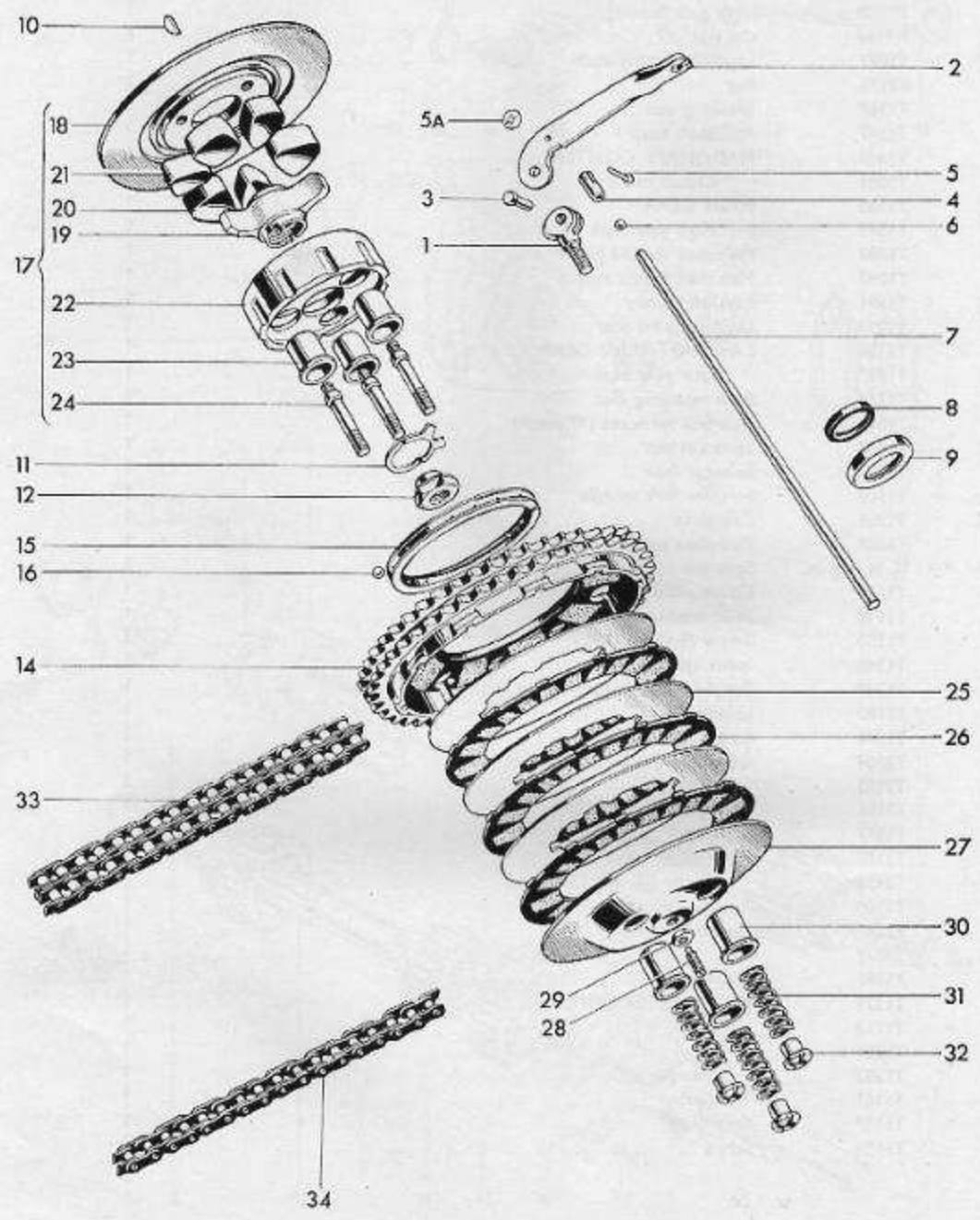

Fig. 6. CLUTCH AND CHAINS

CLUTCH AND CHAINS

Ref. No.	Part No.	DESCRIPTION	QUANTITY
1	T2065	CLUTCH OPERATING LEVER ASSEMBLY	1
2	T2066	Lever	1
3	T1236	Pivot pin	1
4	T2067	Cup	1
5	T2068	Pin	1
5A	T2069	Push fix	1
6	T1124	Steel ball ($\frac{1}{8}$ in. diam.)	1
7	T1140	Clutch operating rod	1
8	E3932	Mainshaft oil seal	1
9	E3933	Oil seal retainer	1
10	T1119	Key	1
11	T1347	Tab washer	1
12	T1348	Nut	1
13	T1924	CLUTCH COMPLETE	1
14	T1509	Sprocket and housing (48 teeth)	1
15	T1264	Bearing ring	1
16	T1124	Steel ball ($\frac{1}{8}$ in. diam.)	16
17	T1667	SHOCK ABSORBER	1
18	T1668	Back plate	1
19	T1346	Spider	1
20	T1132	Drive rubber (large)	3
21	T1318	Rebound rubber (small)	3
22	T1314	Centre	1
23	T1669	Cup	3
24	T1670	Pin	3
25	T1315	Driven plate	3
26	T1503	Driving plate c/w linings	3
27	T1925	Pressure plate	1
28	T2064	Adjuster	1
29	GS662	Nut	1
30	T1927	Cup	3
31	T1742	Spring	3
32	T1146	Nut	3
33	D382	Primary chain ($\frac{1}{8}$ in. Duplex x 62 links)	1
34	D339	Rear chain ($\frac{1}{8}$ in. x $\frac{1}{8}$ in. x 115 links)	1

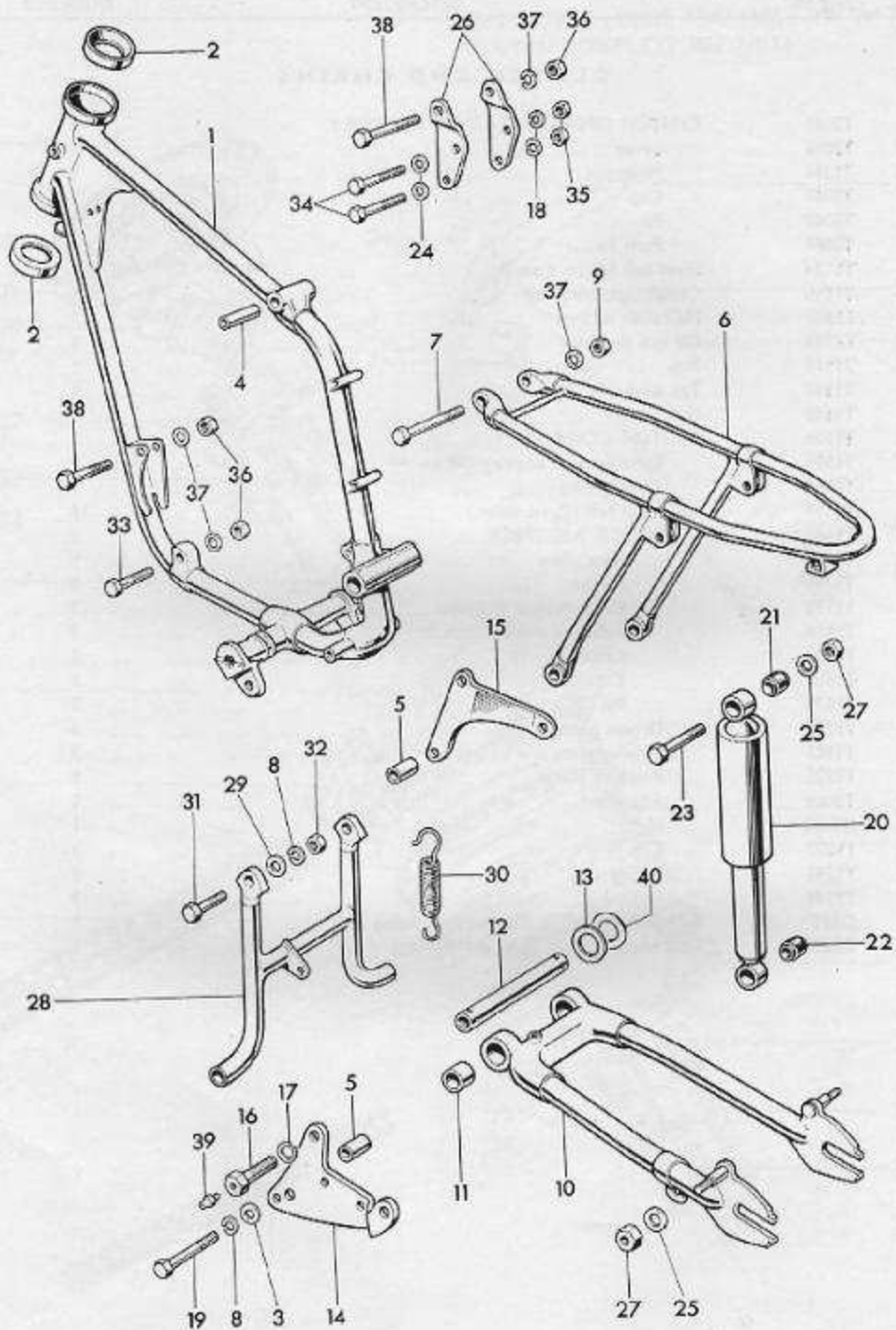

Fig. 7. FRAME COMPLETE

Ref No.	Part No.	DESCRIPTION	QUANTITY
FRAME COMPLETE			
1	75-4125	Front frame	1
2	65-4465	Steering race cup	2
3	75-4128	Plain washer	1
4	90-4297	Hollow dowel	1
5	90-4294	Pillion footrest spacer	2
6	90-4274	Rear frame	1
7	21-5728	Bolt (3/4 in. U.H.)	1
8	2-522	Spring washer	5
9	21-5104	Nut	1
10	†90-4327	SWINGING FORK	1 Super Cub
11	F4076	Pivot bush	2
12	90-4317	Spindle	1
13	F4078	Spacing washer	1
14	75-4854	Left footrest bracket	1
15	75-4852	Right footrest bracket	1
16	40-4249	Hollow bolt (1 1/8 in. U.H.)	2
17	3-110	Spring washer	2
18	24-8784	Spring washer	2
19	21-5724	Bolt (2 1/4 in. U.H.)	2
20	64052983	SUSPENSION UNIT	2
21	9054/316A	Bonded bush	2
22	9054/316J	Bonded bush	2
23	F1760	Bolt (1 1/2 in. U.H.)	2
24	2-923	Plain washer	2
25	S25-2	Plain washer	4
26	75-4124	Rear engine plate	2
27	S1-52	Nut	4
28	90-4729	Centre stand	1
29	15-431	Plain washer	2
30	90-4733	Return spring	1
31	90-4732	Pivot bolt	2
32	2-1813	Nut	2
33	F3191	Bolt (2 1/2 in. U.H.)	1
34	F2596	Bolt (1 1/2 in. U.H.)	2
35	S1-51	Nut	2
36	F3955	Self-locking nut	3
37	2-2138	Plain washer	3
38	F1245	Bolt (1 1/8 in. U.H.)	2
39	64-95	Lubricator	2
40	F4385	Shim, 0.003 in.	as required
40	F4386	Shim, 0.005 in.	as required
	†90-4300	SWINGING FORK	1 Bantam Cub

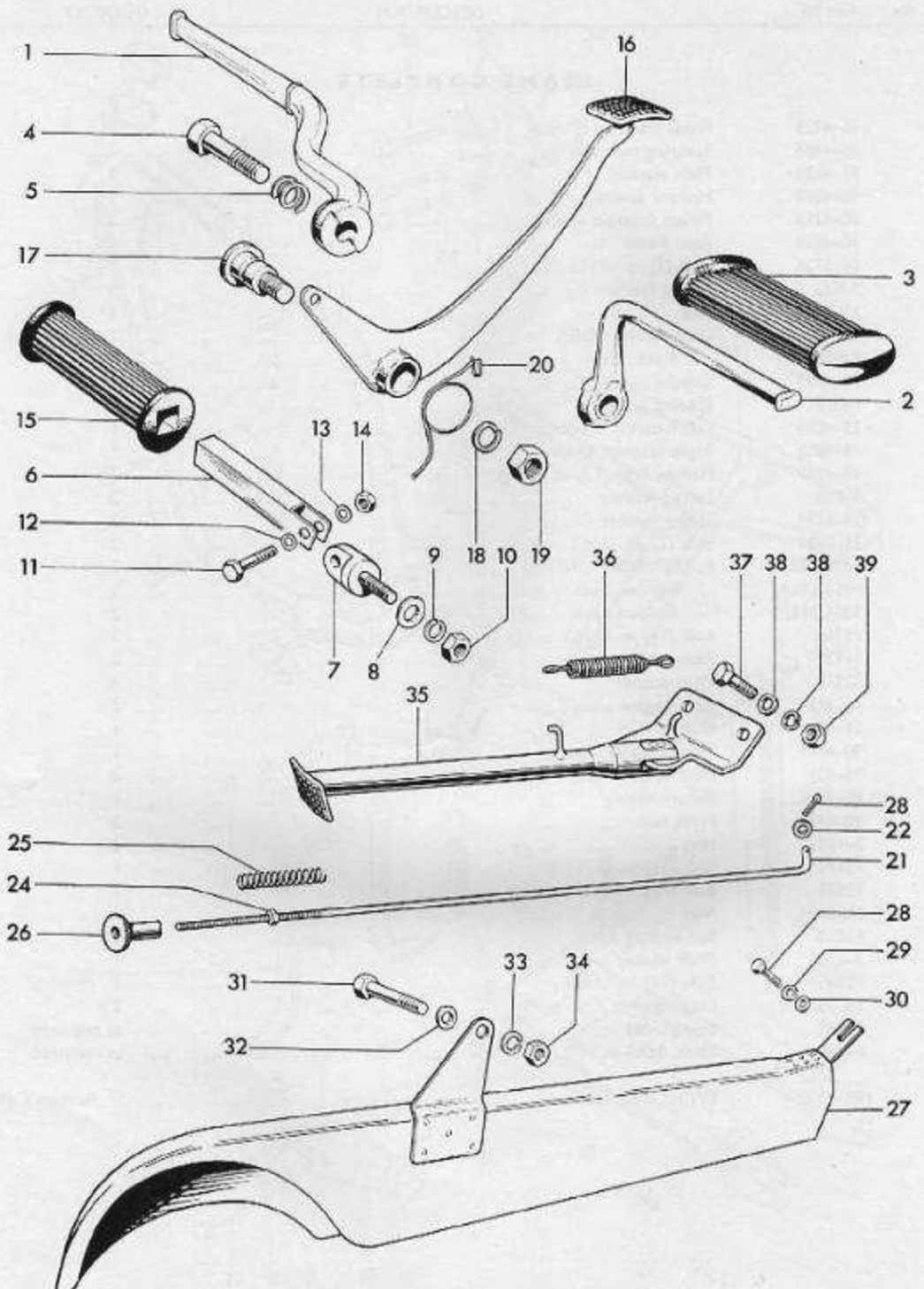

Fig. 8. FOOTRESTS, CHAINGUARD AND PROP STAND

FOOTRESTS, CHAINGUARDS AND PROP STAND

Ref. No.	Part No.	Description	Quantity
1	75-4850	Left footrest	1
2	75-4851	Right footrest	1
3	40-4850	Pedal rubber	2
4	75-4855	Bolt (1 $\frac{7}{8}$ in. U.H.)	2
5	27-6043	Spring washer	2
6	68-4835	Pillion footrest	2
7	65-4917	Footrest hanger	2
8	24-7911	Distance piece	1
9	2-522	Spring washer	2
10	2-46	Nut	2
11	29-7564	Pivot bolt ($\frac{31}{32}$ in. U.H.)	2
12	24-5914	Plain washer	2
13	36-382	Serrated washer	2
14	24-6040	Nut	2
15	29-7583	Pedal rubber	2
16	75-7025	Brake pedal	1
17	90-7024	Pedal fulcrum	1
18	3-110	Spring washer	1
19	21-5105	Nut	1
20	40-7016	Return spring	1
21	75-7030	Brake rod	1
22	2-525	Plain washer	1
23	$\frac{1}{2}$ in. x $\frac{3}{8}$ in.	Split pin	1
24	21-5102	Nut	1
25	15-1312	Spring	1
26	90-7029	Adjuster nut	1
27	75-7725	Chainguard	1
28	21-5612	Bolt ($\frac{5}{8}$ in. U.H.)	1
29	2-1462	Spring washer	1
30	27-8560	Plain washer	1
31	21-5662	Bolt ($\frac{5}{8}$ in. U.H.)	1
32	2-923	Plain washer	1
33	27-8784	Spring washer	3
34	21-5103	Nut	1
35	75-4740	Prop stand c/w bracket	1
36	65-4742	Return spring	1
37	3-1156	Bolt ($\frac{7}{8}$ in. U.H.)	2
38	2-923	Plain washer	2
39	51-51	Nut	2

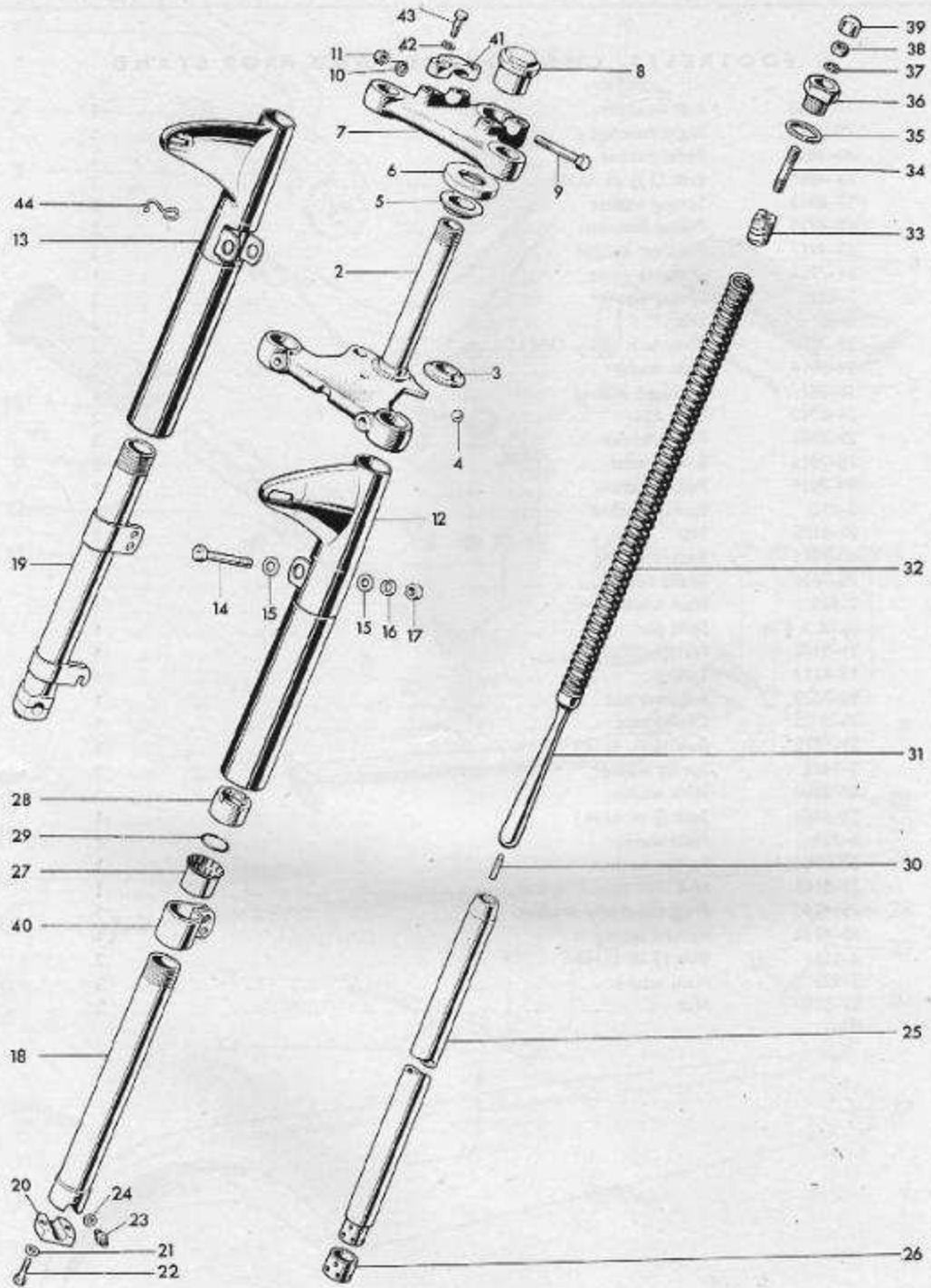

Fig. 9. TELESCOPIC FRONT FORK

Ref. No.	Part No.	DESCRIPTION	QUANTITY
TELESCOPIC FRONT FORK			
1		FORK ASSEMBLY	1
2	53-5107	Middle lug and stem	1
3	H1110	Bottom cone	1
4	S70-4	Steel ball ($\frac{3}{8}$ in. diam.)	48
5	65-5319	Top cone	1
6	65-5321	Dust cover	1
7	53-5105	Top lug	1
8	40-5018	Sleeve nut	1
9	90-5250	Bolt ($1\frac{1}{2}$ in. U.H.)	1
10	35-33	Spring washer	1
11	21-5103	Nut	1
12	†90-5306	Left top cover	1
13	†90-5307	Right top cover	1
14	21-5672	Bolt ($2\frac{1}{2}$ in. U.H.)	2
15	2-923	Plain washer	2
16	24-8784	Spring washer	2
17	21-5103	Nut	2
18	H1040	LEFT BOTTOM MEMBER C/W CAP	1
19	H1043	RIGHT BOTTOM MEMBER C/W CAP	1
20	H856	Cap	2
21	E1612	Serrated washer	4
22	W932	Bolt (1 in. U.H.)	4
23	90-5318	Drain stud	2
24	WE170	Fibre washer	2
25	90-5258	STANCHION C/W BEARING	2
26	H845	Lower bearing	2
27	H1046	Top bearing	2
28	90-5262	Dust excluder sleeve nut	2
29	H1995	Oil seal	2
30	H1048	Stud	2
31	90-5249	Restrictor	2
32	H848	Spring	2
33	H849	Scroll	2
34	90-5253	Stud	2
35	90-5256	Plain washer	2
36	90-5251	Sleeve nut	2
37	E2287	Serrated washer	2
38	42-101	Nut	2
39	90-5255	Cap	2
40	H2006	Mudguard clip	2
41	65-5333	Handlebar clamp	2
42	15-5155	Plain washer	2
43	68-5056	Bolt ($1\frac{1}{2}$ in. U.H.)	2
44	90-5268	Cable clip	1

† When top covers are required separately for Bantam Cub use
75-5183 Left top cover
75-5184 Right top cover

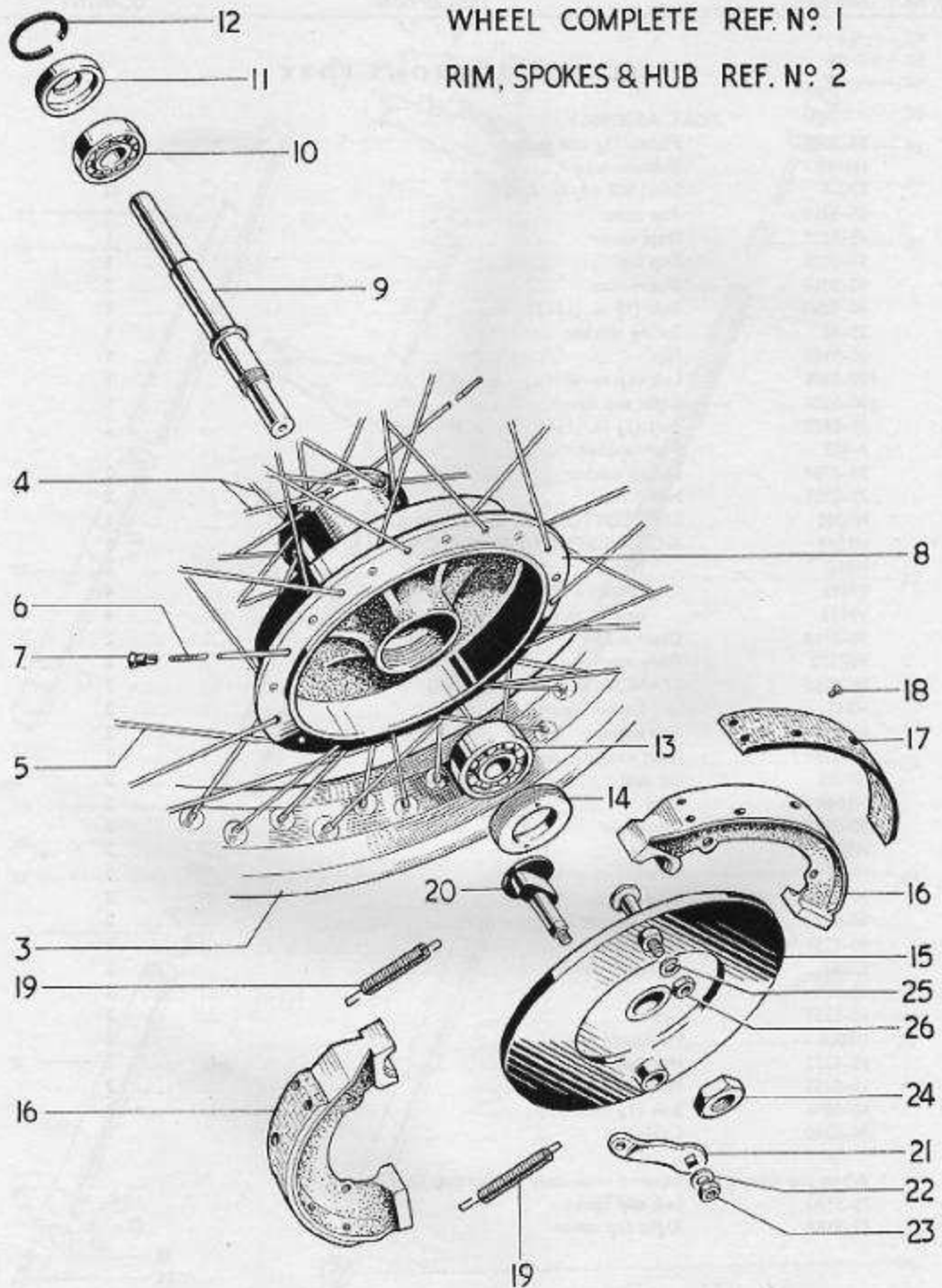

Fig. 10. FRONT WHEEL, BANTAM CUB

FRONT WHEEL, BANTAM CUB

Ref. No.	Part No.	DESCRIPTION	QUANTITY
1		FRONT WHEEL COMPLETE	1
2		RIM, SPOKES AND HUB ASSEMBLY	1
3	9C-6203	Front wheel rim, WM1-18	1
4	9C-5693	Spoke (12G x 8½ in.) c/w nipple	20
5	9C-5695	Spoke (12G x 6½ in.) c/w nipple	10
6	9C-5696	Spoke (12G x 6 in.) c/w nipple	10
7	W965	Nipple	40
8	W961	Hub and brake drum	1
9	W967	Wheel spindle	1
10	T530	Left bearing	1
11	W966	Dust cover	1
12	T532	Circlip	1
13	H826	Right bearing	1
14	W968	Retaining ring	1
15	W969	Brake anchor plate	1
16	W977	BRAKE SHOE C/W LINING	2
17	W978	Brake lining	2
18	W979	Brass rivet	12
19	W200	Shoe return spring	1
20	W1128	Brake cam	1
21	W1133	Brake cam lever	1
22	S25-71	Plain washer	1
23	T224	Nut	1
24	W1093	Anchor plate nut	1
25	S26-1	Spring washer	1
26	S1-52	Nut	1

WHEEL COMPLETE Ref. No.1
RIM, SPOKES & HUB Ref. No.2

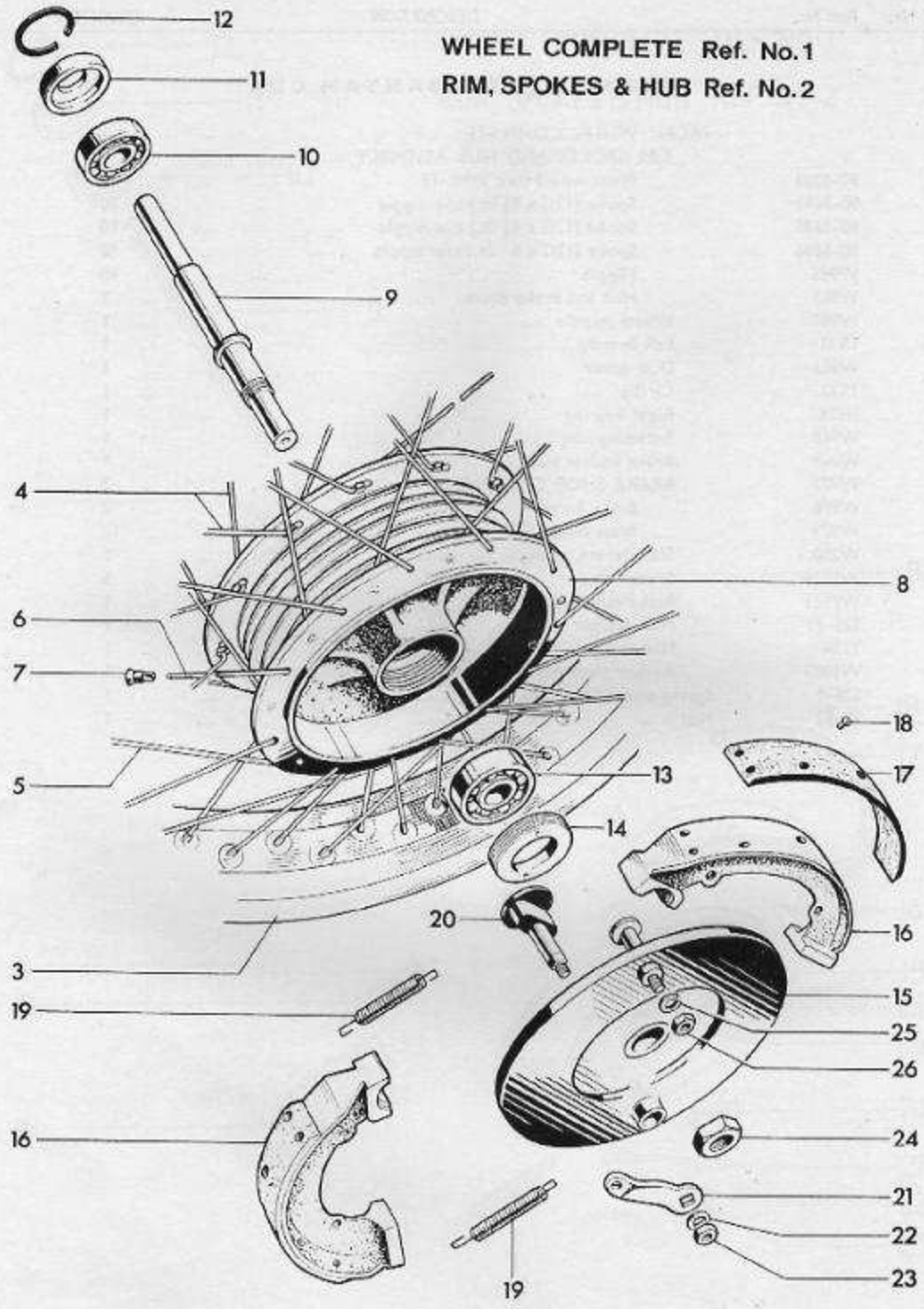

Fig. 11. FRONT WHEEL, SUPER CUB

FRONT WHEEL, SUPER CUB

Ref. No.	Part No.	DESCRIPTION	QUANTITY
1		FRONT WHEEL COMPLETE	1
2		RIM, SPOKES AND HUB ASSEMBLY	1
3	90-6203	Front wheel rim, WM1-18	1
4	90-5727	Spoke (12G x 6 $\frac{1}{32}$ in.)	20
5	90-5695	Spoke (12G x 6 $\frac{1}{2}$ in.)	10
6	90-5696	Spoke (12G x 6 $\frac{1}{8}$ in.)	10
7	W965	Nipple	40
8	90-5729	Hub and brake drum	1
9	W967	Wheel spindle	1
10	T530	Left bearing	1
11	W966	Dust cover	1
12	T532	Circlip	1
13	H826	Right bearing	1
14	W968	Retaining ring	1
15	W969	Brake anchor plate	1
16	W977	BRAKE SHOE C/W LINING	2
17	W978	Brake lining	2
18	W979	Brass rivet	12
19	W200	Shoe return spring	2
20	W1128	Brake cam	1
21	W1133	Brake cam lever	1
22	S25-71	Plain washer	1
23	T224	Nut	1
24	W1093	Anchor plate nut	1
25	S26-1	Spring washer	1
26	S1-S2	Nut	1

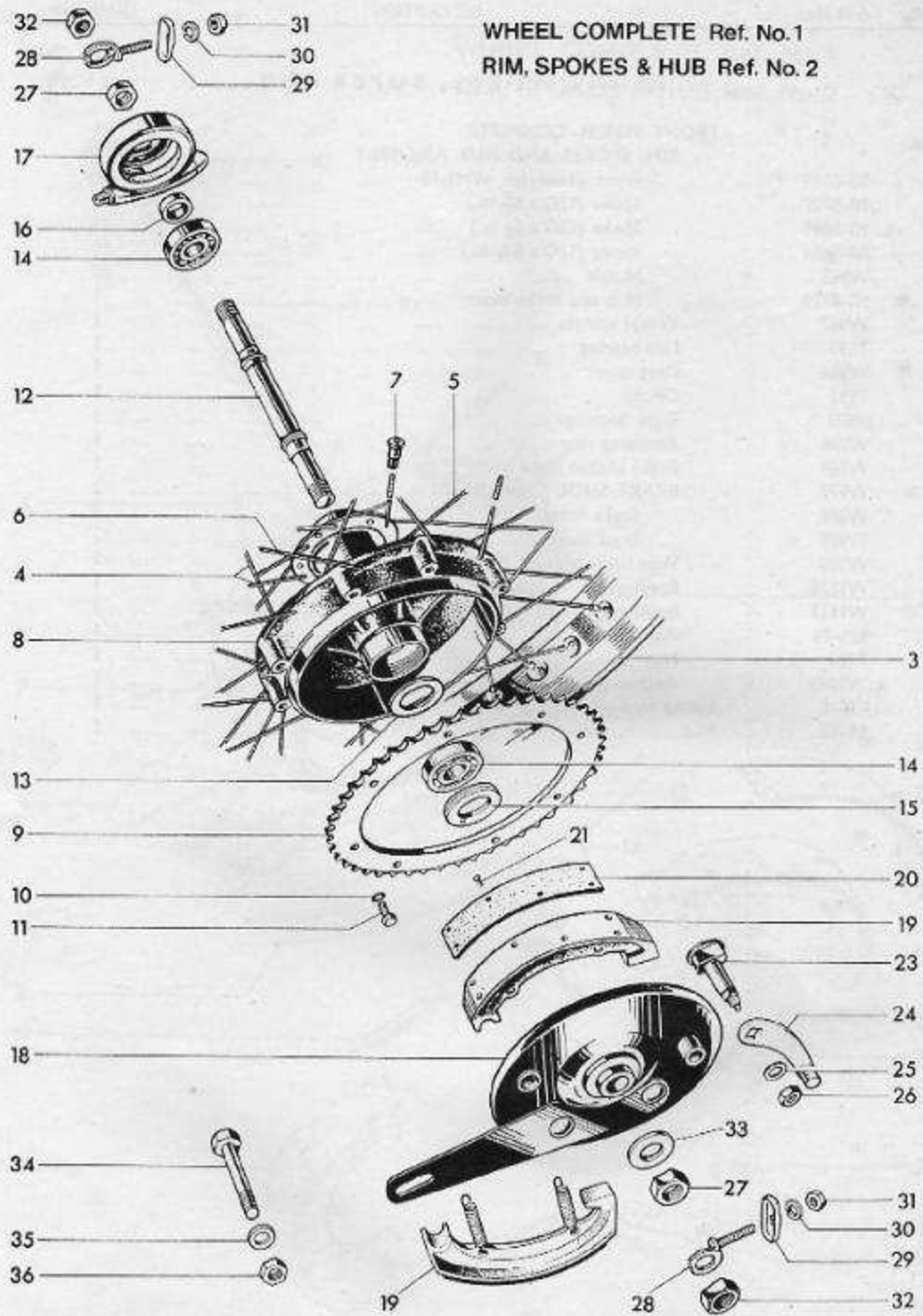

Fig. 12. REAR WHEEL, BANTAM CUB

REAR WHEEL, BANTAM CUB

Ref. No.	Part No.	DESCRIPTION	QUANTITY
1		REAR WHEEL COMPLETE	1
2		RIM, SPOKES AND HUB ASSEMBLY	1
3	90-6271	Rear wheel rim WM1-18	1
4	90-6272	Spoke	20
5	90-6274	Spoke	10
6	90-6273	Spoke	10
7	27-6810	Nipple	40
8	90-6205	Hub and brake drum	1
9	90-6240	Sprocket (47T)	1
10	W1122	Spring washer	8
11	W1322	Bolt ($\frac{5}{8}$ in. U.H.)	8
12	90-6231	Spindle	1
13	W987	Backing ring	1
14	H826	Bearing	2
15	W988	Retaining ring	1
16	90-6230	Distance piece	1
17	D489	Speedometer gearbox	1
18	90-6223	Brake anchor plate	1
19	W977	BRAKE SHOE C/W LINING	2
20	W978	Brake lining	2
21	W979	Brass rivet	12
22	W200	Shoe return spring	2
23	W1128	Brake cam	1
24	90-6228	Brake cam lever	1
25	S25-71	Plain washer	1
26	T224	Nut	1
27	29-6238	Nut	2
28	W1224	Chain adjuster	2
29	W1227	End plate	2
30	S26-2	Spring washer	2
31	F879	Nut	2
32	W1000	Nut	2
33	25-6014	Washer	1
34	21-5713	Bolt ($\frac{3}{8}$ in. U.H.)	1
35	2-2903	Spring washer	1
36	21-5104	Nut	1

WHEEL COMPLETE Ref. No.1
RIM, SPOKES & HUB Ref. No.2

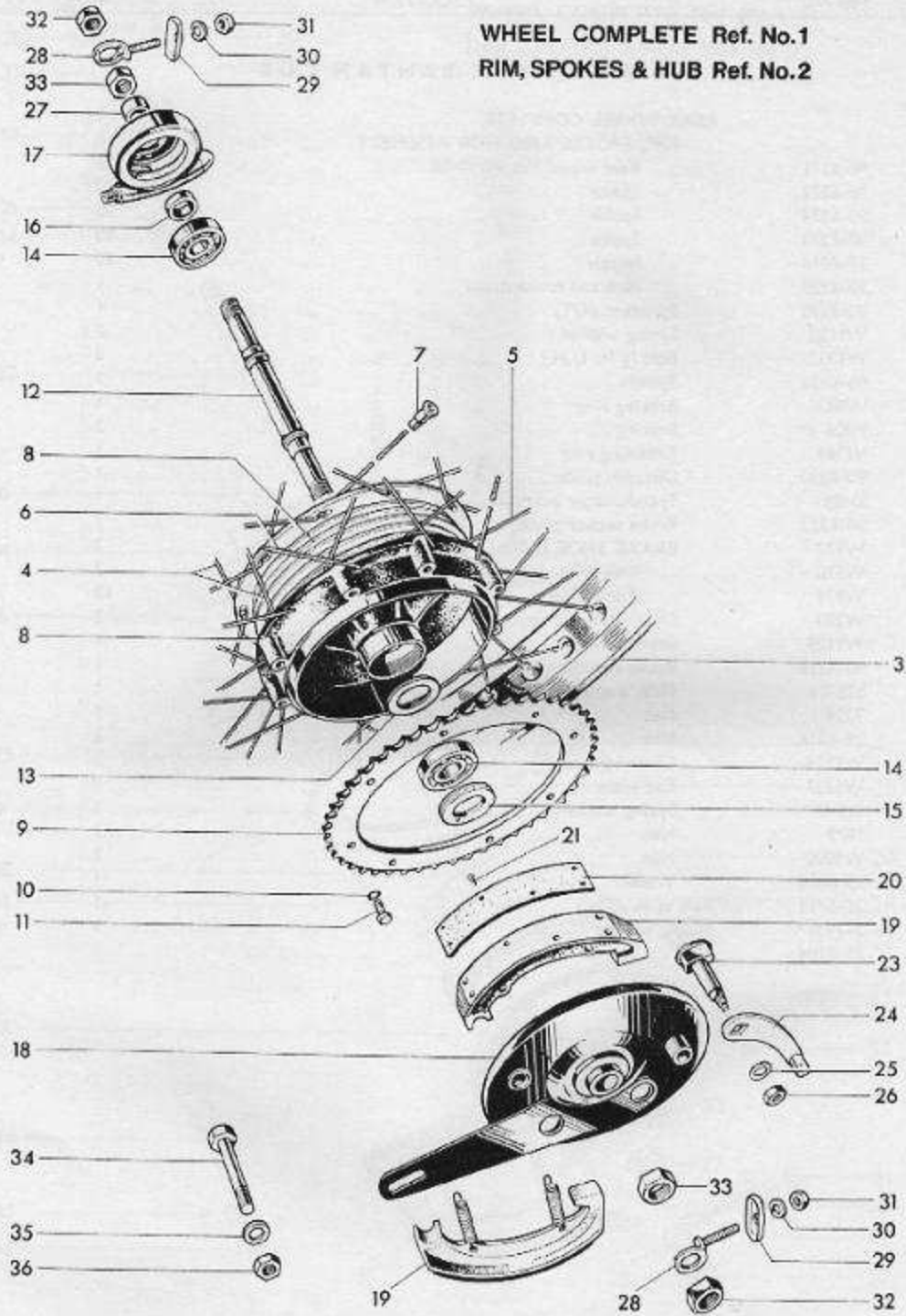

Fig. 13. REAR WHEEL, SUPER CUB

REAR WHEEL, SUPERCUB

Ref. No.	Part No.	DESCRIPTION	QUANTITY
1		REAR WHEEL COMPLETE	1
2		RIM, SPOKES AND HUB ASSEMBLY	1
3	90-6271	Rear wheel rim WM1-18	1
4	90-6275	Spoke	20
5	90-6274	Spoke	10
6	90-6273	Spoke	10
7	27-6810	Nipple	40
8	90-6260	Hub and brake drum	1
9	90-6240	Sprocket (47T)	1
10	W1122	Spring washer	8
11	W1322	Bolt ($\frac{5}{8}$ in. U.H.)	8
12	90-6265	Spindle	1
13	W987	Backing ring	1
14	H826	Bearing	2
15	W988	Retaining ring	1
16	90-6267	Distance piece	1
17	D489	Speedometer gearbox	1
18	90-6223	Brake anchor plate	1
19	W977	BRAKE SHOE C/W LINING	2
20	W978	Brake lining	2
21	W979	Brass rivet	12
22	W200	Shoe return spring	2
23	W1128	Brake cam	1
24	90-6228	Brake cam lever	1
25	S25-71	Plain washer	1
26	T224	Nut	1
27	90-6266	Distance piece	2
28	W1224	Chain adjuster	2
29	W1227	End plate	2
30	S26-2	Spring washer	2
31	F879	Nut	2
32	W1000	Nut	2
33	29-6238	Nut	1
34	21-5713	Bolt ($\frac{5}{8}$ in. U.H.)	1
35	2-2903	Spring washer	1
36	21-5104	Nut	1

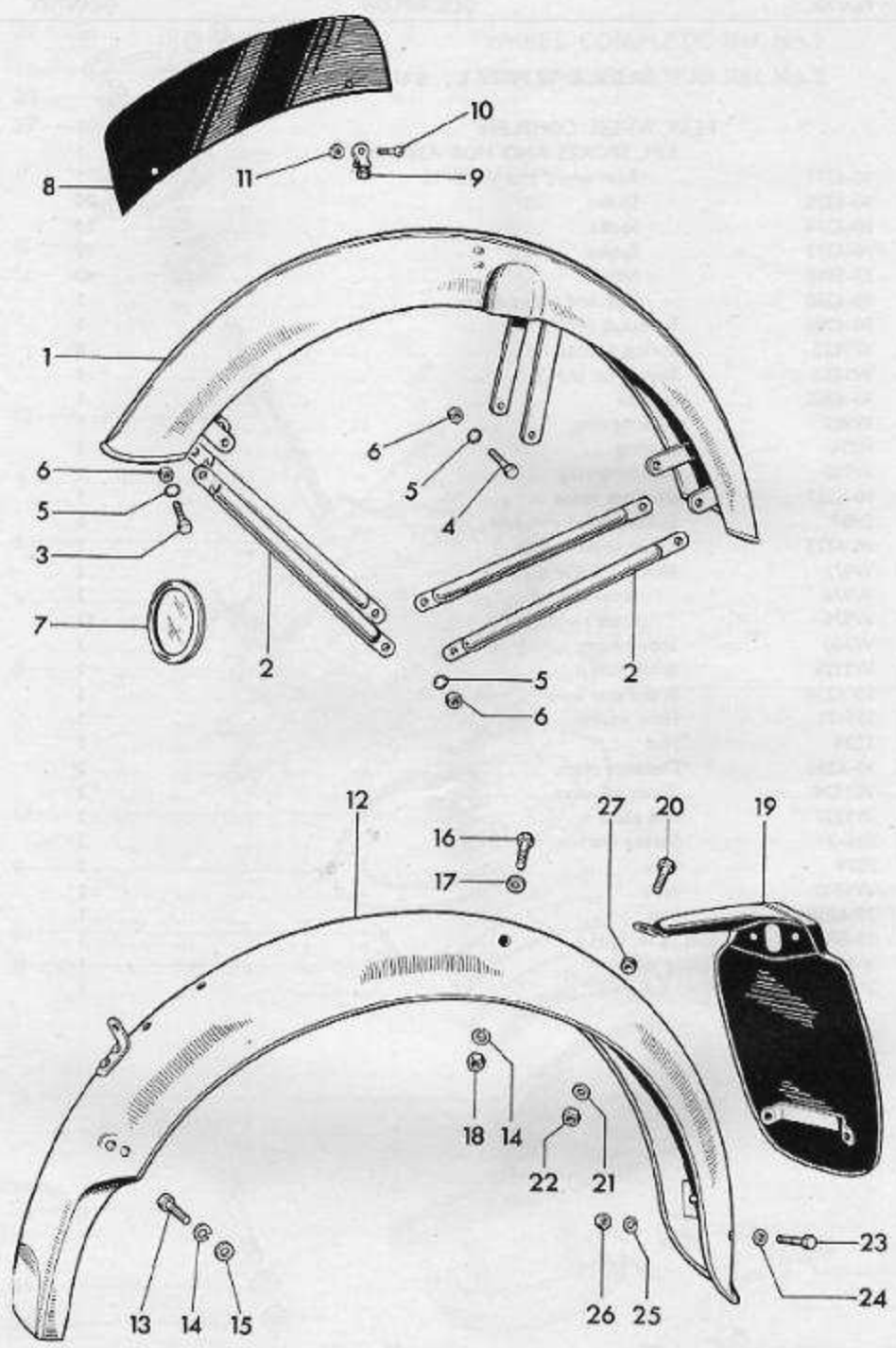

FIG. 14. MUDGUARDS, BANTAM CUB

MUDGUARDS, BANTAM CUB

1	H929	Front mudguard	1
2	75-6593	Stay	4
3	DS57	Bolt ($\frac{7}{16}$ in. U.H.)	4
4	GS218	Bolt ($\frac{7}{16}$ in. U.H.)	4
5	E1612	Serrated washer	10
6	F879	Nut	10
7	D261	Licence holder	1
8	F6469	Number plate	1
9	H741	Clip assembly	2
10	F4715	Screw ($\frac{1}{2}$ in. U.H.)	2
11	H745	Nut	2
12	75-6798	Rear mudguard	1
13	21-5663	Bolt ($\frac{3}{4}$ in. U.H.)	2
14	24-8784	Spring washer	4
15	15-5155	Plain washer	2
16	21-5662	Bolt ($\frac{3}{8}$ in. U.H.)	2
17	2-923	Plain washer	2
18	21-5103	Nut	2
19	75-6795	Number plate	1
20	F929	Bolt ($1\frac{1}{2}$ in. U.H.)	1
21	S26-3	Spring washer	1
22	S1-51	Nut	1
23	F1149	Bolt ($\frac{3}{8}$ in. U.H.)	2
24	F5410	Plain washer	2
25	S26-2	Spring washer	2
26	F879	Nut	2
27	90-6985	Grommet	2

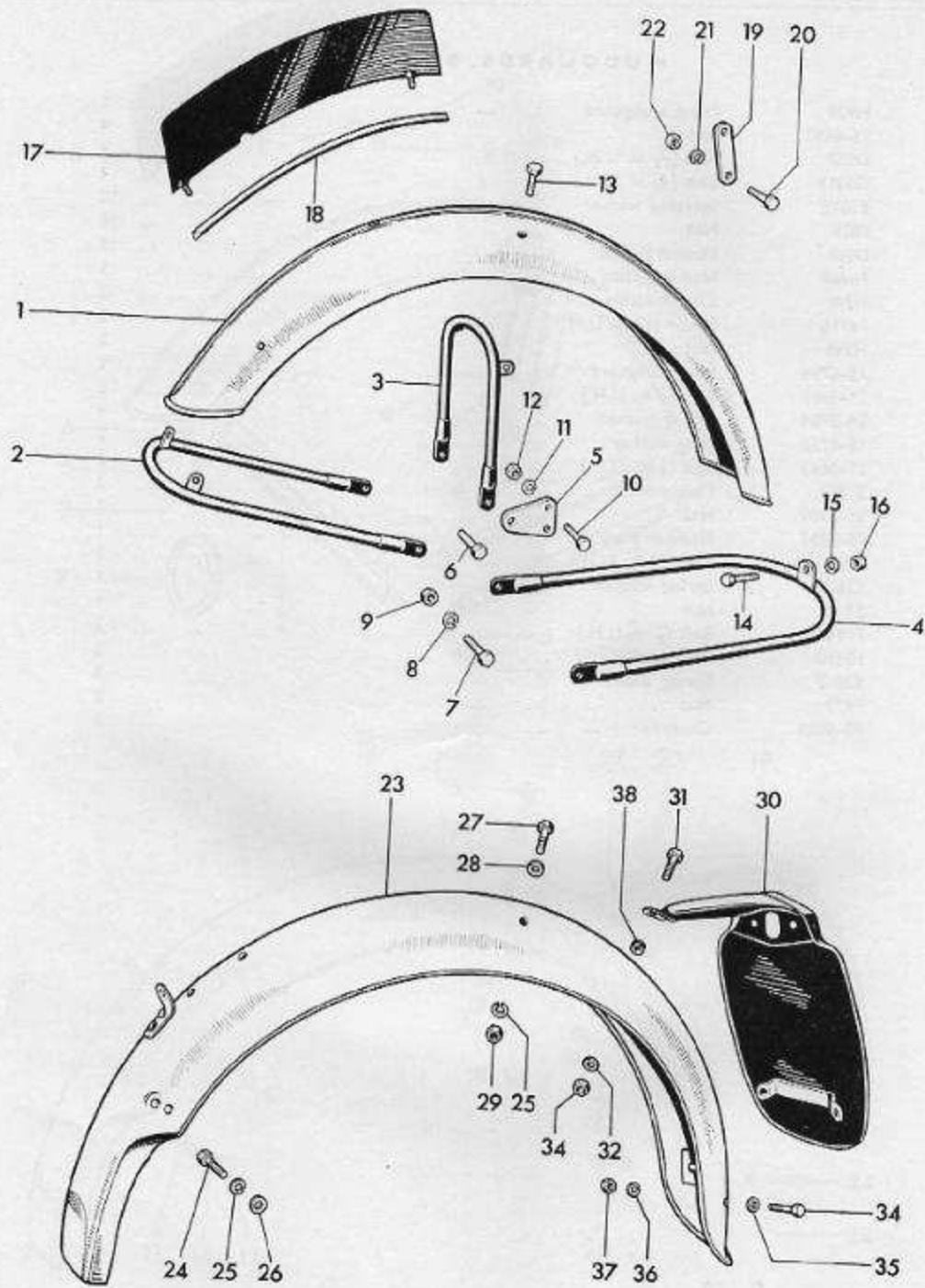

Fig. 15. MUDGUARDS, SUPER CUB

MUDGUARDS, SUPER CUB

Ref. No.	Part No.	DESCRIPTION	QUANTITY
1	90-6579	Front mudguard	1
2	40-6599	Front stay	1
3	40-6601	Bridge	1
4	40-6592	Bottom stay	1
5	90-6593	Bracket	2
6	24-6770	Bolt ($\frac{3}{8}$ in. U.H.)	2
7	27-6037	Bolt ($\frac{7}{8}$ in. U.H.)	2
8	24-8784	Spring washer	4
9	S1-51	Nut	4
10	GS218	Bolt ($\frac{3}{8}$ in. U.H.)	4
11	S26-2	Spring washer	12
12	F.879	Nut	12
13	D557	Bolt ($\frac{7}{8}$ in. U.H.)	4
14	28-2338	Bolt ($\frac{3}{4}$ in. U.H.)	1
15	S26-3	Spring washer	1
16	24-5160	Nut	1
17	90-6576	Number plate	1
18	42-6558	Beading	1
19	40-6517	Licence holder bracket	1
20	21-5611	Bolt ($\frac{1}{2}$ in. U.H.)	1
21	E.1612	Serrated washer	1
22	21-5102	Nut	1
23	75-6798	Rear mudguard	1
24	21-5663	Bolt ($\frac{3}{8}$ in. U.H.)	2
25	24-8784	Spring washer	4
26	15-5155	Plain washer	2
27	21-5662	Bolt ($\frac{3}{8}$ in. U.H.)	2
28	2-923	Plain washer	2
29	21-5103	Nut	2
30	75-6795	Number plate	1
31	F.929	Bolt ($\frac{1}{2}$ in. U.H.)	1
32	S26-3	Spring washer	1
33	S1-51	Nut	1
34	F.1149	Bolt ($\frac{7}{8}$ in. U.H.)	2
35	F.5410	Plain washer	2
36	S26-2	Spring washer	2
37	F.879	Nut	2
38	90-6985	Grommet	2

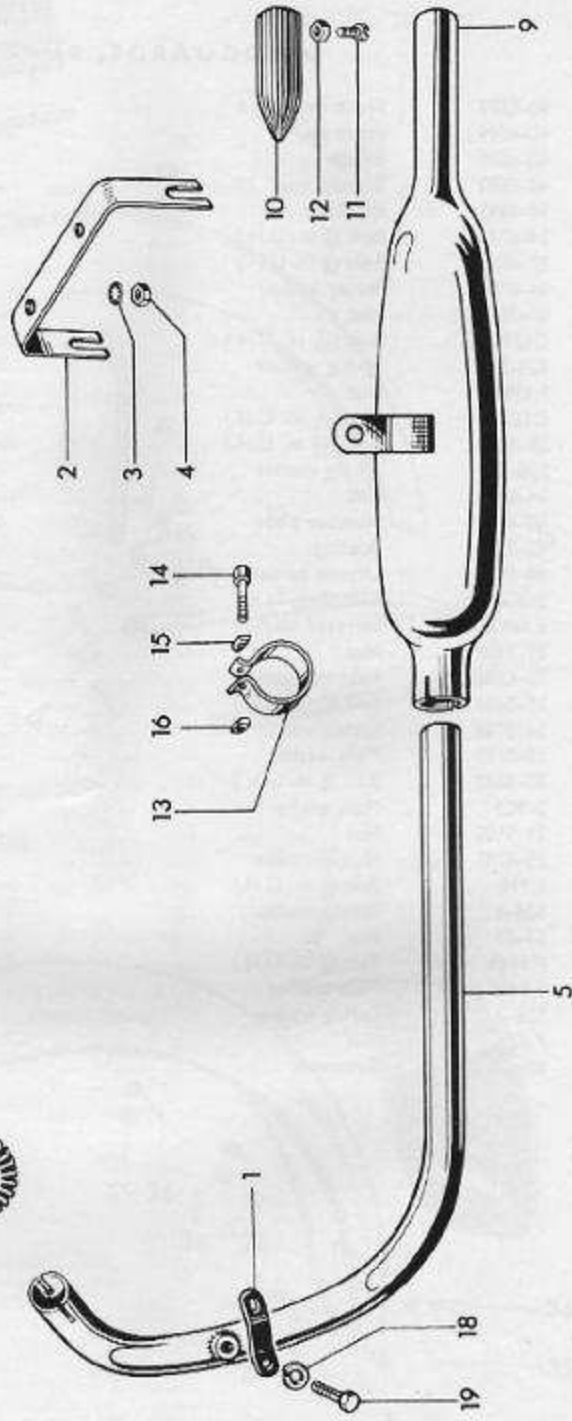
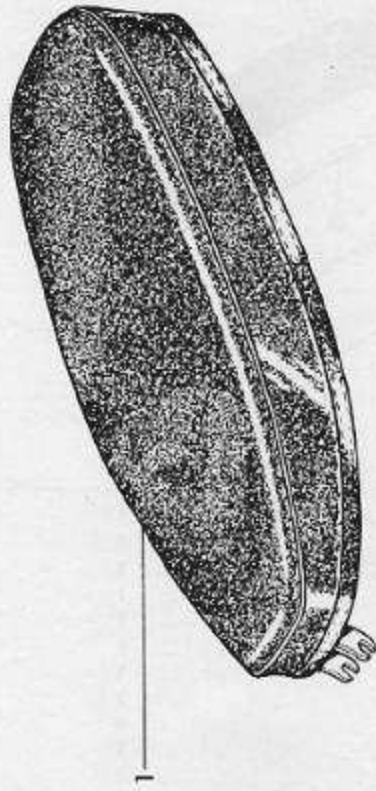

FIG. 16. TWINSEAT AND EXHAUST SYSTEM

Ref. No. Part No.

DESCRIPTION

QUANTITY

TWINSEAT AND EXHAUST SYSTEM

Ref. No.	Part No.	DESCRIPTION	QUANTITY
1	75-9164	Twinseat	1 Bantam Cub
1	75-9171	Twinseat	1 Super Cub
2	90-9277	Rear bracket	1
3	S26-2	Spring washer	2
4	2-51	Nut	2
5	75-2748	Exhaust pipe	1
6	E.4932	Clip	1
7	S25-13	Plain washer	1
8	E.3260	Bolt ($\frac{3}{8}$ in. U.H.)	1
9	75-2744	Silencer	1
10	E.4076	Silencer mute	1
11	H.689	Screw ($\frac{1}{4}$ in. U.H.)	as required
12	H.691	Nut	as required
13	E.3269	Clip	1
14	TE.164E	Bolt	1
15	TE.164D	"D" washer	1
16	RE.164C	"D" nut	1
17	75-2750	Bracket	1
18	S26-3	Spring washer	1
19	F.929	Bolt ($\frac{1}{2}$ in. U.H.)	1

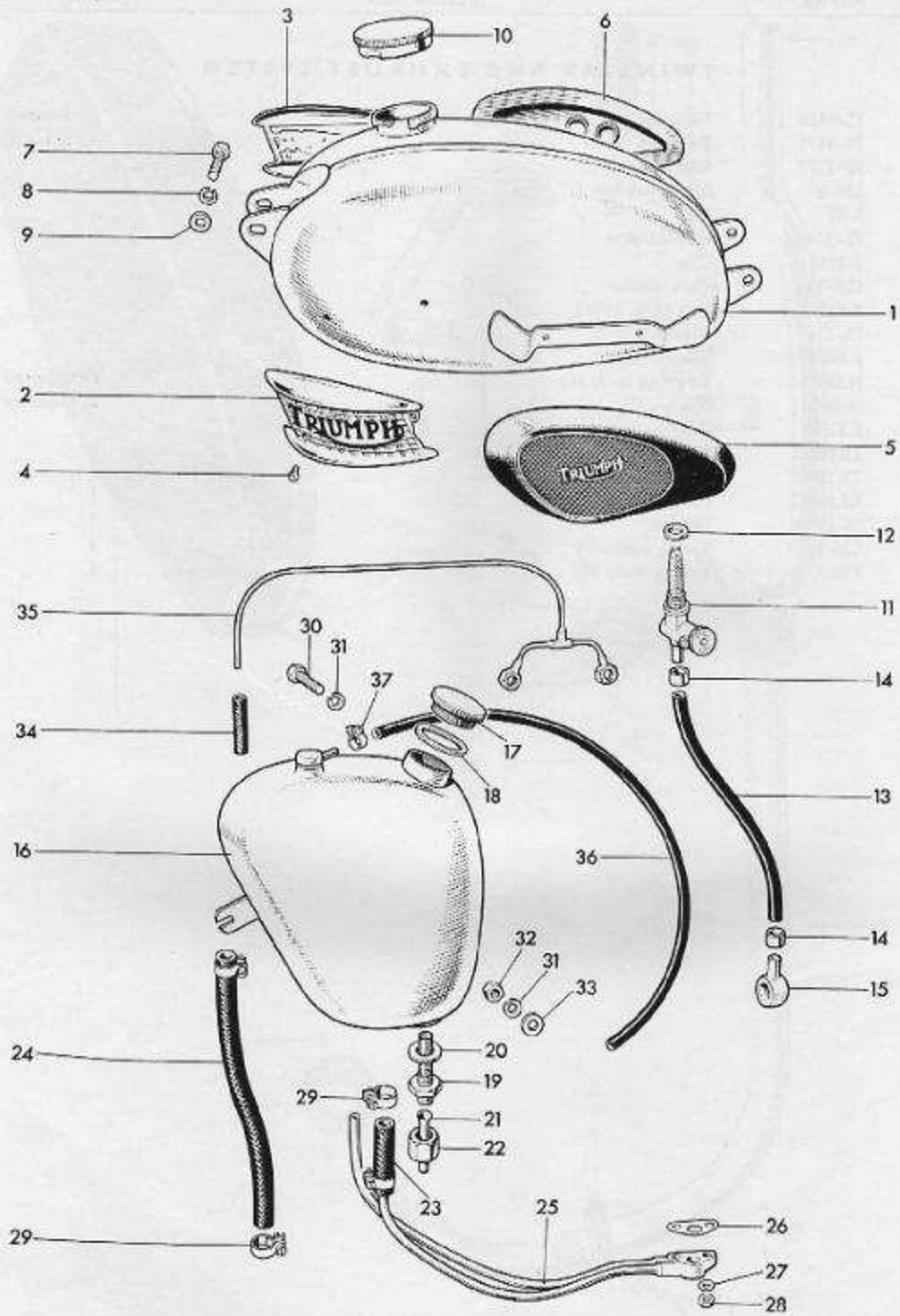

Fig. 17. PETROL AND OIL TANKS, BANTAM CUB

PETROL AND OIL TANKS, BANTAM CUB

Ref. No.	Part No.	DESCRIPTION	QUANTITY
1	90-8095	Petrol tank	1
2	F4570	Left styling unit	1
3	F4571	Right styling unit	1
4	F4468	Screw ($\frac{1}{16}$ in. U.H.)	4
5	F1606	Left knee grip	1
6	F1605	Right knee grip	1
7	21-5662	Bolt ($\frac{3}{8}$ in. U.H.)	2
8	24-8784	Spring washer	2
9	2-923	Plain washer	2
10	29-7898	Filler cap	1
11	53-8031	Petrol tap	1
12	PT104B	Fibre washer	1
13	75-8091	Petrol pipe	1
14	90-8032	Ferrule	2
15	42-8078	Banjo	1
16	75-8345	Oil tank	1
17	65-8500	Filler cap	1
18	67-42	Fibre washer	1
19	F3179	Filter	1
20	F1713	Fibre washer	1
21	F3655	Feed pipe	1
22	F3182	Union nut	1
23	75-8347	Feed connection	1
24	75-8348	Return connection	1
25	75-391	Oil pipes and junction block	1
26	E3274	Joint washer	1
27	S25-13	Plain washer	1
28	F879	Nut	1
29	68-8343	Clip	4
30	1-5609	Bolt ($\frac{3}{8}$ in. U.H.)	1
31	24-8784	Spring washer	2
32	S1-51	Nut	1
33	2-923	Plain washer	1
34	E3383	Rocker feed connection	1
35	75-388	Rocker oil pipe	1
36	75-8349	Chain oiler pipe	1
37	77-8340	Clip	1

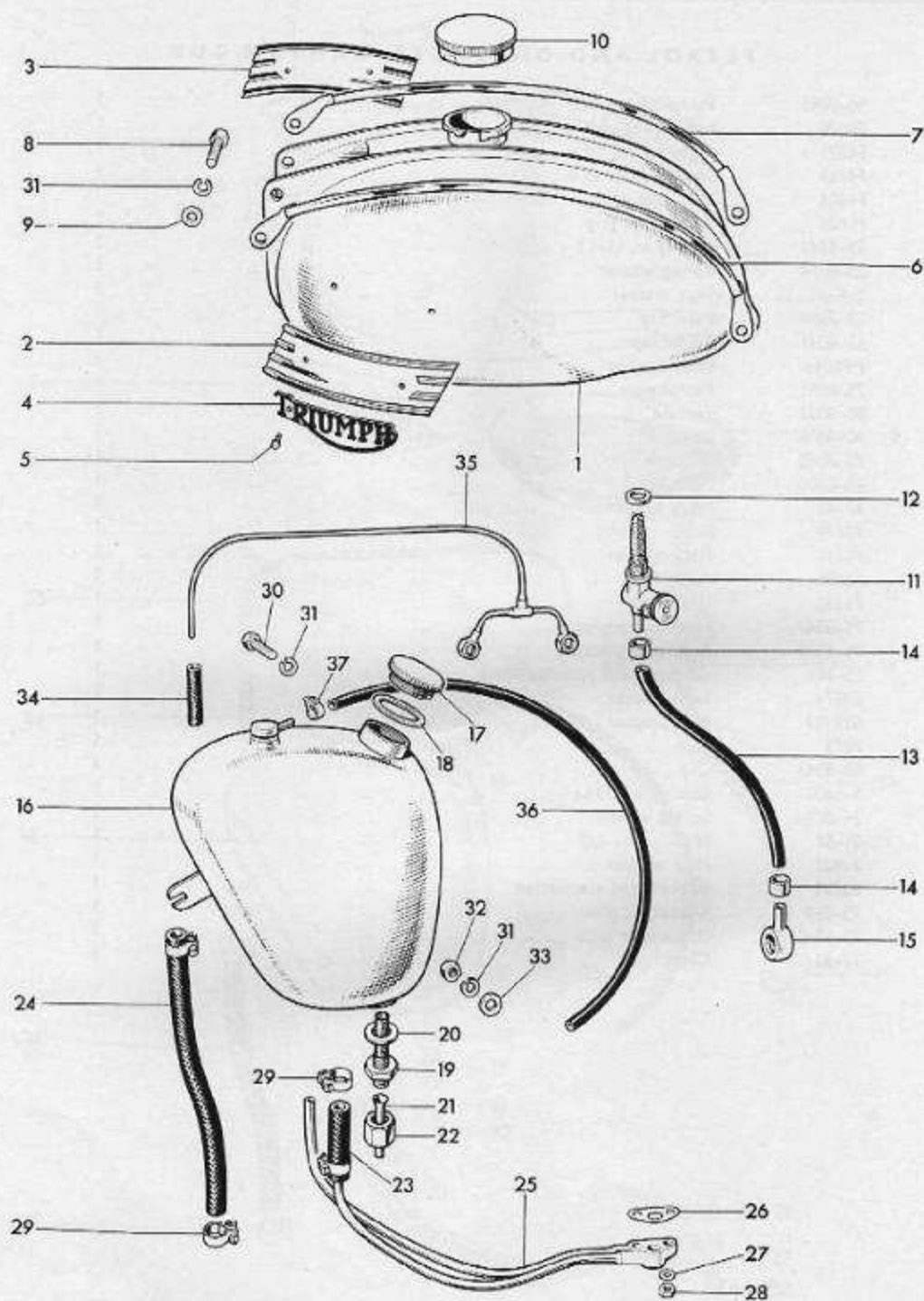

Fig. 10. PETROL AND OIL TANKS, SUPER CUB

PETROL AND OIL TANKS, SUPER CUB

Ref. No.	Part No.	Description	Quantity
1	75-8095	Petrol tank	1
2	75-8031	Left styling unit	1
3	75-8030	Right styling unit	1
4	F3496	Name plate	2
5	F4468	Screw ($\frac{5}{16}$ in. U.H.)	4
6	75-8096	Left beading	1
7	75-8100	Right beading	1
8	21-5662	Bolt ($\frac{5}{8}$ in. U.H.)	2
9	2-923	Plain washer	2
10	29-7898	Filler cap	1
11	53-8031	Petrol tap	1
12	PT104B	Fibre washer	1
13	75-8091	Petrol pipe	1
14	90-8032	Ferrule	2
15	42-8078	Banjo	1
16	75-8345	Oil tank	1
17	65-8500	Filler cap	1
18	67-42	Fibre washer	1
19	F3179	Filter	1
20	F1713	Fibre washer	1
21	F3655	Feed pipe	1
22	F3182	Union nut	1
23	75-8347	Feed connection	1
24	75-8348	Return connection	1
25	75-391	Oil pipes and junction block	1
26	E3274	Joint washer	1
27	S25-13	Plain washer	1
28	F879	Nut	1
29	68-8343	Clip	4
30	1-5609	Bolt ($\frac{5}{8}$ in. U.H.)	1
31	24-8784	Spring washer	4
32	S1-51	Nut	1
33	2-923	Plain washer	1
34	E3383	Rocker feed connection	1
35	75-388	Rocker oil pipe	1
36	75-8349	Chain oiler pipe	1
37	66-8340	Clip	1

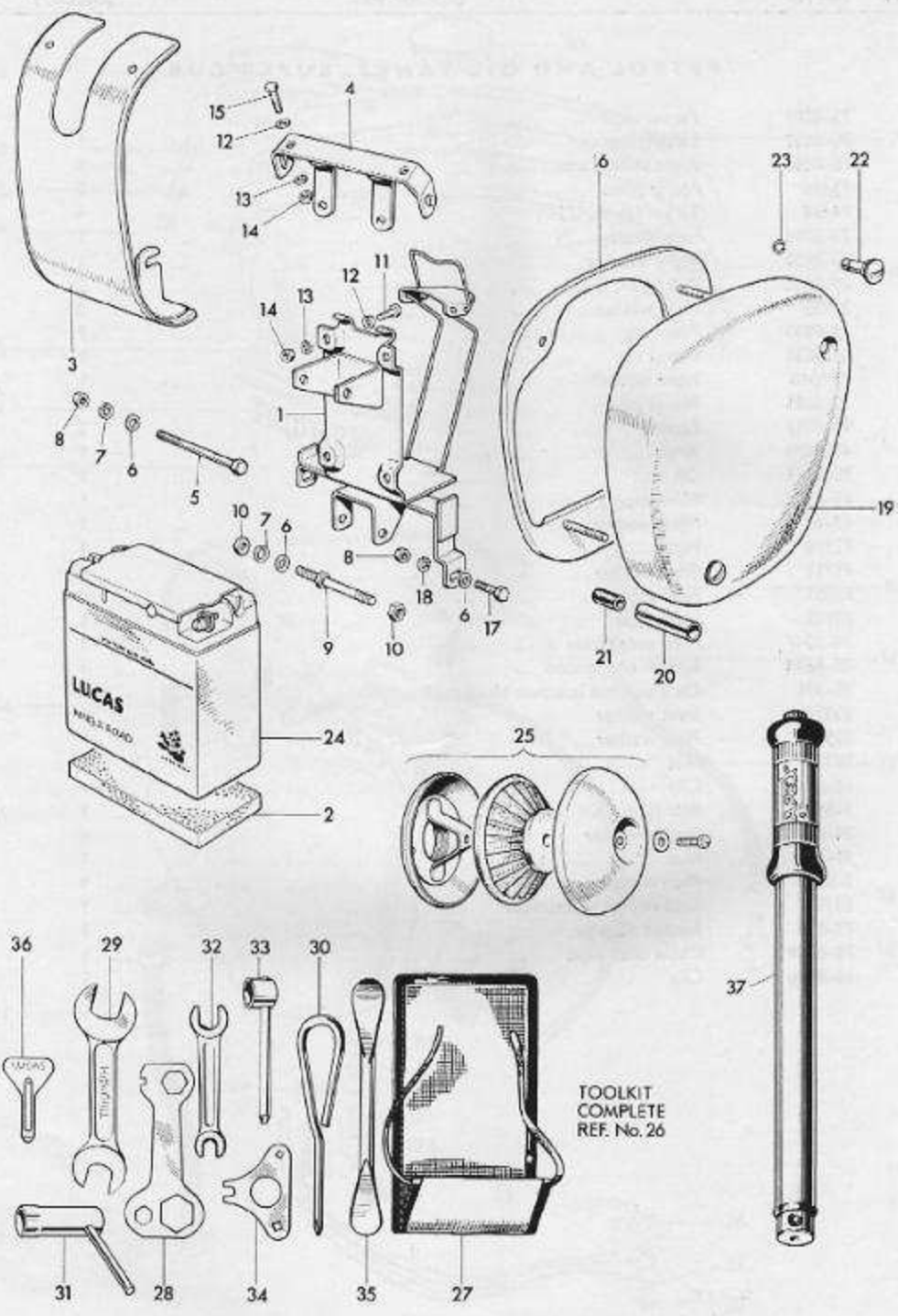
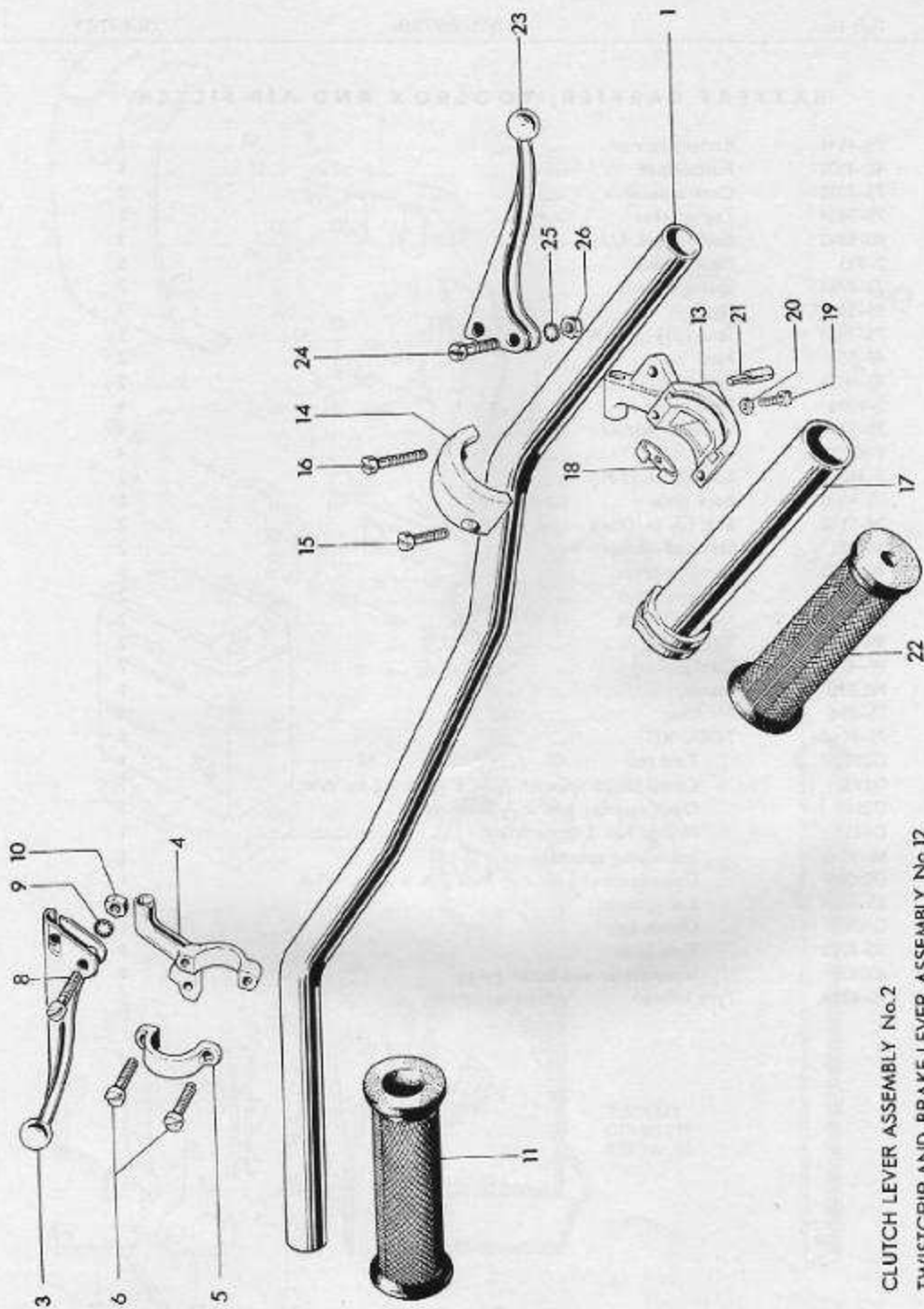

Fig. 19. BATTERY CARRIER, TOOLBOX AND AIR FILTER

BATTERY CARRIER, TOOLBOX AND AIR FILTER

1	75-4541	Battery carrier	1
2	40-4508	Rubber pad	1
3	75-7820	Centre panel	1
4	75-7824	Top bracket	1
5	40-5043	Bolt (2-1/2 in. U.H.)	1
6	2-923	Plain washer	5
7	24-8784	Spring washer	3
8	51-51	Nut	3
9	75-7828	Stud (2-1/8 in. O.A.)	1
10	46-55	Nut	3
11	42-4574	Bolt (1/2 in. U.H.)	2
12	2-1096	Plain washer	4
13	29-3319	Serrated washer	4
14	1-4616	Nut	4
15	2-360	Bolt (1/2 in. U.H.)	2
16	75-4540	Back plate	1
17	24-7148	Bolt (7/8 in. U.H.)	2
18	36-382	Serrated washer	2
19	40-9003	Toolbox cover	1
20	40-9009	Distance piece	2
21	40-9020	Rubber sleeve	2
22	89-4310	Thumb nut	2
23	89-4311	Circlip	2
24	MLZ9E	Battery	1
25	75-394	Air filter	1
26	75-9160	TOOL KIT	1
27	D291	Tool roll	1
28	D293	Combination spanner 3/8 in. x 1/2 in. x 1/2 in. Whit.	1
29	D299	Open spanner 3/8 in. x 1/2 in. Whit.	1
30	D335	Phillips No. 2 screwdriver	1
31	66-9132	Spark plug spanner	1
32	D292	Open spanner 1/2 in. x 3/4 in. x 1/2 in. x 1/2 in. Whit.	1
33	65-9115	Box spanner	1
34	DA70	Clutch key	1
35	90-9018	Tyre lever	1
36	400935	Screwdriver and feeler gauge	1
37	90-9237	Tyre inflator	1



CLUTCH LEVER ASSEMBLY No.2
 TWISTGRIP AND BRAKE LEVER ASSEMBLY No.12

Fig. 20. HANDLEBAR AND CONTROL LEVERS

HANDLEBAR AND CONTROL LEVERS

Ref. No.	Part No.	Description	Quantity
1	68-4968	Handlebar	1
2	18-1091	CLUTCH LEVER ASSEMBLY	1
3	18-1092	Clutch lever	1
4	18-1035	Clutch lever bracket	1
5	12-595	Clamp	1
6	11-013	Clamp screw	1
7	11-014	Clamp screw	1
8	18-087	Fulcrum screw	1
9	70-016	Spring washer	1
10	18-717	Nut	1
11	16-069	Handlebar grip	1
12	368-23	TWISTGRIP AND BRAKE LEVER ASSEMBLY	1
13	368-018	Body, bottom half	1
14	368-002	Body, top half	1
15	11-013	Clamp screw	1
16	11-014	Clamp screw	1
17	366-004	Rotor	1
18	366-007	Friction spring	1
19	16-009	Friction spring screw	1
20	16-010	Lock nut	1
21	366-006	Cable stop	1
22	16-070	Handlebar grip	1
23	368-019	Front brake lever	1
24	18-087	Fulcrum screw	1
25	70-016	Spring washer	1
26	18-717	Nut	1

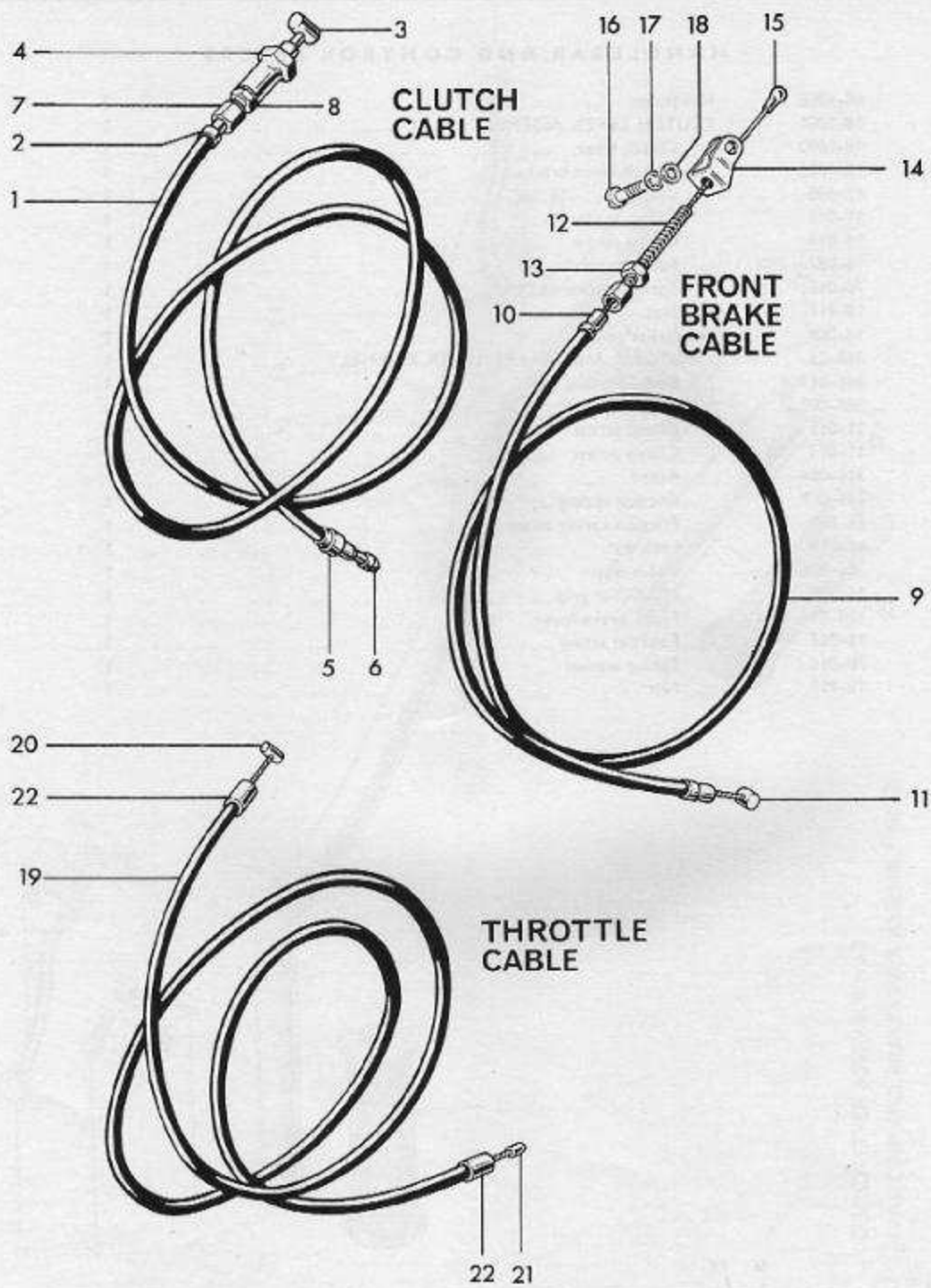

Fig. 21. CONTROL CABLES

Ref. No. Part No.

DESCRIPTION

QUANTITY

CONTROL CABLES

1	D504	CLUTCH CABLE	1
2	D103	Ferrule	2
3	D506	Nipple (handlebar end)	2
4	D281	Abutment	1
5	D333	Abutment	1
6	D334	Nipple	1
7	D319	Cable adjuster	1
8	D268	Nut	1
9	90-8599	FRONT BRAKE CABLE	1
10	27-9353	Ferrule	2
11	66-8747	Nipple (handlebar end)	1
12	90-8580	Cable adjuster	2
13	90-8582	Nut	1
14	90-8531	Clevis	1
15	27-9330	Nipple	1
16	2-510	Screw ($\frac{3}{16}$ in. U.H.)	1
17	E1612	Serrated washer	1
18	2-443	Plain washer	1
19	90-8595	THROTTLE CABLE	1
20	D411	Nipple (handlebar end)	1
21	NS191	Nipple	1
22	18/145	Ferrule	2

**CARBURETTER COMPLETE
REF. No. 1**

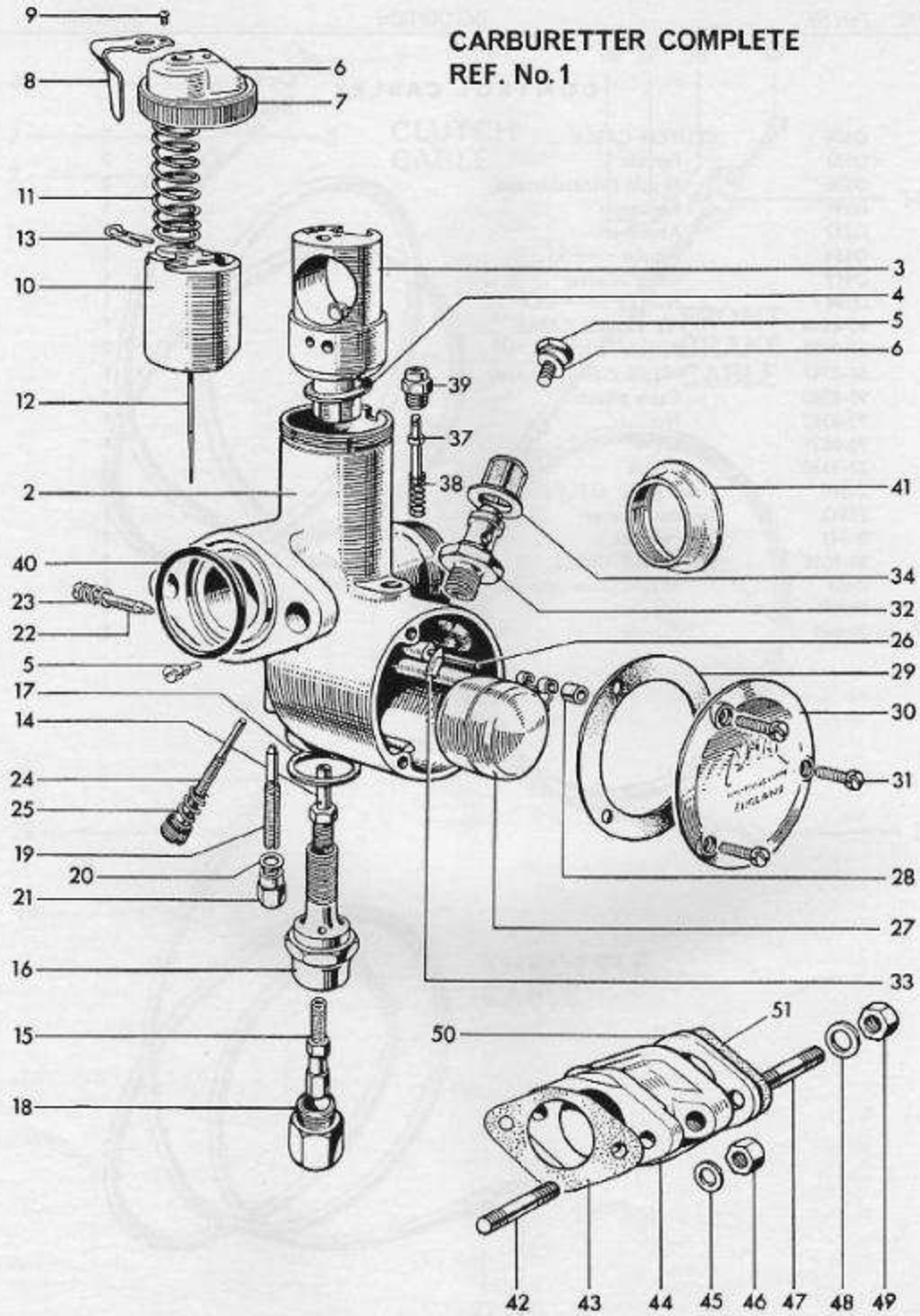

Fig. 22. AMAL CARBURETTER, TYPE 375

AMAL CARBURETTER, TYPE 375

Ref. No.	Part No	DESCRIPTION	QUANTITY
1	375/61	CARBURETTER COMPLETE	1
2	375/003	Mixing chamber	1
3	375/057	Jet block...	1
4	375/067	Joint washer	1
5	376/070	Peg screw	1
6	375/064	Mixing chamber top	1
7	375/065	Cap ring	1
8	4/235	Spring	1
9	4/241	Screw	1
10	375/060	Throttle valve (3½ cutaway)	1
11	375/061	Spring	1
12	375/063	Needle (type B)	1
13	4/230	Clip	1
14	376/073	Needle jet (.105T)	1
15	376/100	Main jet (90)	1
16	376/073	Jet holder	1
17	376/074	Fibre washer	1
18	376/075	Cover nut	1
19	376/076	Pilot jet (25)	1
20	116/162	Fibre washer	1
21	376/095	Cover nut	1
22	332/017	Air adjusting screw	1
23	4/148	Spring	1
24	376/068	Throttle stop screw	1
25	376/069	Spring	1
26	376/085	Float spindle	1
27	376/083	Float	1
28	376/094	Bush	1
29	376/078	Joint washer	1
30	376/077	Cover	1
31	376/079	Screw	1
32	376/088	Needle seating	1
33	376/089	Needle	1
34	376/093	Filter	1
35	376/091	Bolt	1
36	376/092	Fibre washer	1
37	376/086	Tickler	1
38	376/087	Spring	1
39	343/011	Tickler body	1
40	244/765	'O' ring seal	1
41	229/048	Air intake tube	as required
42	E6549	Stud (1 in. O.A.)	2
43	E5902	Joint washer	1
44	E5900	Adaptor	1
45	E2728	Plain washer	2
46	E5269	Self locking nut	2
47	E6550	Stud (1½ in. O.A.)	2
48	S25-3	Plain washer	2
49	S1-51	Nut	2
50	E4504	Insulating block	2
51	NA43	Joint washer	1

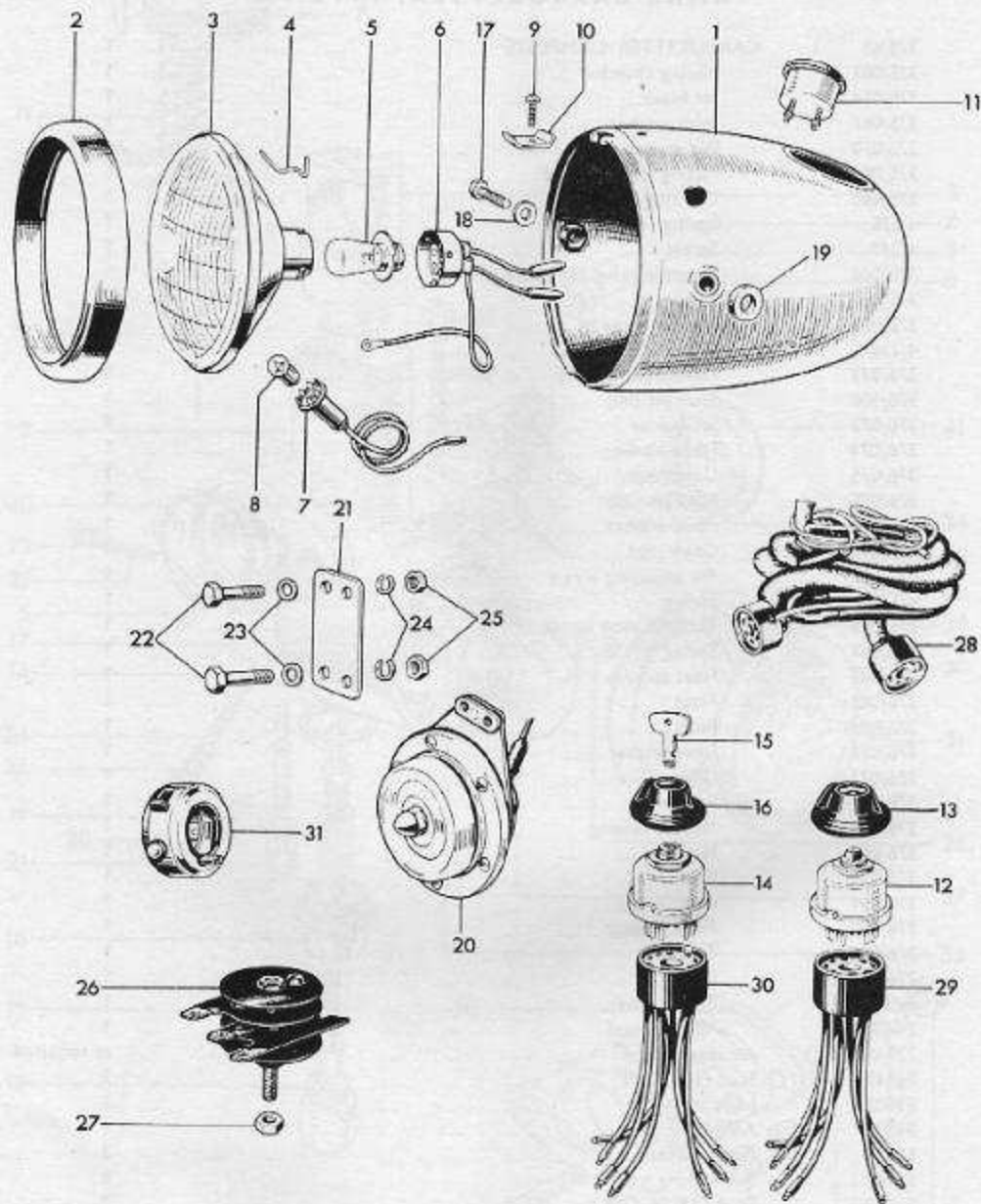

Fig. 23. ELECTRICAL EQUIPMENT

ELECTRICAL EQUIPMENT

Ref. No.	Part No.	DESCRIPTION	QUANTITY
1	59629	HEADLAMP ASSEMBLY, Type MCH 56	1
2	534343	Rim	1
3	516828	Light unit	1
4	504665	Fixing wire	6
5	312	Bulb (30/24W Pre focus)	1
6	554602	Main bulbholder	1
7	554710	Pilot bulbholder	1
8	988	Bulb (3W M.C.C.)	1
9	144921	Screw	1
10	534296	Plate	1
11	36084	Ammeter, type CZU 27	1
12	34289	Lighting switch	1
13	54330934	Knob c/w screw	1
14	34427	IGNITION SWITCH c/w KEYS	1
15	54336176	Key	1
16	54336178	Cover	1
17	112201	Bolt	2
18	137499	Plain washer	2
19	75-5186	Distance piece	2
20	70169	Horn, type 8H	1
21	75-4127	Bracket	1
22	1-4606	Bolt ($\frac{1}{2}$ in. U.H.)	4
23	2-1096	Plain washer	4
24	24-7068	Spring washer	4
25	2-47	Nut	4
26	49072	Rectifier, type 2DS 506	1
27	F5338	Nut	1
28	54939733	WIRING HARNESS...	1
29	54930007	Lighting socket	as required
30	54930008	Ignition socket	as required
31	11519	Horn push and dipper switch	1 Wipac

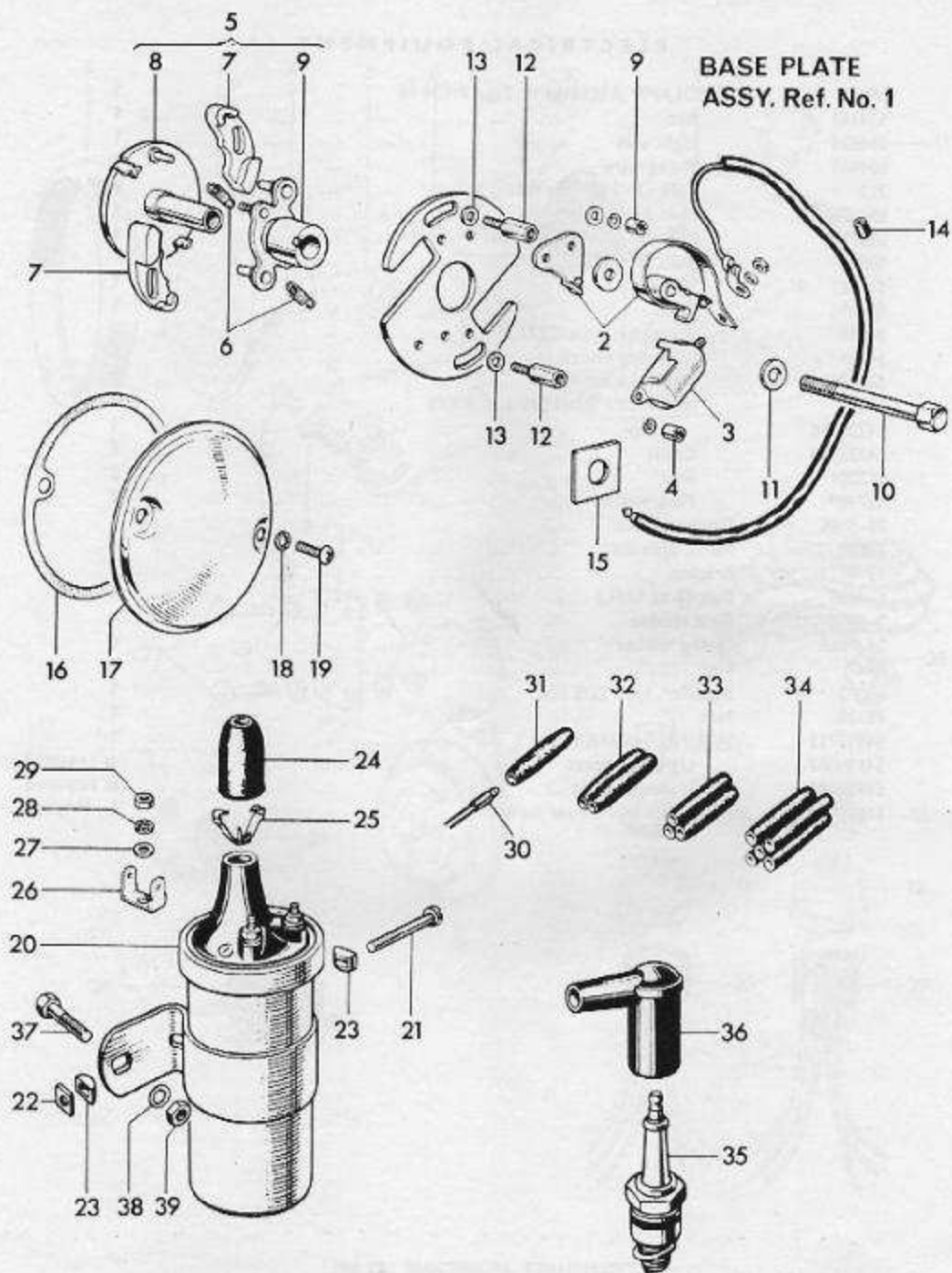

Fig. 24. CONTACT BREAKER AND IGNITION COIL

CONTACT BREAKER AND IGNITION COIL

Ref. No.	Part No.	DESCRIPTION	QUANTITY
1	54415296	CONTACT BREAKER PLATE ASSEMBLY	1
2	54415803	Contact set	1
3	425377	Condenser	1
4	169194	Slotted nut	2
5	54416405	AUTO-ADVANCE UNIT	1
6	54415640	Spring set	1
7	54440031	Weight	2
8	54415749	Sleeve and action plate	1
9	54440602	Cam	1
10	E.5451	Bolt (2 in. U.H.)	1
11	S25-43	Plain washer	1
12	E.4747	Pillar bolt	1
13	E.6559	Plain washer	2
14	E.4750	Grommet	1
15	E.5050	Cable clip	1
16	E.5049	Joint washer	1
17	E.4571	Cover	1
18	GS.299	Serrated washer	2
19	F.4715	Screw ($\frac{1}{2}$ in. U.H.)	2
20	45152	IGNITION COIL, type MA6	1
21	100104	Screw	1
22	169160	Square nut	1
23	422369	'D' washer	2
24	421554	Grommet	1
25	421863	Cable clip	1
26	54190108	Lucar terminal	2
27	131023	Plain washer (E.2351)	2
28	188330	Serrated washer (GS.299)	2
29	166043	Nut (F.3799)	2
30	900269	Snap connector terminal	as required
31	900288	Single snap connector	as required
32	850641	Double snap connector	as required
33	850844	Triple snap connector	as required
34	850832	Quintuple snap connector	as required
35	L7	Sparking plug	1
36	D297	Plug cover and suppressor	1
37	DS57	Bolt ($\frac{7}{16}$ in. U.H.)	2
38	S26-2	Spring washer	2
39	F879	Nut	2

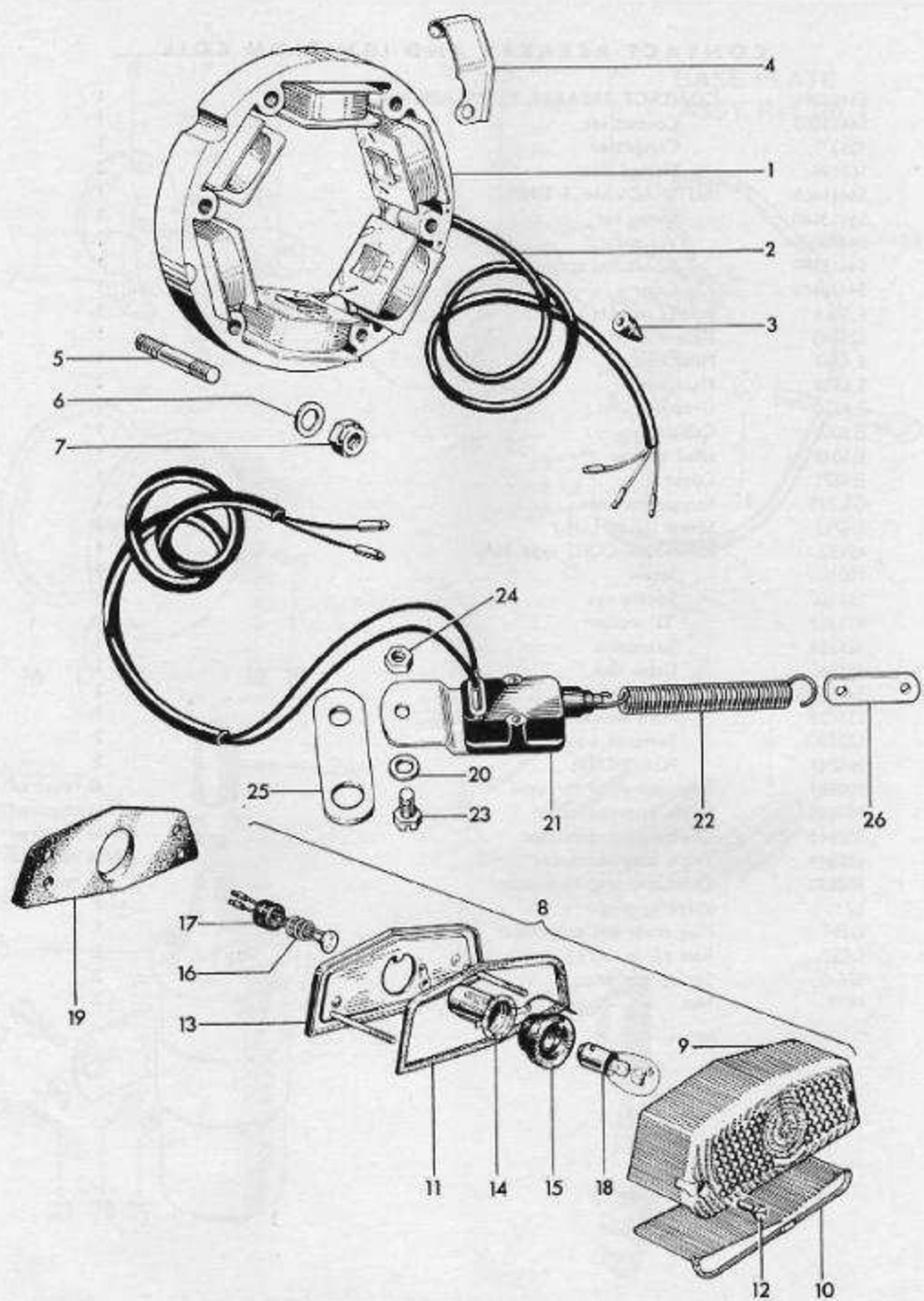

Fig. 25. STATOR, TAIL LAMP AND STOP LAMP SWITCH

Ref. No. Part No.

DESCRIPTION

QUANTITY

STATOR, TAIL LAMP AND STOP LAMP SWITCH

Ref. No.	Part No.	DESCRIPTION	QUANTITY
1	47161	STATOR, Type RM18	1
2	54942271	Stator output cable	1
3	D455	Grommet	1
4	E4485	Clip	1
5	E3171	Stud (1 5/8 in. O.A.)	5
6	E3302	Plain washer	4
7	E5269	Self locking nut	5
8	53394	STOP AND TAIL LAMP, Type 564	1
9	573839	Lens	1
10	575200	Window	1
11	575208	Lens seating gasket	1
12	575219	Sleeve nut	2
13	576002	Base assembly	1
14	574209	Bulbholder	1
15	575207	Grommet	1
16	573828	Contact assembly	1
17	573825	Grommet	1
18	352	Bulb (3/18W offset pin)	1
19	F6437	Adaptor wedge	1
20	E1612	Serrated washer	1
21	12101	Stop lamp switch and lead	1 Wipac
22	315738	Spring	1
23	DS57	Bolt (1/8 in. U.H.)	1
24	F879	Nut	1
25	90-9281	Bracket	1
26	42-9027	Link	1

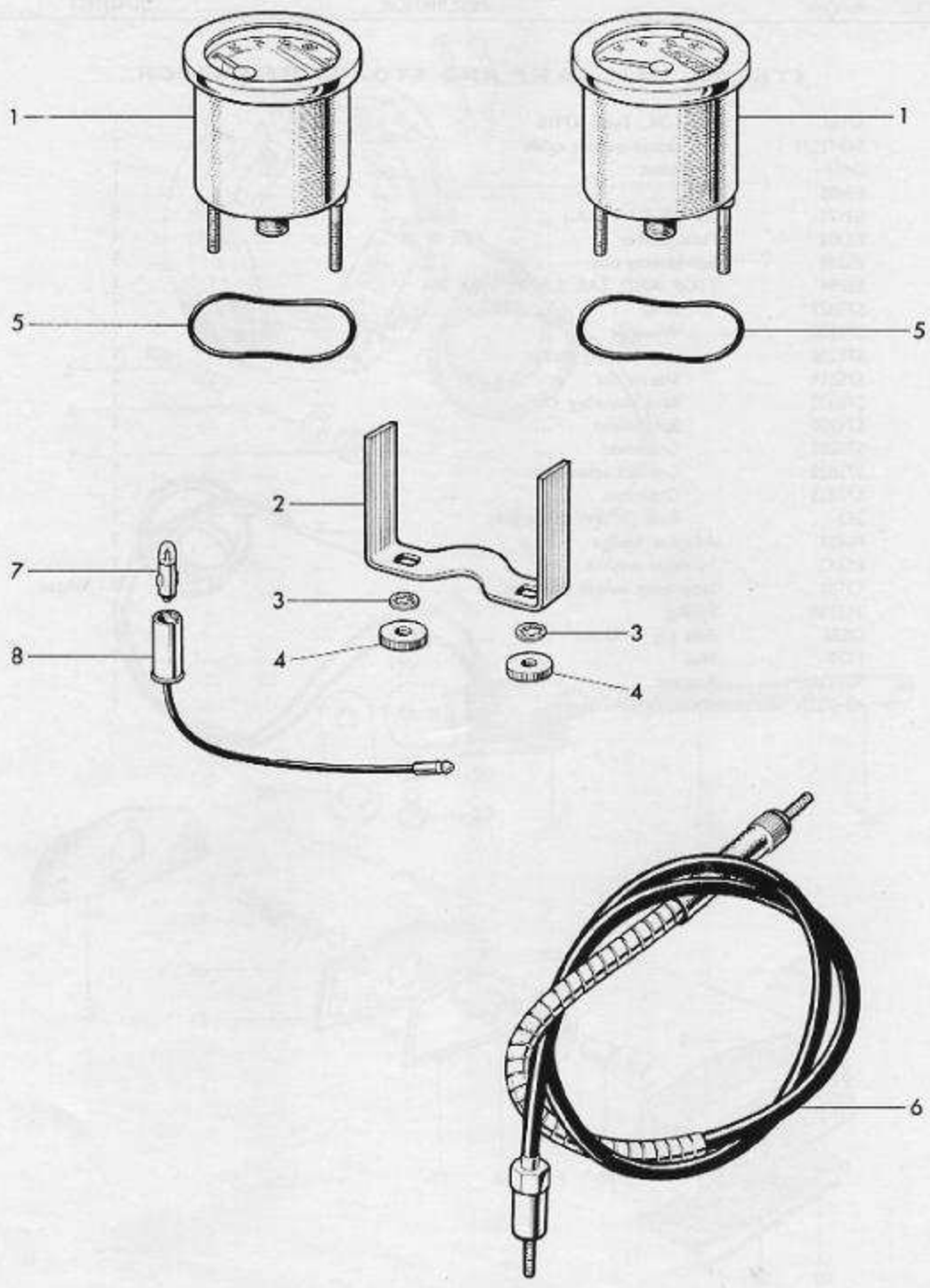

Fig. 26. SPEEDOMETER

Ref. No.	Part No.	DESCRIPTION	QUANTITY
----------	----------	-------------	----------

SPEEDOMETER

1	SSM2001/00	Speedometer 80 MPH	1
1	SSM2001/03	Speedometer 140 Km.P.H.	A
2	31-647-187-01	Fixing strap	1
3	30-283-014-11	Serrated washer	2
4	30-271-014-11	Nut	2
5	31-753-720-	Rubber ring	1
6	90-9316	Speedometer cable (4 ft. 10 in. long)	1
7	282	Bulb 0.6.W. BA7S	1
8	54935300	Bulbholder	1