

# **TRIUMPH**

## **tiger cub**

**TIGER CUB SPORTS MODELS**

# **REPLACEMENT PARTS CATALOGUE No. I**

TIGER CUB  
'A' RANGE MODELS  
T20SM  
T20SH

from Engine No. 101

September 1965

**TRIUMPH ENGINEERING COMPANY LIMITED**  
**MERIDEN WORKS · ALLESLEY · COVENTRY · ENGLAND**  
**TELEPHONE MERIDEN 331** **TELEGRAMS "TRUSTY, COVENTRY"**

## HOW TO USE THIS PARTS CATALOGUE

First check that the engine number of your machine is subsequent to that quoted on the title page.

Next consult the indices on Pages 5 and 6 for the parts or group of parts which you wish to locate. When you have located the parts on the illustration check the reference number on the facing page and make sure from the end columns that the part you have located does apply to your machine.

List the quantities required as single units; do not ask for "2 pairs" or "3 dozen".

In case of painted items always state the colour required. Painted parts are available only in the colours or alternatives specified for that model of that particular year.

<i>Colour</i>	<i>Suffix letter to Part No.</i>
Black	W.
Grenadier Red	GR.
Alaskan White	AW

Paint is available also in all colours in  $9\frac{3}{4}$  oz. Aerosol cans or 1 gallon tins.

# TRIUMPH GUARANTEE

1. In this Guarantee the word "machine" refers to the motor cycle, scooter, motor cycle combination or sidecar as the case may be, purchased by the Purchaser.
2. In order to obtain the benefit of this Guarantee, the Purchaser must have correctly completed the registration form and returned it to us within fourteen days of the purchase.
3. We will supply, free of charge, a new part in exchange for, or, if we consider repair sufficient, will repair free of charge any part proved within six months of the date of purchase of any new machine, (three months overseas) or within three months of its renewal or repair in the case of a part already renewed or repaired, to be defective by reason of our faulty workmanship or materials. We do not undertake to bear the cost of fitting such new or repaired part or accessory.
4. Any part considered to be defective must be sent to our Works, carriage paid, accompanied by the following information:—
  - (a) Name of purchaser and his address;
  - (b) Date of purchase of machine;
  - (c) Name of dealer from whom the purchase was made;
  - (d) Engine number and model.
5. This Guarantee shall not extend to defects or damage appearing after misuse, neglect, abnormal stress or strain, or the incorporation or affixing of unsuitable attachments or parts and in particular:—
  - (a) Hiring out;
  - (b) Racing and Competitions;
  - (c) Adaptation or alteration of any part or parts after leaving our Works;
  - (d) The attaching of a sidecar in a manner not approved by us or to an unsuitable motor cycle.

This Guarantee shall not extend to machines whose trade mark, name or manufacturing number has been altered or removed, or in which has been used any part not supplied or approved by us, or to tyres, saddles, chains, speedometers, revolution counters and electrical equipment or to parts supplied to the order of the Purchaser and different from our standard specification.
6. Our liability and that of our dealer who sells the machine, shall be limited to that set out in this guarantee, and no other claims including claims for consequential damage or injury to person or property, shall be admissible. All other conditions and warranties statutory or otherwise and whether express or implied are hereby excluded and no guarantee other than that expressly herein contained applies to the machine to which this Guarantee relates or any accessory or part thereof.
7. We reserve the right to modify or deviate from the Published Specification without notice.

## REPAIRS GUARANTEE

1. Whilst the highest standard of workmanship and materials is aimed at, we cannot accept liability for any defects appearing more than three months after the machine, assembly or component has left our Works after being repaired.
2. We will repair or replace at our option free of charge any defective work, materials or parts relating to the repairs carried out by us appearing within that time but shall not be under any further or other liability for any other loss or damage whether direct or consequential and our liability shall be limited to the cost of so making good. We do not undertake to bear the cost of fitting any replacement or repaired part.
3. We do not accept liability in respect of parts of proprietary manufacture, e.g. tyres, saddles, chains, speedometers, revolution counters and electrical equipment which may be used by us in effecting a repair. All other conditions and warranties statutory or otherwise express or implied are hereby excluded.

# TRIUMPH SPARES

**HOW TO ORDER.** Every part is indicated by number, and this should be quoted together with the description. In order to assist customers, dimensions have been given in many cases where parts are similar. Parts where possible have been listed in order of assembly and a number of the illustrations show the assembly order also. With these aids there should be no difficulty in identifying the parts you require. **Always head your order with the engine number, stamped on the front engine lug, together with the prefix letters.**

**WHERE TO OBTAIN.** Triumph Spare Parts can only be obtained from an authorised Triumph Dealer, and we recommend our customers to place their orders with the Triumph Dealer in their district. When parts not usually asked for are required, and for which the Dealer may have to write or obtain specially, the postage or carriage incurred becomes payable.

**Triumph Spares are not supplied to private owners direct from the factory. A list of authorised dealers who stock Triumph spares is published overleaf. If difficulty is experienced in obtaining the required parts, the matter should be taken up directly with the Triumph Spares Department.**

Customers are warned against the risk incurred by purchasing parts that are not of genuine Triumph manufacture. This risk is eliminated if parts are ordered as instructed from recognised Dealers.

**PATTERNS AND PARTS FOR REPAIR.** It is not necessary to send patterns if the part number is quoted. The sending of patterns often delays the order as parcel post or rail takes longer than letter post.

Parts sent to Coventry for repair, replacement, or as patterns should bear the sender's name and address and clear instructions should accompany the parts. In your own interest send a copy of the advice note under separate cover. All parts must be forwarded carriage paid and care should be taken to ensure that all remittances are sent separately and not enclosed with the parts. Fragile units such as cylinders, etc., should always be boxed to avoid damage in transit. Complete machines should have all fitments such as windscreens, driving mirrors, tools, etc., removed by the sender before despatch, as it is impossible for us to accept responsibility in the event of loss in transit. We are always pleased to give estimates for overhauling and repairs, but should an estimate not be accepted, a charge will be made covering cost of dismantling and re-assembling, if carried out.

Communications relating to Parts should be addressed to the SPARES DEPARTMENT and for repairs, guarantee claims and technical advice to the SERVICE DEPARTMENT, Triumph Engineering Co. Ltd., Meriden Works, Allesley, Coventry. In order to facilitate quick reference, the quoting of any number, invoice number or reference from previous communications is essential. Accessories not of our manufacture should be sent direct to the actual makers, whose names and addresses appear below.

## PROPRIETARY GROUP

Ancillary equipment which is fitted to our motor cycles is of the highest quality and is guaranteed by the manufacturers and not by ourselves. Any repairs or claims should be directed to the actual makers or their local agents who will always give owners every possible assistance. The following are the addresses of the various manufacturers:—

### **CARBURETTERS.**

Messrs. Amal Ltd.,  
Holdford Road, Witton, Birmingham, 6.

### **CHAINS.**

Renold Chains Ltd.,  
Wythenshawe, Manchester.

### **ELECTRICAL EQUIPMENT.**

Messrs. J. Lucas Ltd.,  
Gt. Hampton Street, Birmingham, 18.

### **TYRES.**

Dunlop Rubber Co. Ltd.,  
Fort Dunlop,  
Birmingham, 24.

The Avon India Rubber Co. Ltd.,  
Melksham,  
Wiltshire.

### **SPARKING PLUGS.**

Champion Sparking Plug Co. Ltd.,  
Feltham, Middlesex.

### **SPEEDOMETERS.**

Messrs. Smiths Motor Accessories Ltd.,  
Cricklewood Works, London, N.W.2.

### **SUSPENSION UNITS.**

Messrs. Girling Ltd.,  
Birmingham Road, West Bromwich, Staffs.

# ILLUSTRATION INDEX

Fig. No.		Page No.
1	CRANKSHAFT, PISTON AND TIMING GEARS ... ..	12
2	CRANKCASE ... ..	14
3	CYLINDER BARREL AND HEAD ... ..	16
4	OIL PUMP AND CONTROL PEDALS ... ..	18
5	GEARBOX SHAFTS AND GEARS ... ..	20 & 22
6	CLUTCH AND CHAINS ... ..	24
7	FRAME COMPLETE ... ..	26
8	FOOTRESTS, CHAINGUARDS, PROPSTAND ETC. ... ..	28
9	TELESCOPIC FRONT FORK ... ..	30
10	FRONT WHEEL ... ..	32
11	REAR WHEEL ... ..	34
12	MUDGUARDS AND NUMBER PLATES ... ..	36
13	TWINSEAT AND EXHAUST SYSTEM ... ..	38
14	PETROL AND OIL TANKS ... ..	40
15	BATTERY CASE, TOOLBOX AND AIR FILTER ... ..	42
16	HANDLEBARS AND CONTROL LEVERS ... ..	44
17	CONTROL CABLES ... ..	46
18	AMAL CARBURETTER, TYPE 376 ... ..	48
19	ELECTRICAL EQUIPMENT ... ..	50
20	CONTACT BREAKER AND IGNITION COIL ... ..	52
21	STATOR, TAIL LAMP AND STOP LAMP SWITCH ... ..	54
22	SPEEDOMETER AND TACHOMETER EQUIPMENT ... ..	56

# INDEX

	<i>Page</i>		<i>Page</i>
AIR FILTER ... ..	43	MUDGUARDS AND NUMBER PLATES	37
ALTERNATIVE SPROCKETS ... ..	10	OIL PUMP ... ..	19
BATTERY CARRIER ... ..	43	OIL TANK ... ..	41
CARBURETTER ... ..	49	PETROL TANK ... ..	41
CARTON PACKS ... ..	9, 10	PILLION FOOTRESTS ... ..	29
CENTRE STAND ... ..	27	PISTONS ... ..	13
CHAINGUARDS ... ..	29	PROP STAND ... ..	29
CHAINS ... ..	25	REAR WHEEL ... ..	35
CLUTCH ... ..	25	RECTIFIER ... ..	51
COIL ... ..	53	ROTOR ... ..	13
CONTACT BREAKER ... ..	53	SILENCERS ... ..	39
CONTROL CABLES ... ..	47	SPARKING PLUGS ... ..	53
CONTROL LEVERS ... ..	45	SPEEDOMETER ... ..	57
CRANKCASE ... ..	15	STATOR ... ..	55
CRANKSHAFT ... ..	13	STEERING RACES ... ..	27
CYLINDER BARREL AND HEAD ... ..	17	SUSPENSION UNITS ... ..	27
ELECTRICAL EQUIPMENT ... ..	51, 53, 55	SWITCHES ... ..	51
ENGINE BOLTS ... ..	27	TACHOMETER ... ..	57
ENGINE SPROCKET ... ..	13	TIMING GEARS ... ..	13
EXHAUST PIPES ... ..	39	TOOLBOX AND TOOLKIT ... ..	43
FOOTRESTS ... ..	29	TWINSEAT ... ..	39
FRAME ... ..	27	TWISTGRIP ... ..	45
FRONT FORKS ... ..	31	VALVES ... ..	17
FRONT WHEEL ... ..	33	WIRING HARNESS ... ..	51
GASKET SETS ... ..	10		
GEARBOX ... ..	21, 23		
HANDLEBARS ... ..	45		
HORN ... ..	51		



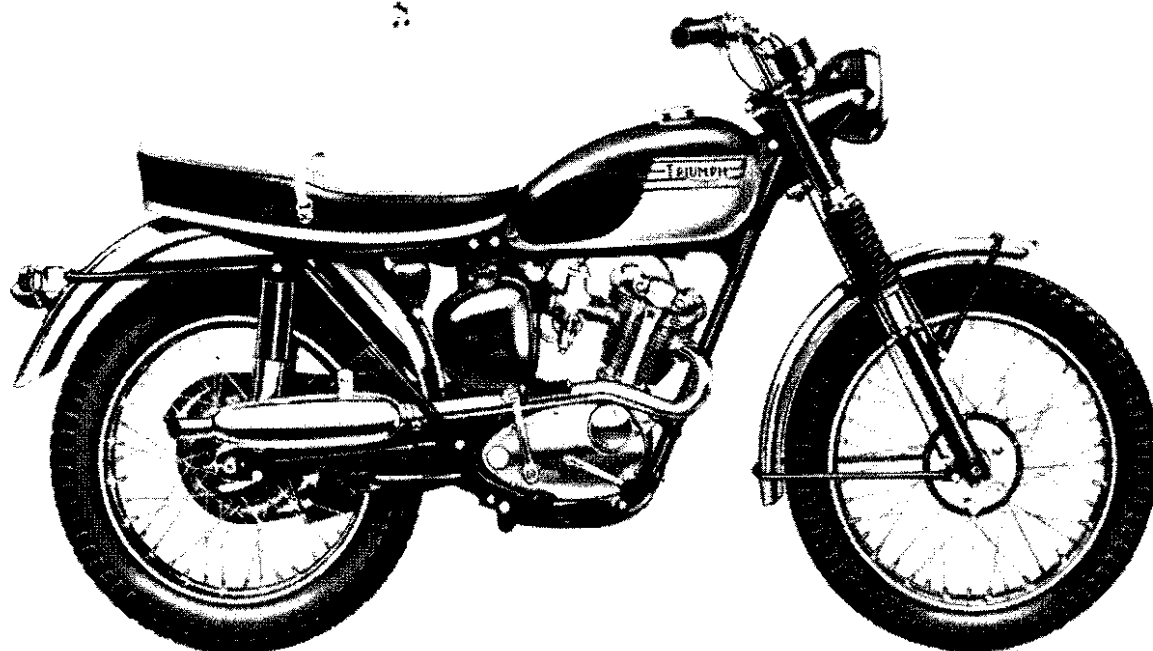

### TIGER CUB (T20SM) TECHNICAL DATA

Bore and Stroke		63 x 64 mm. 2.480 x 2.520 ins.
Capacity		199 c.c. (12 cu. ins.)
Compression Ratio		7 : 1
Sparking Plug	Champion L7	
Carburetter		Amal Monobloc
	Choke Size	$\frac{1}{16}$ in.
	Main Jet	140
	Needle Jet	.105
	Needle	Type C
	Throttle Valve	$37\frac{6}{16}/2\frac{1}{2}$
	Pilot Jet	15
Gearbox Sprocket		17 teeth
Final Drive Sprocket		54 teeth
Chains	Front	$\frac{3}{8}$ in. x $\frac{7}{32}$ in. Duplex x 62 links
	Rear	$\frac{1}{2}$ in. x $\frac{3}{16}$ in. x 117 links
Capacities	Fuel Tank	$2\frac{5}{8}$ galls. (11.9 litres)
	Oil Tank	$2\frac{3}{4}$ pints (1.55 litres)
	Gearbox	$\frac{1}{3}$ pint (190 c.c.)
	Primary Chaincase	$\frac{1}{3}$ pint (190 c.c.)
	Front Forks (each leg)	$\frac{1}{8}$ pint (190 c.c.)
Brakes	Front and Rear Diameter	$5\frac{1}{2}$ in. (13.97 cm.)
Tyre Size	Front	3.00 x 19
	Rear	3.50 x 18

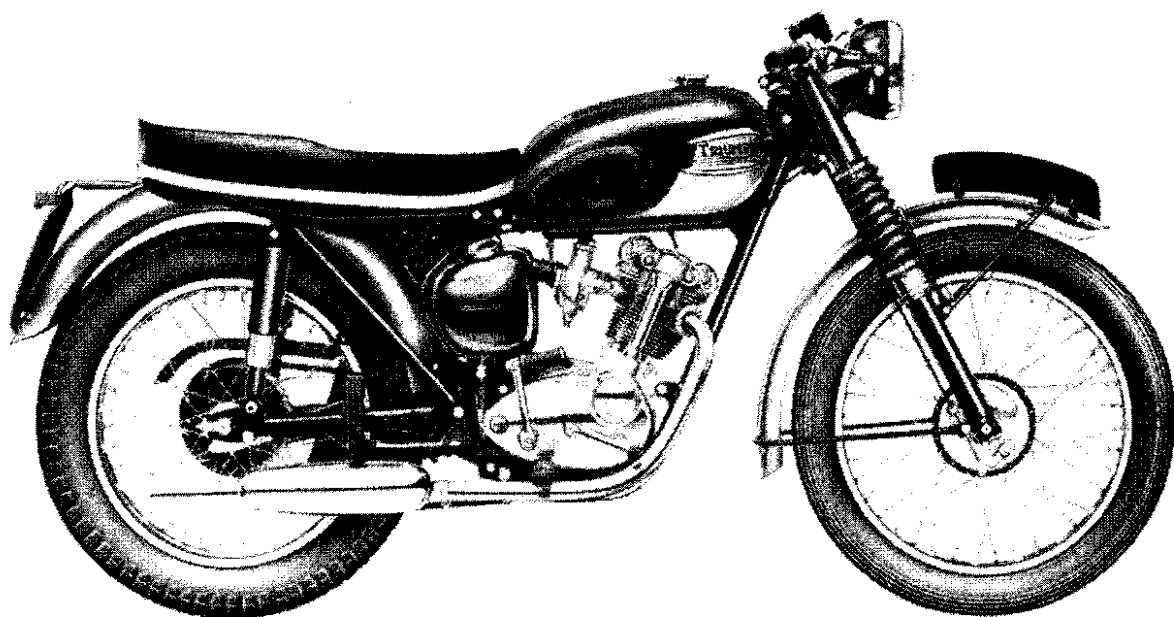

### TIGER CUB (T20SH) TECHNICAL DATA

Bore and Stroke		63 x 64 mm. 2.480 x 2.520 ins.
Capacity		199 c.c. (12 cu. ins.)
Compression Ratio		9 : 1
Sparking Plug	Champion L7	
Carburettor		Amal Monobloc
	Choke Size	$\frac{15}{16}$ in.
	Main Jet	140
	Needle Jet	.106
	Needle	Type C
	Throttle Valve	376/3
	Pilot Jet	20
Gearbox Sprocket		17 teeth
Final Drive Sprocket		48 teeth
Chains	Front	$\frac{3}{8}$ in. x $\frac{7}{32}$ in. Duplex x 62 links
	Rear	$\frac{1}{2}$ in. x $\frac{5}{16}$ in. x 113 links
Capacities	Fuel Tank	3 galls. (13.5 litres)
	Oil Tank	2 $\frac{3}{4}$ pints (1.55 litres)
	Gearbox	$\frac{1}{2}$ pint (190 c.c.)
	Primary Chaincase	$\frac{1}{2}$ pint (190 c.c.)
	Front Forks (each leg)	$\frac{1}{2}$ pint (190 c.c.)
Brakes	Front and Rear Diameter	5 $\frac{1}{2}$ in. (13.97 cm.)
Tyre Size	Front	3.00 x 19
	Rear	3.50 x 18

2



## CARTON PACK LIST

The following sub-assemblies are supplied in carton packs under the C.P. part number stated. The contents of these carton packs are preserved and will not deteriorate under adverse conditions.

Part No.	Contents
<b>Big End Assembly</b>	
C.P. 197	1 E6487      Connecting rod
	1 E5802      Crankpin
<b>Brake Linings</b>	
C.P. 128	2 W978      Brake linings
	14 W979      Rivets
<b>Piston (T20SM)</b>	
C.P. 141	1 E3358      Piston, C.R. 7 : 1
	1 E656      Compression ring (plain)
	1 E3048      Compression ring (taper)
	1 E3387      Oil control ring
	1 E1750      Gudgeon pin
	2 E1767      Circlip
<b>Piston Rings (T20SM)</b>	
C.P. 150	1 E656      Compression ring (plain)
	1 E3048      Compression ring (taper)
	1 E3387      Oil control ring
<b>Piston (T20SH)</b>	
C.P. 172	1 E3958      Piston, C.R. 9 : 1
	1 E3959      Compression ring (plain)
	1 E3960      Compression ring (taper)
	1 E3961      Oil control ring
	1 E1750      Gudgeon pin
	2 E1767      Circlip
<b>Piston Rings (T20SH)</b>	
C.P. 178	1 E3959      Compression ring (plain)
	1 E3960      Compression ring (taper)
	1 E3961      Oil control ring
<b>Valve Guides</b>	
C.P. 122	2 E3208      Valve guide
	2 E3209      Circlip
<b>Valves</b>	
C.P. 186	1 E3963      Inlet valve
	1 E3147      Exhaust valve

**CARTON PACK LIST — continued**

<i>Part No.</i>			<i>Contents</i>
<hr/>			
<b>Valve Springs</b>			
C.P. 185	2	E5975	Inner valve spring
	2	E3966	Outer valve spring
<b>Steering Races</b>			
C.P. 129	2	H835	Cup
	2	H833	Cone
	30	S70-3	Steel ball ( $\frac{1}{4}$ in. diam.)
<hr/>			
<b>Gasket Set</b>	GS	T20/59	All models
<b>De-Coke Gasket Set</b>	D/GS	3	All models
<hr/>			

**ALTERNATIVE SPROCKETS**

<b>Gearbox</b>		<b>Rear Wheel</b>	
T1555/13	13 teeth	W1320	46 teeth
T1555/14	14 teeth	W984	48 teeth
T1555/15	15 teeth	W1074	50 teeth
T1513/16	16 teeth	W1075	52 teeth
T1513/17	17 teeth	W1076	54 teeth
T1513/18	18 teeth	W1078	58 teeth
T1568	19 teeth		

**WORKSHOP TOOLS**

Z 135	Distributor Gear Extractor
Z 139	Timing Pinion Extractor
D 485	Contact Breaker Extractor
D 486	Contact Breaker Reassembly Pilot
D 400	Clutch Extractor
D 538	Flywheel Tool
D 220	Fork Spanner
D 526	Crankshaft bearing extractor tool
D 527	Fork Spanner (for dust excluder sleeve nuts)

### **P L E A S E   N O T E**

THROUGHOUT THIS LIST, ASSEMBLIES ARE PRINTED IN CAPITALS AND THE COMPONENTS INCLUDED IN THAT ASSEMBLY ARE INDENTED IN THE DESCRIPTION COLUMN, REVERTING TO THE ORIGINAL ALIGNMENT WHEN THE ASSEMBLY IS COMPLETE. TO ORDER THE COMPLETE ASSEMBLY IT IS NECESSARY ONLY TO QUOTE THE ASSEMBLY NUMBER. ANY COMPONENT PARTS LISTED MAY ALSO BE OBTAINED SEPARATELY, IF REQUIRED.

### **S P E C I A L   W O R K S H O P   T O O L S**

A COMPLETE LIST OF WORKSHOP TOOLS CAN BE MADE AVAILABLE BY EITHER CONTACTING YOUR DEALER OR APPLYING DIRECT TO THE TRIUMPH SERVICE DEPARTMENT. IN MOST CASES THESE TOOLS ARE VERY COSTLY AS THEY ARE MADE ENTIRELY FOR WORKSHOP USE, AND THEREFORE, IT IS NOT RECOMMENDED THAT THE PRIVATE OWNER PURCHASE THE TOOLS IN ORDER TO AID SERVICING THE MACHINE ONCE OR TWICE ONLY. IN THESE CIRCUMSTANCES IT IS FAR MORE ECONOMICAL TO GET IN TOUCH WITH A RECOGNISED DEALER.

CRANKSHAFT ASSY. REF. N° 1

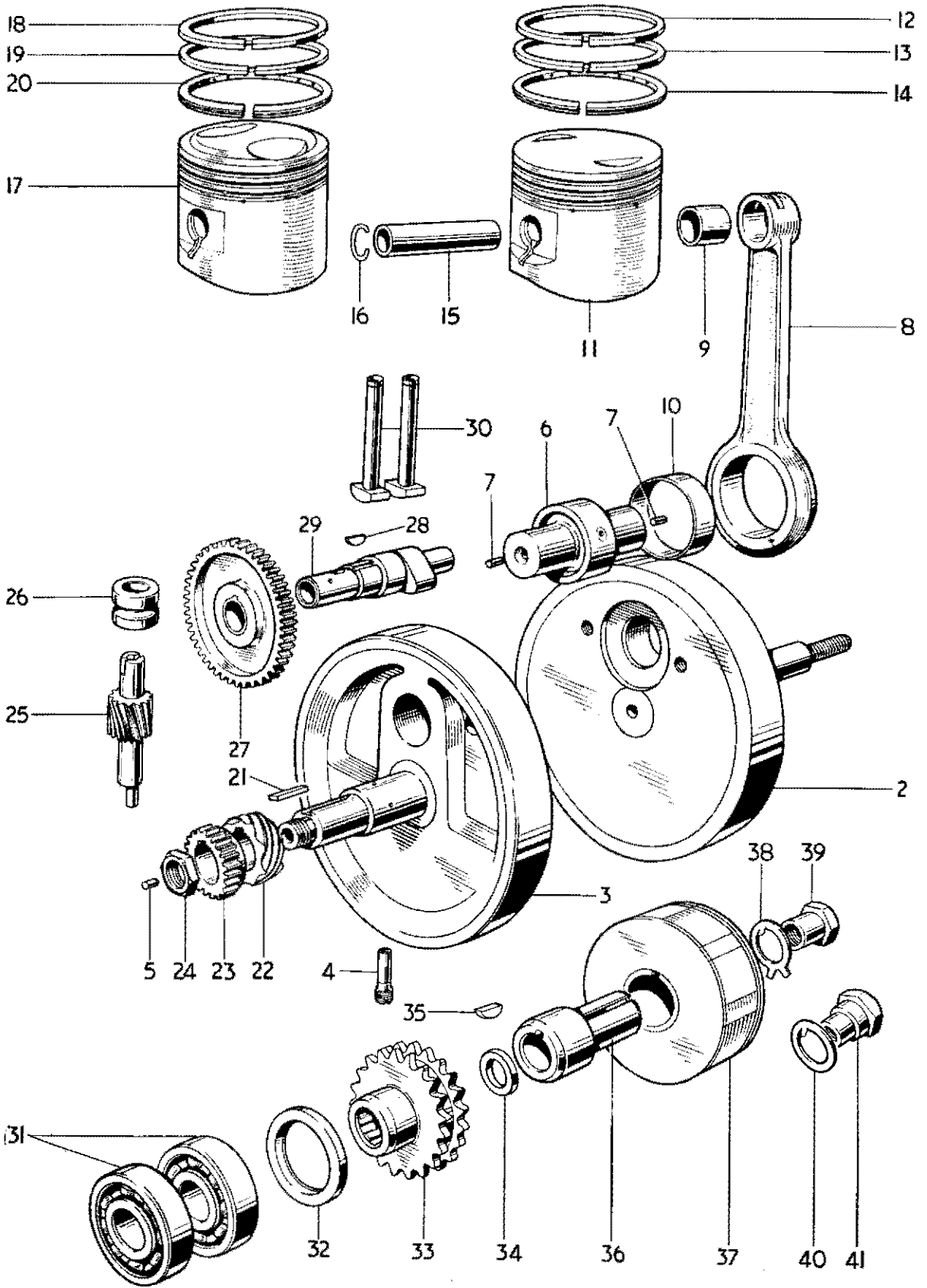

Fig. 1. CRANKSHAFT, PISTON AND TIMING GEARS

### CRANKSHAFT, PISTON AND TIMING GEARS

										T205M	T20SH
1	E6489	CRANKSHAFT ASSEMBLY	...	...	...	...	...	...	...	1	1
2	E4436	Left flywheel ...	...	...	...	...	...	...	...	1	1
3	E5893	RIGHT FLYWHEEL	...	...	...	...	...	...	...	1	1
4	E5806	Screwed plug	...	...	...	...	...	...	...	1	1
5	E3902	Oilway plug	...	...	...	...	...	...	...	1	1
6	E5802	CRANKPIN	...	...	...	...	...	...	...	1	1
7	E3292	Oilway plug	...	...	...	...	...	...	...	2	2
8	E6487	Connecting rod	...	...	...	...	...	...	...	1	1
9	E1762	Small end bush	...	...	...	...	...	...	...	1	1
10	E6488	Big end bush (Export only)	...	...	...	...	...	...	...	1	1
11	CP141	PISTON COMPLETE, C.R. 7 : 1	...	...	...	...	...	...	...	1	-
12	E656	Compression ring	...	...	...	...	...	...	...	1	-
13	E3048	Taper compression ring	...	...	...	...	...	...	...	1	-
14	E3387	Oil control ring	...	...	...	...	...	...	...	1	-
15	E1750	Gudgeon pin	...	...	...	...	...	...	...	1	-
16	E1767	Circlip	...	...	...	...	...	...	...	2	-
17	CP172	PISTON COMPLETE, C.R. 9 : 1	...	...	...	...	...	...	...	-	1
18	E3959	Compression ring	...	...	...	...	...	...	...	-	1
19	E3960	Taper compression ring	...	...	...	...	...	...	...	-	1
20	E3961	Oil control ring...	...	...	...	...	...	...	...	-	1
15	E1750	Gudgeon pin	...	...	...	...	...	...	...	-	1
16	E1767	Circlip	...	...	...	...	...	...	...	-	2
21	E4453	Key	...	...	...	...	...	...	...	1	1
22	E5260	Distributor drive gear	...	...	...	...	...	...	...	1	1
23	E4451	Timing pinion	...	...	...	...	...	...	...	1	1
24	F2725	Nut	...	...	...	...	...	...	...	1	1
25	E5913	Oil pump drive shaft	...	...	...	...	...	...	...	1	1
26	E4693	Oil pump shaft bush...	...	...	...	...	...	...	...	1	1
27	E3185	Camshaft pinion	...	...	...	...	...	...	...	1	1
28	E3184	Camshaft key	...	...	...	...	...	...	...	1	1
29	E6608	Camshaft	...	...	...	...	...	...	...	1	1
30	E3285	Tappet...	...	...	...	...	...	...	...	2	2
31	E3152	Main bearing	...	...	...	...	...	...	...	2	2
32	E3379	Oil seal	...	...	...	...	...	...	...	1	1
33	E3912	Engine sprocket (19 teeth Duplex)	...	...	...	...	...	...	...	1	1
34	E4458	Spacing washer	...	...	...	...	...	...	...	-	1
35	E4455	Key	...	...	...	...	...	...	...	1	1
36	E4454	Adaptor sleeve	...	...	...	...	...	...	...	1	1
37	54213903	Rotor, RM18	...	...	...	...	...	...	...	-	1
37	54213901	Rotor, RM19	...	...	...	...	...	...	...	1	-
38	E4058	Tab washer	...	...	...	...	...	...	...	-	1
39	E3971	Nut	...	...	...	...	...	...	...	-	1
40	E3975	Tab washer	...	...	...	...	...	...	...	1	-
41	E4503	Nut	...	...	...	...	...	...	...	1	-

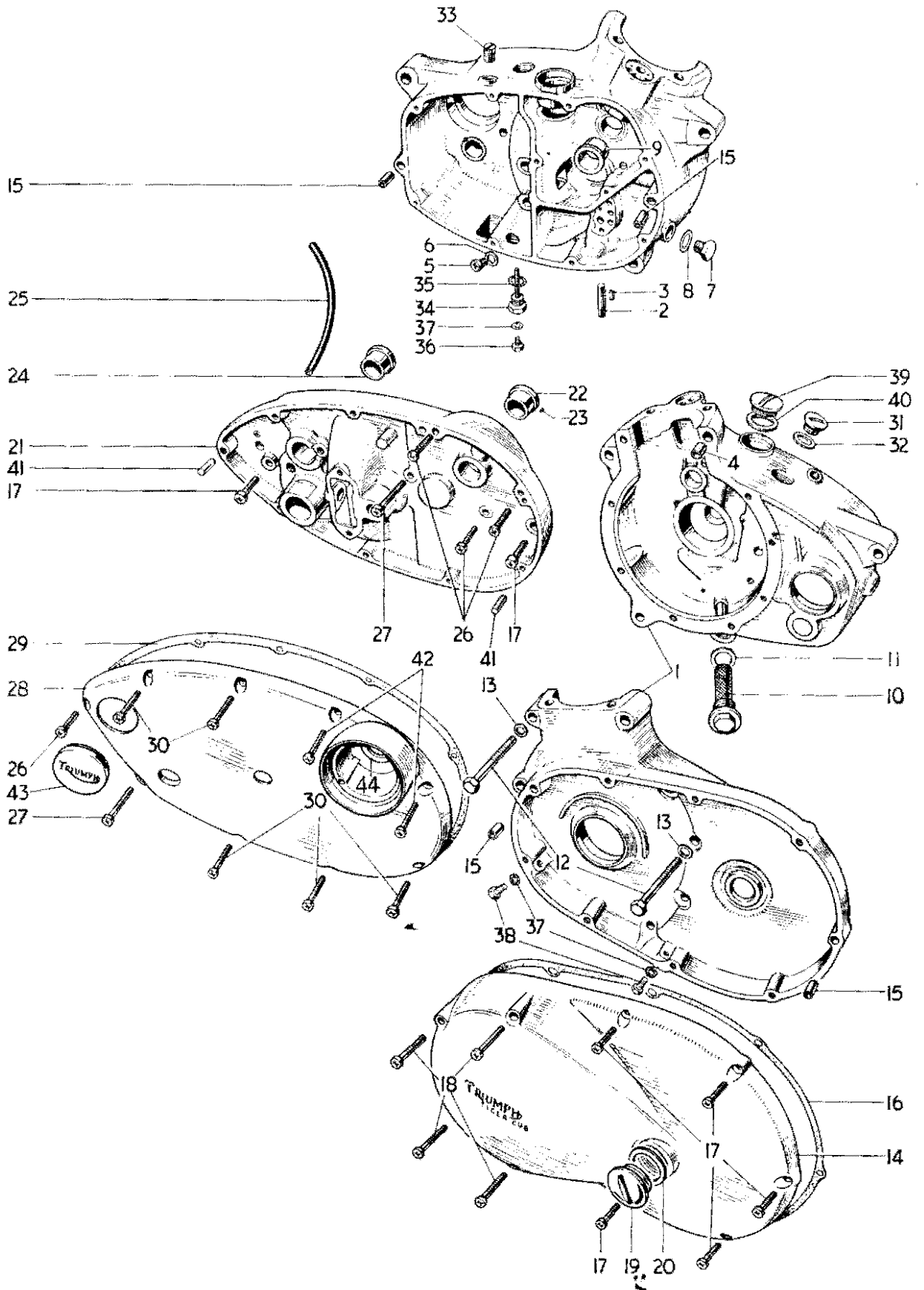

Fig. 2. CRANKCASE

**CRANKCASE**

T20SM T20SH

1	E4087/5908	CRANKCASE	1	1
2	E3171	Oil junction block stud	1	1
3	E3169	Oil junction block dowel	1	1
4	E4121	Hollow dowel	1	1
5	T1553	Screwed plug ( $\frac{3}{8}$ in. U.H.)	1	1
6	E2441	Copper washer	1	1
7	E2615	Screwed plug	1	1
8	E1335	Copper washer	1	1
9	E3175	Camshaft bush	1	1
10	E5456	Crankshaft filter	1	1
11	E2570	Fibre washer	1	1
12	E4098	Bolt ( $1\frac{1}{8}$ in. U.H.)	9	9
13	S25-3	Plain washer	9	9
14	E4089	Left outer cover	1	1
15	T989	Hollow dowel	4	4
16	E4871	Joint washer	1	1
17	E3204	Screw (1 in. U.H.)	7	7
18	E4096	Screw ( $2\frac{3}{8}$ in. U.H.)	4	4
19	E732	Filler plug	1	1
20	NE507	Fibre washer	1	1
21	E4787	RIGHT INNER COVER	1	1
22	E4666	Camshaft bush	1	1
23	E3172	Peg	1	1
24	T1147	Mainshaft bush	1	1
25	F3775	Breather pipe	1	1
26	E3220	Screw ( $1\frac{3}{8}$ in. U.H.)	4	4
27	E3221	Screw ( $1\frac{1}{2}$ in. U.H.)	2	2
28	E4637	Right outer cover	1	1
29	E4872	Joint washer	1	1
30	E3231	Screw ( $1\frac{1}{8}$ in. U.H.)	7	7
31	T1599	Filler plug	1	1
32	E1465	Fibre washer	1	1
33	E4048	Blanking plug	1	1
34	T1112	Drain plug (with level tube)	1	1
35	T1257	Fibre washer	1	1
36	T361	Level plug	1	1
37	WE170	Fibre washer	3	3
38	DS57	Screwed plug	2	2
39	E4587	Blanking plug	1	1
40	E4593	Fibre washer	1	1
41	E4172	Hollow dowel	2	2
42	E4638	Outer cover screw ( $\frac{5}{8}$ in. U.H.)	2	2
43	H1466	Clutch cable access grommet	1	1
44	E4568	Oil seal	1	1





## CYLINDER BARREL AND HEAD

												T20SM	T20SH
1	E6094	Cylinder Barrel	...	...	...	...	...	...	...	...	...	1	1
2	E4037	Cylinder base washer	...	...	...	...	...	...	...	...	...	1	1
3	E3170	Crankcase to cylinder head stud (4 $\frac{1}{2}$ in. O.A.)	...	...	...	...	...	...	...	...	...	4	4
4	E3386	Cylinder head dowel	...	...	...	...	...	...	...	...	...	2	2
5	E6093A	CYLINDER HEAD C/W GUIDES	...	...	...	...	...	...	...	...	...	1	1
6	E3208	Valve guide	...	...	...	...	...	...	...	...	...	2	2
7	E3209	Valve guide circlip	...	...	...	...	...	...	...	...	...	2	2
8	E3207	Exhaust pipe adaptor	...	...	...	...	...	...	...	...	...	1	1
9	E3217	Cylinder head gasket	...	...	...	...	...	...	...	...	...	1	1
10	E5897	Nut	...	...	...	...	...	...	...	...	...	4	4
11	E3446	Plain washer	...	...	...	...	...	...	...	...	...	4	4
12	E3963	Inlet valve	...	...	...	...	...	...	...	...	...	1	1
13	E3147	Exhaust valve...	...	...	...	...	...	...	...	...	...	1	1
14	E5975	Inner valve spring	...	...	...	...	...	...	...	...	...	2	2
15	E3966	Outer valve spring (red)	...	...	...	...	...	...	...	...	...	2	2
16	E5974	Bottom cup	...	...	...	...	...	...	...	...	...	2	2
17	E3301	Top collar	...	...	...	...	...	...	...	...	...	2	2
18	WE259A	Split cotter	...	...	...	...	...	...	...	...	...	4	4
19	E3251	INLET ROCKER	...	...	...	...	...	...	...	...	...	1	1
20	E3252	EXHAUST ROCKER	...	...	...	...	...	...	...	...	...	1	1
21	E3222	Rocker ball pin	...	...	...	...	...	...	...	...	...	2	2
22	E3223	Adjuster pin	...	...	...	...	...	...	...	...	...	2	2
23	GS662	Nut	...	...	...	...	...	...	...	...	...	2	2
24	E3225	Rocker spindle	...	...	...	...	...	...	...	...	...	2	2
25	E3253	Sealing ring	...	...	...	...	...	...	...	...	...	2	2
26	E2534	Thrust washer $\frac{7}{8}$ in.	...	...	...	...	...	...	...	...	...	4	4
27	E3224	Thackeray washer	...	...	...	...	...	...	...	...	...	2	2
28	E2594	Thrust washer $\frac{3}{8}$ in.	...	...	...	...	...	...	...	...	...	2	2
29	E1335	Copper washer $\frac{3}{8}$ in.	...	...	...	...	...	...	...	...	...	2	2
30	E3249	Copper washer $\frac{5}{16}$ in.	...	...	...	...	...	...	...	...	...	2	2
31	H400	Domed nut	...	...	...	...	...	...	...	...	...	2	2
32	E3226	Joint washer	...	...	...	...	...	...	...	...	...	2	2
33	E4648	Inlet rocker cover	...	...	...	...	...	...	...	...	...	1	1
34	E4649	Exhaust rocker cover	...	...	...	...	...	...	...	...	...	1	1
35	E3210	Stud (2 $\frac{5}{8}$ in. O.A.)	...	...	...	...	...	...	...	...	...	2	2
36	E2441	Copper washer	...	...	...	...	...	...	...	...	...	2	2
37	E3290	Self-locking nut	...	...	...	...	...	...	...	...	...	2	2
38	E3372	Push rod	...	...	...	...	...	...	...	...	...	2	2
39	E3537	Cover tube	...	...	...	...	...	...	...	...	...	1	1
40	E3391	Lower joint washer	...	...	...	...	...	...	...	...	...	1	1
41	E3540	Upper joint washer	...	...	...	...	...	...	...	...	...	1	1

OIL PUMP ASSEMBLY REF. N°1

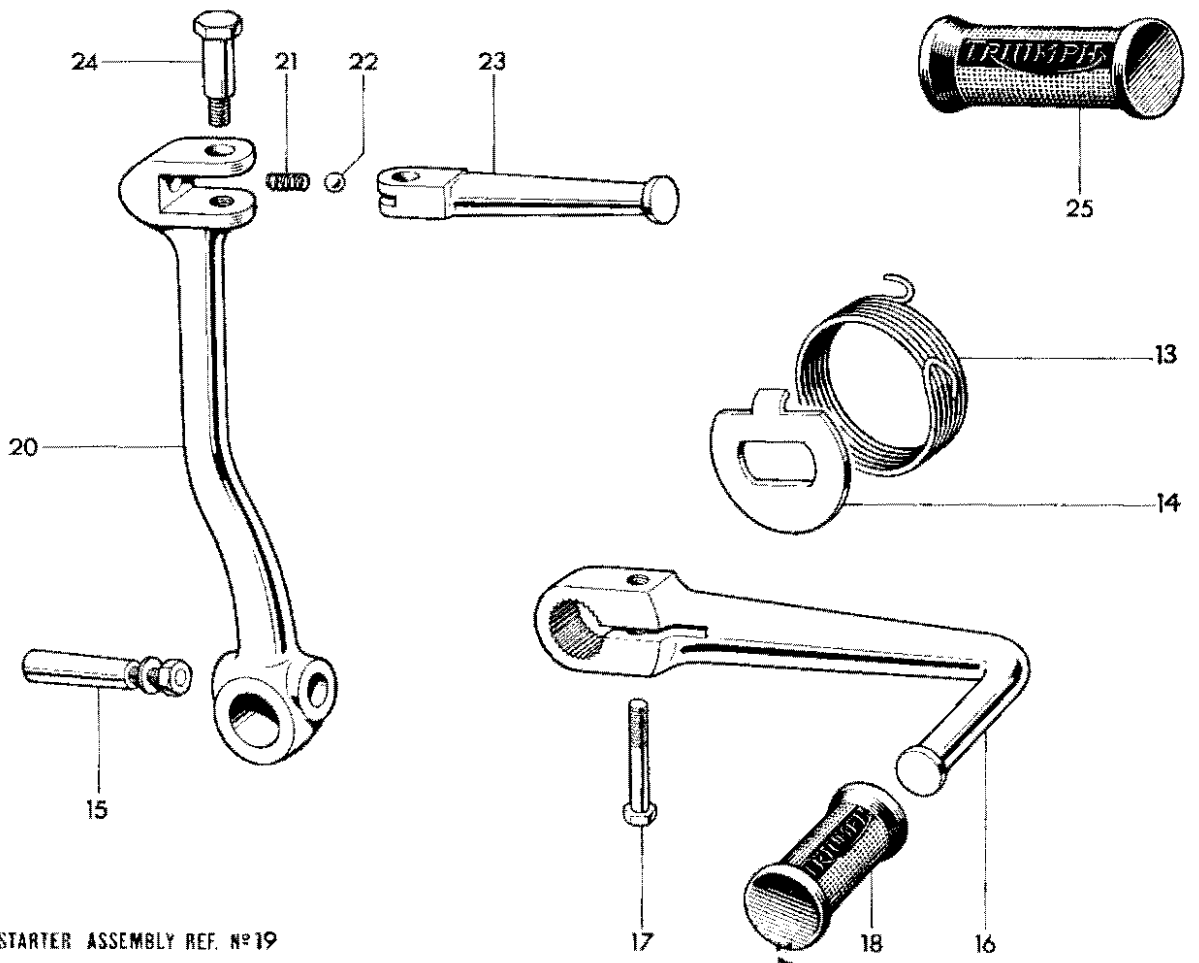
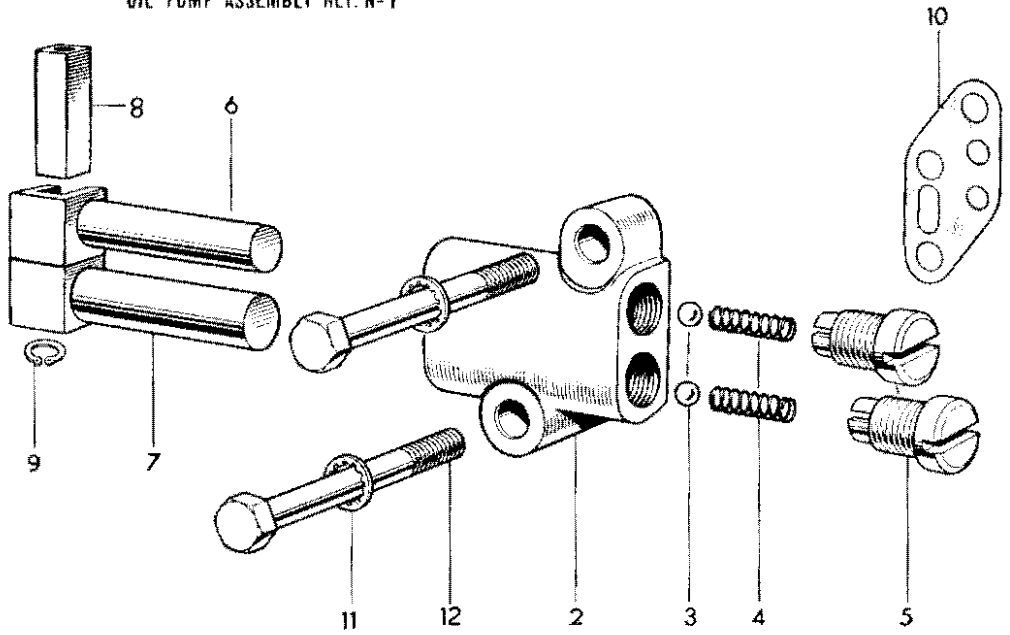

KICKSTARTER ASSEMBLY REF. N°19

Fig. 4. OIL PUMP AND CONTROL PEDALS

### OIL PUMP AND CONTROL PEDALS

			T20SM	T20SH
1	E6486	OIL PUMP ASSEMBLY ... ..	1	1
2	E5909	Pump body ... ..	1	1
3	S70-4	Steel ball ( $\frac{3}{16}$ in. diam.) ... ..	2	2
4	E4404	Spring ... ..	2	2
5	E4212	Plug ... ..	2	2
6	E5910	Feed plunger ... ..	2	2
7	E5911	Scavenge plunger ... ..	1	1
8	E5912	Drive block ... ..	1	1
9	E6474	Circlip... ..	1	1
10	E3188	Joint washer ... ..	1	1
11	GS299	Serrated washer ... ..	2	2
12	E3197	Bolt ( $\frac{1}{8}$ in. U.H.) ... ..	2	2
13	T1162	Kickstarter return spring ... ..	1	1
14	T1163	Return spring plate ... ..	1	1
15	T1222	Cotter pin c/w nut and washer ... ..	1	1
16	T1164	Gearchange pedal ... ..	1	1
17	F1369	Bolt ( $\frac{5}{8}$ in. U.H.) ... ..	1	1
18	T449	Pedal rubber ... ..	1	1
19	T1679	KICKSTARTER ASSEMBLY ... ..	1	1
20	T1680	Crank ... ..	1	1
21	T1167	Spring ... ..	1	1
22	S70-3	Steel ball ( $\frac{1}{4}$ in. diam.) ... ..	1	1
23	T2070	Pedal ... ..	1	1
24	T1169	Pivot bolt ... ..	1	1
25	F1814	Pedal rubber ... ..	1	1

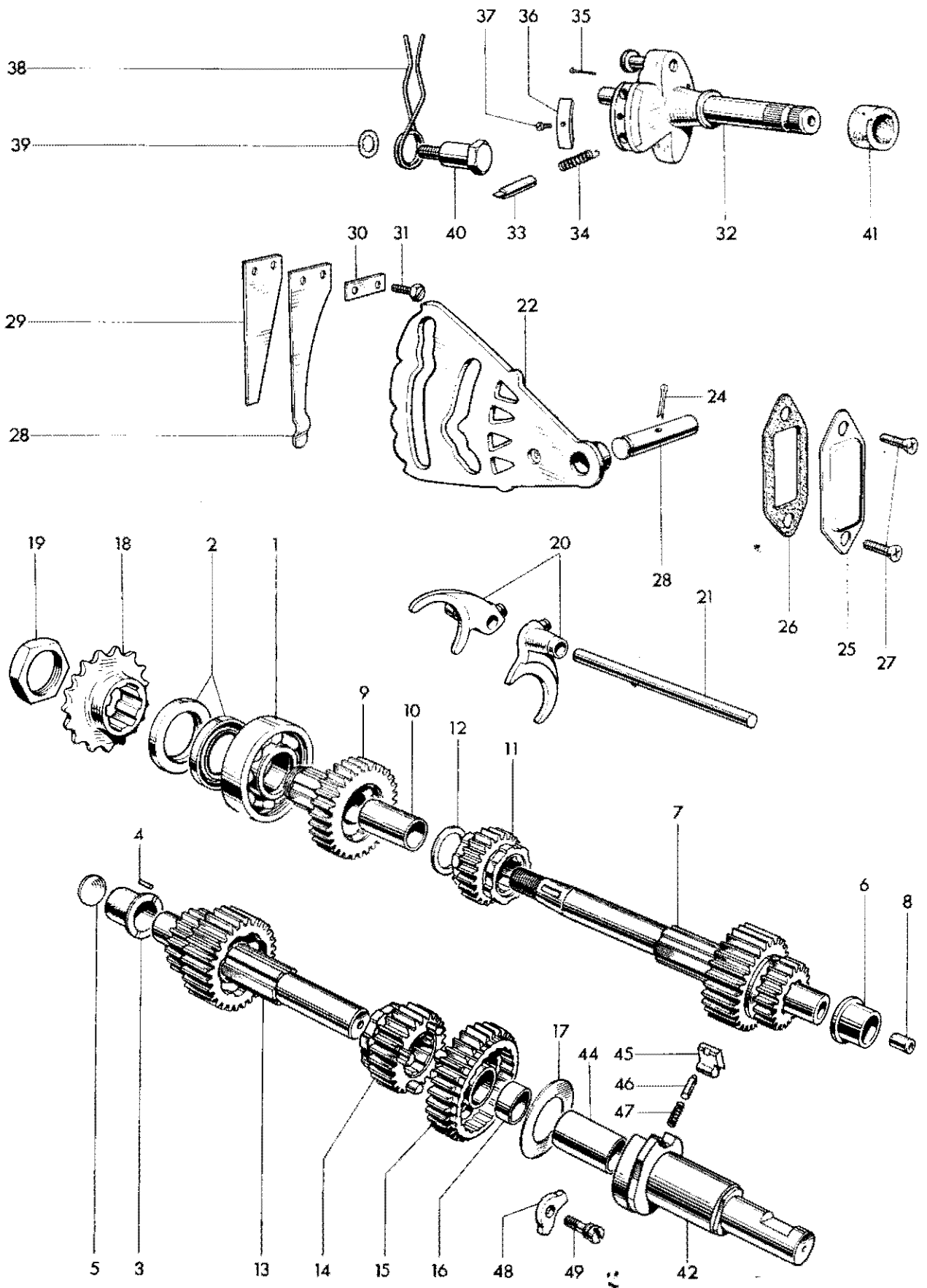

Fig. 5. GEARBOX SHAFTS AND GEARS

Ref. No.	Part No.	DESCRIPTION	QUANTITY	
			T20SM	T20SH
<b>GEARBOX SHAFTS AND GEARS</b>				
1	T1070	High gear bearing ... ..	1	1
2	H1168	Oil seal ... ..	2	2
3	T1073	Layshaft bearing bush ... ..	1	1
4	E3172	Peg ... ..	1	1
5	T1269	Blanking disc ... ..	1	1
6	T1147	Mainshaft bush ... ..	1	1
7	T1588	MAINSHAFT CLUSTER ... ..	1	1
8	T1085	Clutch rod bush ... ..	1	1
9	T1596	HIGH GEAR (29T) W.R. ... ..	1	-
9	T1565	HIGH GEAR (27T) C.R. ... ..	-	1
10	T1515	High gear bush ... ..	1	1
11	T1089	Mainshaft second gear ... ..	1	1
12	T1090	Mainshaft thrust ring ... ..	1	1
13	T1728	Layshaft cluster (16T) W.R. ... ..	1	-
13	T1594	Layshaft cluster (18T) C.R. ... ..	-	1
14	T1094	Layshaft third gear ... ..	1	1
15	T1095	LAYSHAFT LOW GEAR ... ..	1	1
16	T1097	Low gear bush ... ..	1	1
17	T1274	Pawl retaining disc ... ..	1	1
18	T1513/17	Gearbox sprocket (17 teeth) ... ..	1	1
19	T1082	Sprocket nut ... ..	1	1
20	T1098	Selector fork ... ..	2	2
21	T1102	Selector fork spindle ... ..	1	1
22	T1066	Camplate ... ..	1	1
23	T1069	Camplate spindle ... ..	1	1
24	$\frac{3}{32}$ in. x $\frac{3}{4}$ in.	Split pin ... ..	1	1
25	T1149	Cover plate ... ..	1	1
26	T1148	Joint washer ... ..	1	1
27	T1150	Screw (0.41 in. U.H.) ... ..	2	2
28	T1248	Index spring ... ..	1	1
29	T1249	Supplementary index spring ... ..	1	1
30	T1180	Lockplate ... ..	1	1
31	T1076	Screw ( $\frac{3}{8}$ in. U.H.) ... ..	2	2
32	T2104	GEARCHANGE QUADRANT ... ..	1	1
33	T2105	Plunger ... ..	2	2
34	T2106	Spring ... ..	2	2
35	T1277	Peg ... ..	2	2
36	T2107	Keeper plate ... ..	1	1
37	T1676	Screw ... ..	1	1
38	T1109	Return spring ... ..	1	1
39	E2287	Serrated washer ... ..	1	1
40	T1077	Bolt ... ..	1	1
41	T1181	Felt washer ... ..	1	1

(continued on page 23)

For alternative sprockets see Page 10

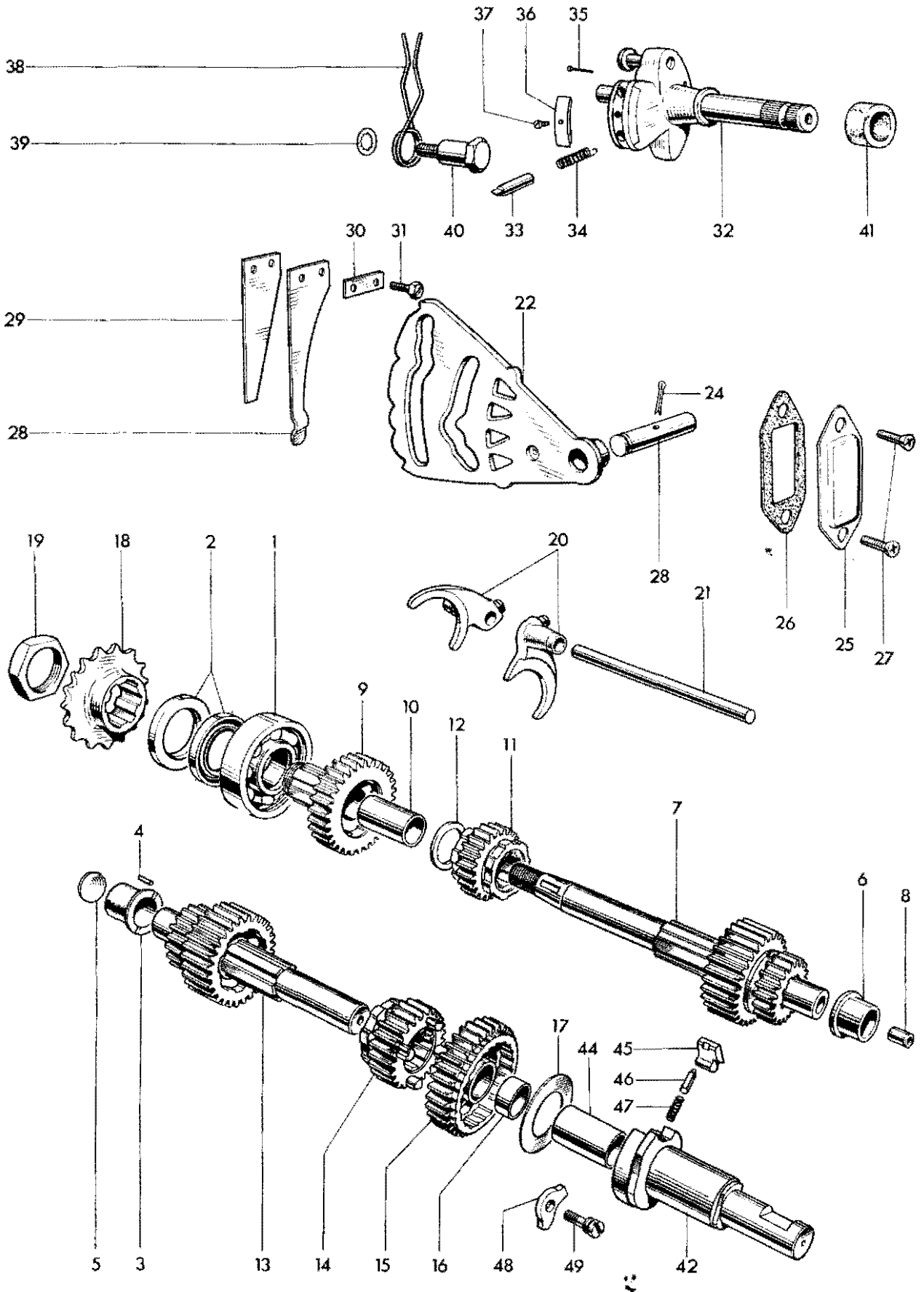

Fig. 5. GEARBOX SHAFTS AND GEARS

**GEARBOX<sup>2</sup> SHAFTS AND GEARS — (continued)**

										T20SM	T20SH
42	T1279	KICKSTARTER SPINDLE	...	...	...	...	...	...	...	1	1
44	T1118	Bush	...	...	...	...	...	...	...	1	1
45	T1281	Pawl	...	...	...	...	...	...	...	1	1
46	T1282	Plunger	...	...	...	...	...	...	...	1	1
47	T1161	Spring	...	...	...	...	...	...	...	1	1
48	T1157	Stop plate	...	...	...	...	...	...	...	1	1
49	T1158	Screw	...	...	...	...	...	...	...	1	1

**EXTRA CLOSE RATIO GEARS**

7	T1819	Mainshaft cluster (E.C.R.)	} Extra close ratio gear set.
9	T1652	Mainshaft high gear (E.C.R.)	
11	T1089	Mainshaft second gear (Std.)	
13	T1657	Layshaft cluster (E.C.R.)	
14	T1659	Layshaft third gear (E.C.R.)	
15	T1095	Layshaft low gear (Std.)	

OPERATING LEVER ASSEMBLY REF. N° 1  
 CLUTCH COMPLETE REF. N° 13

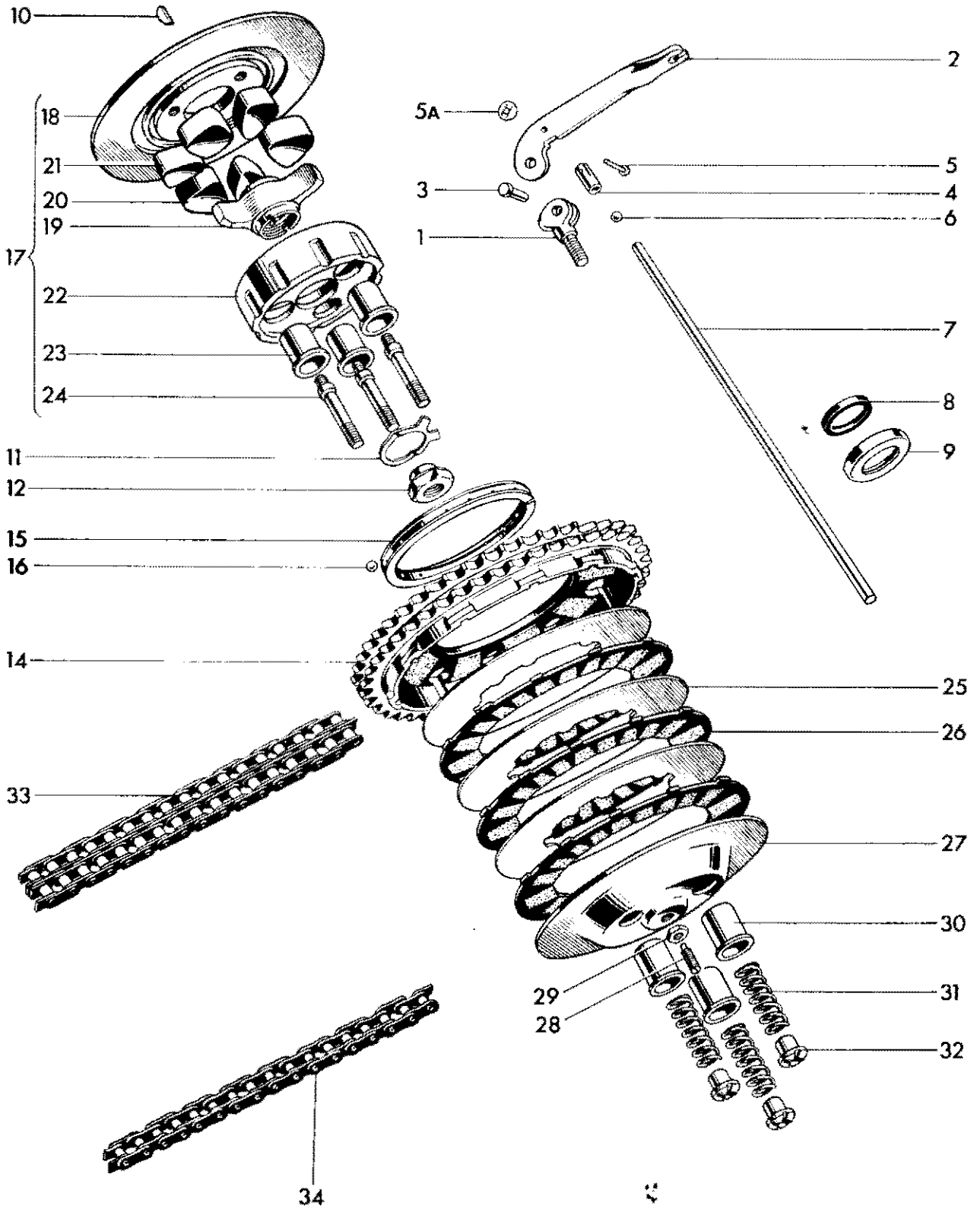

Fig. 6. CLUTCH AND CHAINS



## CLUTCH AND CHAINS

										T20SM	T20SH
1	T2065	CLUTCH OPERATING LEVER ASSEMBLY	...	...	...	...	...	...	...	1	1
2	T2066	Lever	...	...	...	...	...	...	...	1	1
3	T1236	Pin	...	...	...	...	...	...	...	1	1
4	T2067	Cup	...	...	...	...	...	...	...	1	1
5	T2068	Split	...	...	...	...	...	...	...	1	1
5A	T2069	Push fix	...	...	...	...	...	...	...	1	1
6	T1124	Steel ball ( $\frac{5}{32}$ in. diam.)	...	...	...	...	...	...	...	1	1
7	T1140	Clutch operating rod	...	...	...	...	...	...	...	1	1
8	E3932	Mainshaft oil seal	...	...	...	...	...	...	...	1	1
9	E3933	Oil seal retainer	...	...	...	...	...	...	...	1	1
10	T1119	Key	...	...	...	...	...	...	...	1	1
11	T1347	Tab washer	...	...	...	...	...	...	...	1	1
12	T1348	Nut	...	...	...	...	...	...	...	1	1
13	T1924	CLUTCH COMPLETE	...	...	...	...	...	...	...	1	1
14	T1509	Sprocket and housing (48 teeth)	...	...	...	...	...	...	...	1	1
15	T1264	Bearing ring	...	...	...	...	...	...	...	1	1
16	T1124	Steel ball ( $\frac{5}{32}$ in. diam.)	...	...	...	...	...	...	...	16	16
17	T1667	SHOCK ABSORBER	...	...	...	...	...	...	...	1	1
18	T1668	Back plate	...	...	...	...	...	...	...	1	1
19	T1346	Spider	...	...	...	...	...	...	...	1	1
20	T1132	Drive rubber (large)	...	...	...	...	...	...	...	3	3
21	T1318	Rebound rubber (small)	...	...	...	...	...	...	...	3	3
22	T1314	Centre	...	...	...	...	...	...	...	1	1
23	T1669	Cup	...	...	...	...	...	...	...	3	3
24	T1670	Pin	...	...	...	...	...	...	...	3	3
25	T1315	Driven plate	...	...	...	...	...	...	...	3	3
26	T1503	Driving plate c/w linings	...	...	...	...	...	...	...	3	3
27	T1925	Pressure plate	...	...	...	...	...	...	...	1	1
28	T2064	Adjuster	...	...	...	...	...	...	...	1	1
29	GS662	Nut	...	...	...	...	...	...	...	1	1
30	T1927	Cup	...	...	...	...	...	...	...	3	3
31	T1742	Spring	...	...	...	...	...	...	...	3	3
32	T1146	Nut	...	...	...	...	...	...	...	3	3
33	D382	Primary chain ( $\frac{3}{8}$ in. Duplex x 62 links)	...	...	...	...	...	...	...	1	1
34	D554	Rear chain ( $\frac{1}{2}$ in. x $\frac{1}{8}$ in. x 117 links)	...	...	...	...	...	...	...	1	-
34	D430	Rear chain ( $\frac{1}{2}$ in. x $\frac{1}{8}$ in. x 113 links)	...	...	...	...	...	...	...	-	1

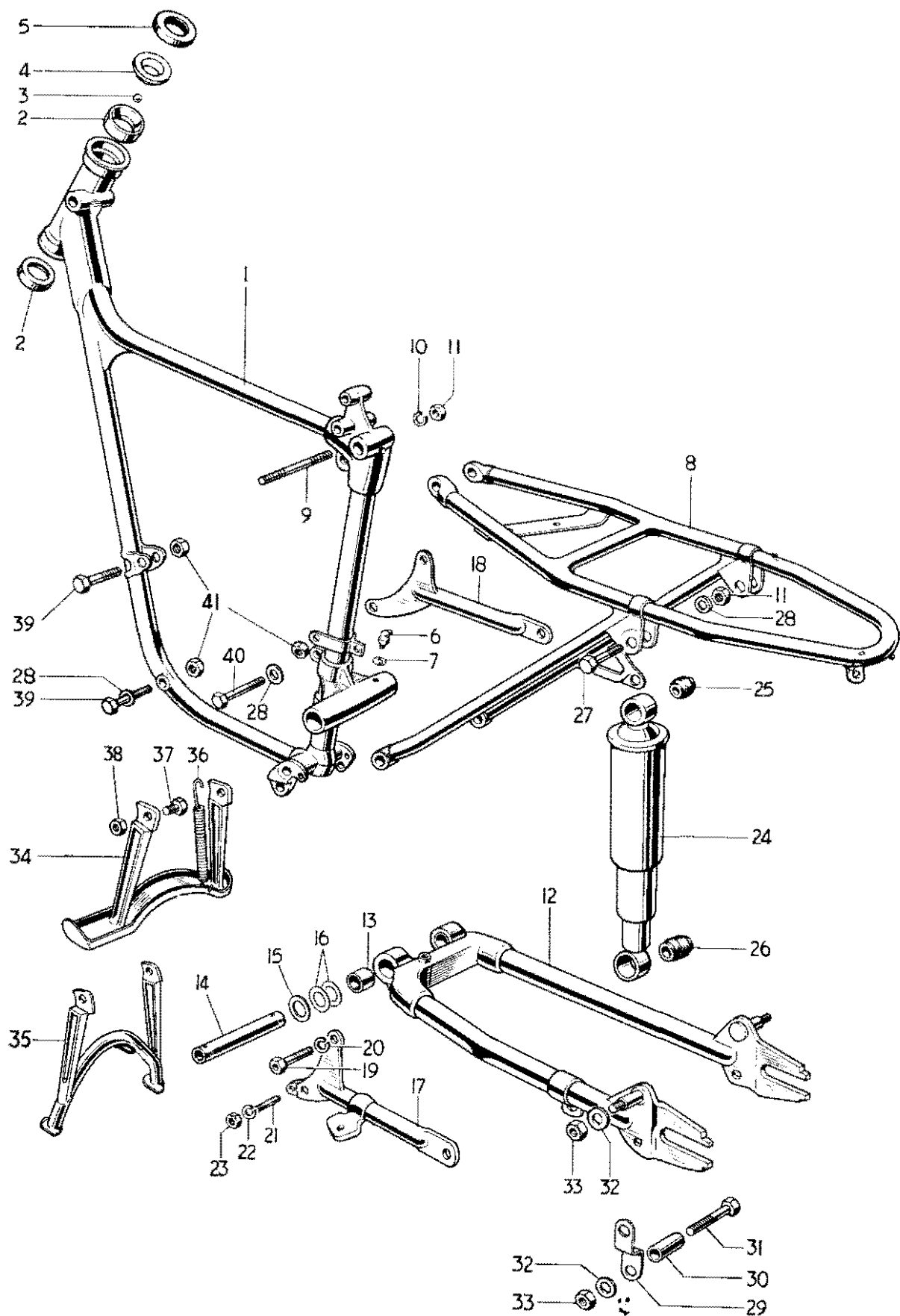

Fig. 7. FRAME COMPLETE

**FRAME COMPLETE**

											T20SM	T20SH
1	F4594	Front Frame ... ..	...	...	...	...	...	...	...	...	-	1
1	F5191	Front frame ... ..	...	...	...	...	...	...	...	...	1	-
2	H835	Steering race cup ... ..	...	...	...	...	...	...	...	...	2	2
3	S70-3	Steel ball ( $\frac{1}{4}$ in. diam.) ... ..	...	...	...	...	...	...	...	...	30	30
4	H833	Top cone ... ..	...	...	...	...	...	...	...	...	1	1
5	H836	Dust cover ... ..	...	...	...	...	...	...	...	...	1	1
6	NW100	Grease nipple ... ..	...	...	...	...	...	...	...	...	1	1
7	WE170	Fibre washer ... ..	...	...	...	...	...	...	...	...	1	1
8	F5164	Rear frame ... ..	...	...	...	...	...	...	...	...	1	1
9	E1023	Stud ( $3\frac{5}{8}$ in. O.A.) ... ..	...	...	...	...	...	...	...	...	1	1
10	S26-1	Spring washer ... ..	...	...	...	...	...	...	...	...	2	2
11	P0172A	Nut ... ..	...	...	...	...	...	...	...	...	4	4
12	F6192	SWINGING FORK ... ..	...	...	...	...	...	...	...	...	1	1
13	F4076	Pivot bush ... ..	...	...	...	...	...	...	...	...	2	2
14	F4079	Spindle ... ..	...	...	...	...	...	...	...	...	1	1
15	F4078	Spacing washer ... ..	...	...	...	...	...	...	...	...	1	1
16	F4385	Shim, 0.003 in. ... ..	...	...	...	...	...	...	...	...	as required	
16	F4386	Shim, 0.005 in. ... ..	...	...	...	...	...	...	...	...	as required	
17	F4278	Left bracket ... ..	...	...	...	...	...	...	...	...	1	1
18	F4081	Right bracket ... ..	...	...	...	...	...	...	...	...	1	1
19	F4087	Bolt ( $1\frac{1}{2}$ in. U.H.) ... ..	...	...	...	...	...	...	...	...	2	2
20	PCW73A	Spring washer ... ..	...	...	...	...	...	...	...	...	2	2
21	E1396	Stud ( $1\frac{1}{4}$ in. O.A.) ... ..	...	...	...	...	...	...	...	...	2	2
22	S26-3	Spring washer ... ..	...	...	...	...	...	...	...	...	2	2
23	S1-51	Nut ... ..	...	...	...	...	...	...	...	...	2	2
24	SC3/204	SUSPENSION UNIT ... ..	...	...	...	...	...	...	...	...	-	2
24	64054441	SUSPENSION UNIT ... ..	...	...	...	...	...	...	...	...	2	-
25	9054/316A	Bonded bush ... ..	...	...	...	...	...	...	...	...	2	2
26	9054/316J	Bonded bush ... ..	...	...	...	...	...	...	...	...	2	2
27	F1760	Bolt ( $1\frac{1}{8}$ in. U.H.) ... ..	...	...	...	...	...	...	...	...	-	2
27	E2113	Bolt ( $1\frac{1}{8}$ in. U.H.) ... ..	...	...	...	...	...	...	...	...	2	-
28	S25-2	Washer ... ..	...	...	...	...	...	...	...	...	4	4
29	F4311	Bracket ... ..	...	...	...	...	...	...	...	...	2	2
30	F3207	Spacer ... ..	...	...	...	...	...	...	...	...	2	2
31	H622	Bolt ( $1\frac{1}{2}$ in. U.H.) ... ..	...	...	...	...	...	...	...	...	2	2
32	E1330C	Plain washer ... ..	...	...	...	...	...	...	...	...	4	4
33	S1-52	Nut ... ..	...	...	...	...	...	...	...	...	4	4
35	F5041	Centre stand ... ..	...	...	...	...	...	...	...	...	1	1
36	F2610	Return spring ... ..	...	...	...	...	...	...	...	...	1	1
37	F3520	Pivot bolt ... ..	...	...	...	...	...	...	...	...	2	2
38	H193	Nut ... ..	...	...	...	...	...	...	...	...	2	2
39	F1245	Bolt ( $1\frac{5}{8}$ in. U.H.) ... ..	...	...	...	...	...	...	...	...	2	2
40	F3191	Bolt ( $2\frac{1}{4}$ in. U.H.) ... ..	...	...	...	...	...	...	...	...	1	1
41	F3955	Self-locking nut ... ..	...	...	...	...	...	...	...	...	3	3

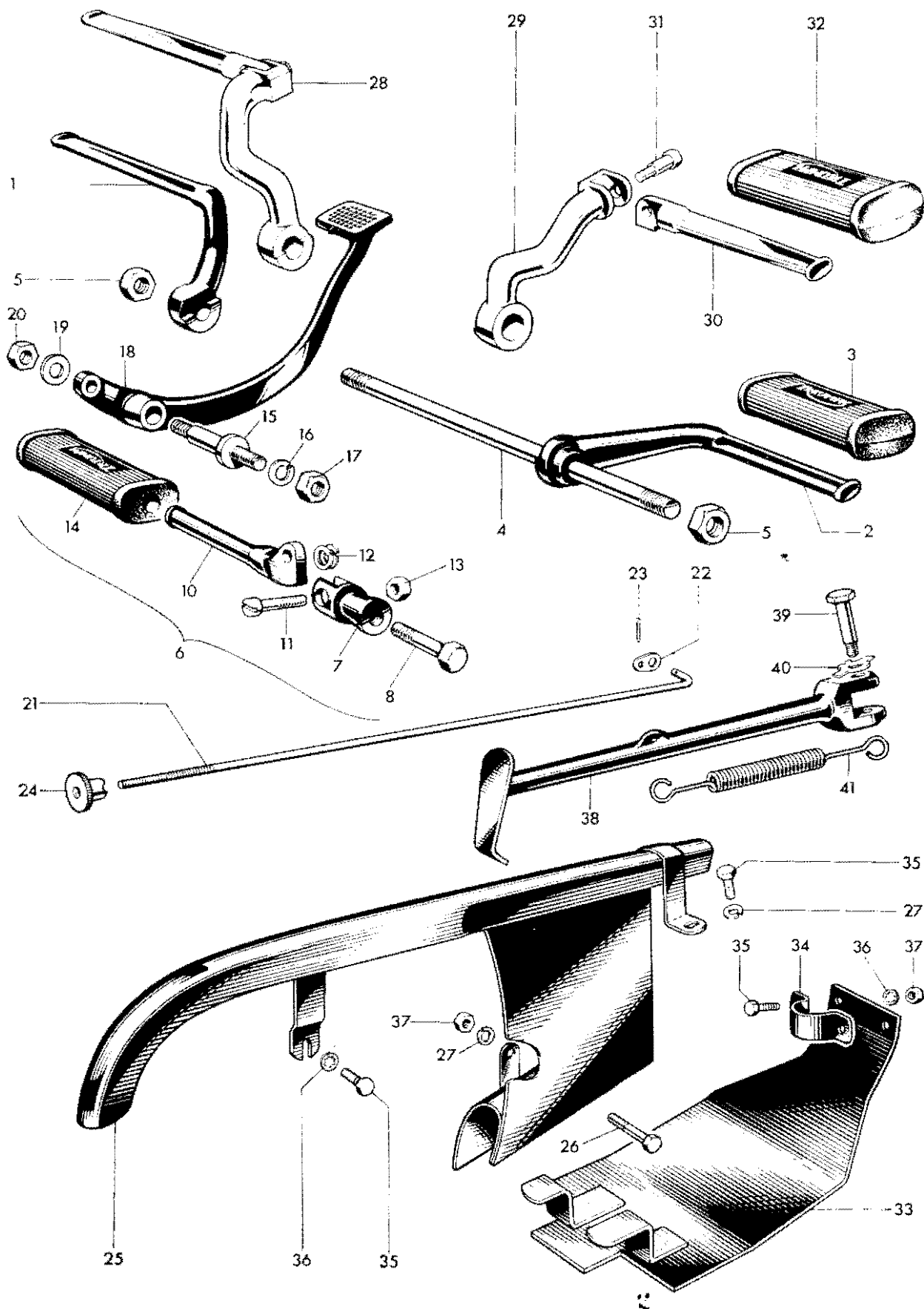

Fig. 8. FOOTRESTS, CHAINGUARD, PROPSTAND, ETC.

**FOOTRESTS, CHAINGUARD, PROPSTAND, ETC.**

			T20SM	T20SH
1	F4383	Left footrest ... ..	-	1
2	F3450	Right footrest ... ..	-	1
3	F1695	Pedal rubber ... ..	-	2
4	F3448	Footrest hanger rod (6 $\frac{3}{4}$ in. O.A.)	1	1
5	H193	Nut ... ..	2	2
6	F5552	PILLION FOOTREST	2	2
7	F2268	Footrest hanger	2	2
8	F5535	Bolt ( $\frac{1}{2}$ in. U.H.)	2	2
9	S26-1	Spring washer ... ..	2	2
10	F1694	Pedal ... ..	2	2
11	F2271	Pivot bolt ... ..	2	2
12	F2277	Spring washer ... ..	2	2
13	S1-51	Nut ... ..	2	2
14	F1695	Pedal rubber ... ..	2	2
15	F4090	Brake pedal spindle ... ..	1	1
16	S26-1	Spring washer ... ..	1	1
17	P0172A	Nut ... ..	1	1
18	F4091	Brake pedal ... ..	1	1
19	S25-3	Plain washer ... ..	1	1
20	T224	Nut ... ..	1	1
21	F4093	Brake rod ... ..	1	1
22	F3461	Washer ... ..	1	1
23	$\frac{1}{8}$ in. x $\frac{3}{8}$ in.	Split pin ... ..	1	1
24	F3463	Adjuster nut ... ..	1	1
25	F5053	Rear chainguard ... ..	1	1
26	F1369	Bolt ( $\frac{3}{8}$ in. U.H.) ... ..	1	1
27	S26-2	Spring washer ... ..	2	2
28	F6982	Left footrest hanger	1	-
29	F6983	Right footrest hanger	1	-
30	F6411	Pedal ... ..	2	-
31	F6655	Pivot bolt ... ..	2	-
32	F5022	Pedal rubber ... ..	2	-
33	F4258	Crankcase shield ... ..	1	-
34	F4260	Clip ... ..	1	-
35	DS57	Bolt ( $\frac{7}{16}$ in. U.H.) ... ..	5	3
36	E1612	Serrated washer ... ..	2	-
37	F879	Nut ... ..	3	1
38	F4277	PROP STAND COMPLETE	1	1
39	F3097	Pivot bolt ... ..	1	1
40	F3096	Tab washer ... ..	1	1
41	F2610	Return spring ... ..	1	1

FORK ASSEMBLY REF. N° 1

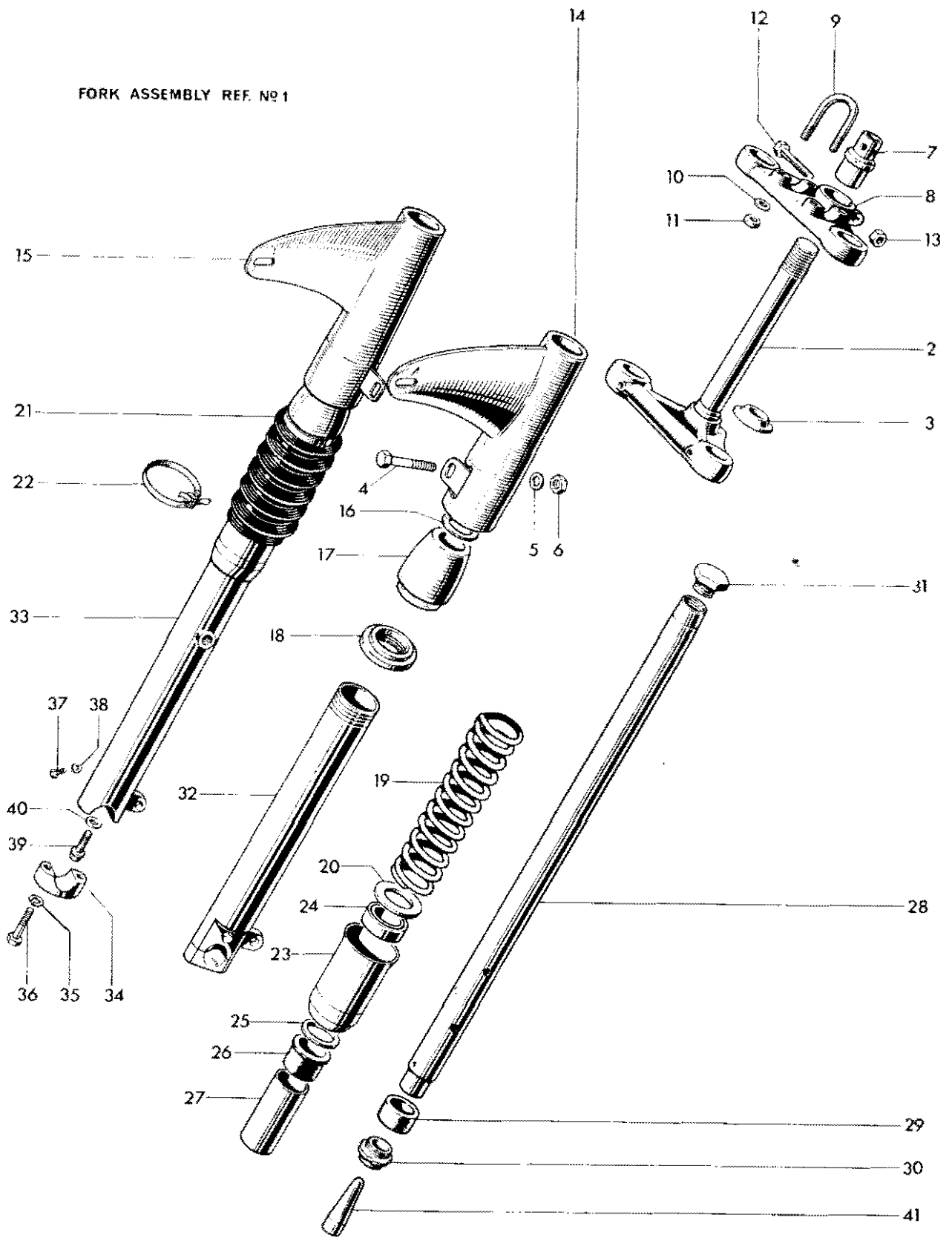

Fig. 9. TELESCOPIC FRONT FORK

Ref. No.	Part No.	DESCRIPTION	Quantity
<b>TELESCOPIC FRONT FORK</b>			
			T20SM T20SH
1	H1880	FORK ASSEMBLY ... ..	1 1
2	H1257	Middle lug and stem ... ..	1 1
3	H833	Bottom cone ... ..	1 1
4	H941	Pinch bolt (2¼ in. U.H.) ... ..	2 2
5	S25-2	Plain washer ... ..	2 2
6	H975	Nut ... ..	2 2
7	H1260	Fork stem sleeve nut ... ..	1 1
8	H1108	Top lug ... ..	1 1
9	H660	Handlebar 'U' bolt ... ..	2 2
10	S25-3	Plain washer ... ..	4 4
11	E1310	Nut ... ..	4 4
12	F1760	Pinch bolt (1⅞ in. U.H.) ... ..	1 1
13	H379	Seated nut ... ..	1 1
14	H1899	Left top cover ... ..	1 1
15	H1898	Right top cover... ..	1 1
16	F4047	Cork washer ... ..	2 2
17	H1867	Spring abutment ... ..	2 2
18	H1866	Spring cup ... ..	2 2
19	H1865	Main spring—Black/Yellow ... ..	2 2
20	H1656	Plain washer ... ..	2 2
21	H1645	Telescopic gaiter ... ..	2 2
22	H2083	Gaiter clip ... ..	4 4
23	H1654	DUST EXCLUDER SLEEVE NUT ... ..	2 2
24	H1500	Oil seal ... ..	2 2
25	H431	Plain washer ... ..	2 2
26	H441	Top bearing ... ..	2 2
27	H1896	Damping sleeve ... ..	2 2
28	H1928	STANCHION C/W BEARING ... ..	2 2
29	H443	Lower bearing ... ..	2 2
30	H1058	Bearing nut ... ..	2 2
31	H1658	Cap nut ... ..	2 2
32	H1842	LEFT BOTTOM MEMBER C/W CAP ... ..	1 1
33	H1843	RIGHT BOTTOM MEMBER C/W CAP ... ..	1 1
34	H1844	Spindle cap... ..	2 2
35	S26-3	Spring washer ... ..	4 4
36	H1070	Bolt (1⅞ in. U.H.) ... ..	4 4
37	H1071	Drain plug ... ..	2 2
38	H430	Fibre washer ... ..	2 2
39	H1063	Flanged bolt (⅜ in. U.H.) ... ..	2 2
40	H1062	Aluminium washer ... ..	2 2
41	H1499	Restrictor ... ..	2 2

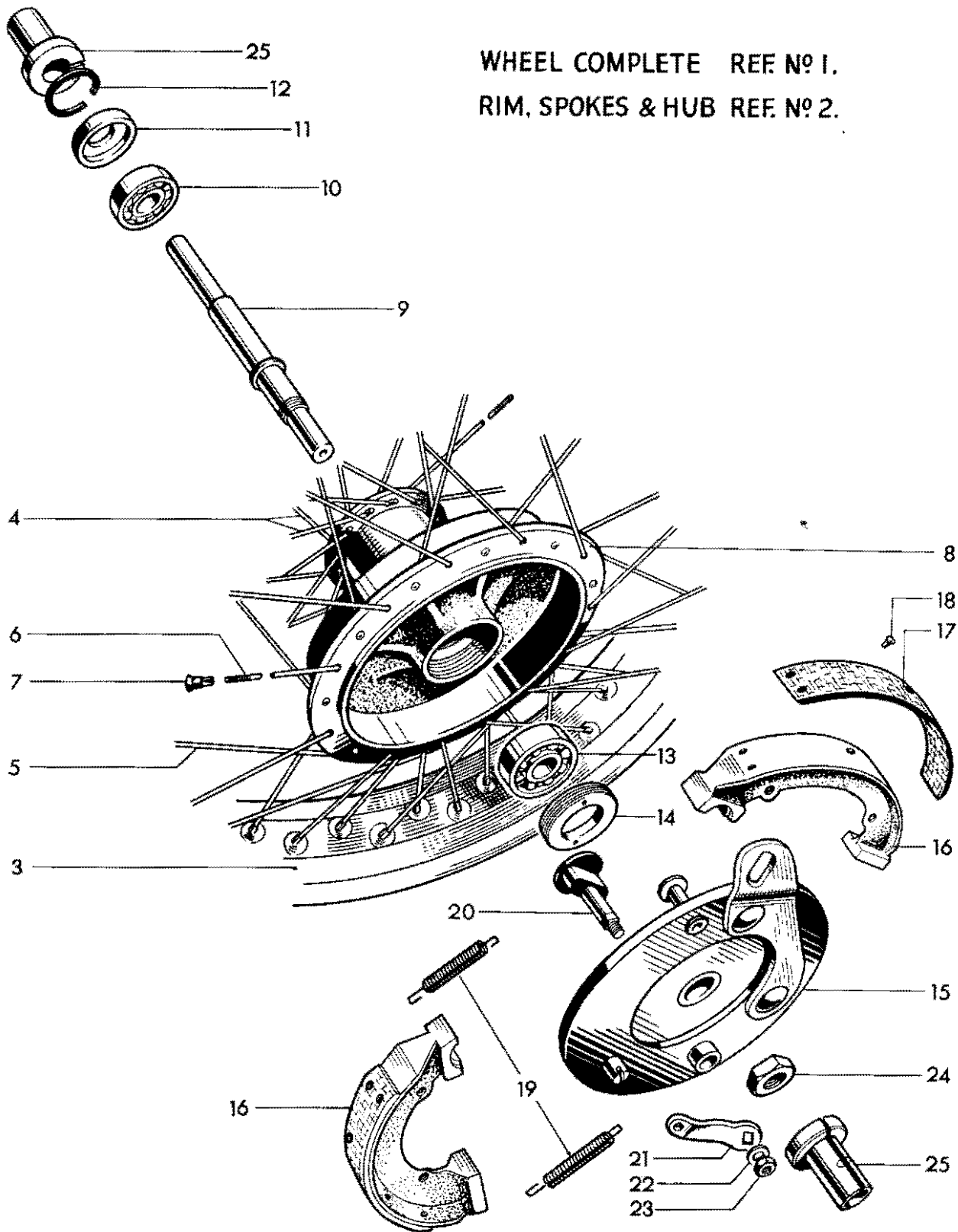
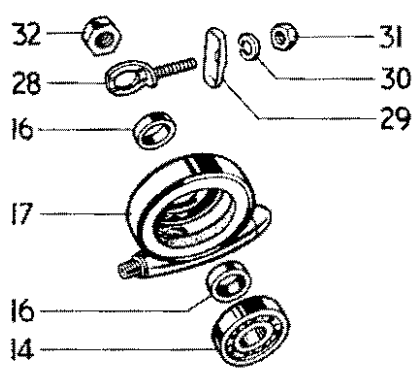

Fig. 10. FRONT WHEEL



## FRONT WHEEL

								T20SM	T20SH
1	W1655	FRONT WHEEL COMPLETE	...	...	...	...	...	1	1
2	W1285	RIM, SPOKES AND HUB ASSEMBLY	...	...	...	...	...	1	1
3	W1002	Front wheel rim, WM1-19	...	...	...	...	...	1	1
4	W1289	Spoke (10/12G x 8½ in. 90°) c/w nipple	...	...	...	...	...	20	20
5	W1205	Spoke (10/12G x 6¾ in. 100°) c/w nipple	...	...	...	...	...	10	10
6	W1206	Spoke (10/12G x 6¾ in. 80°) c/w nipple	...	...	...	...	...	10	10
7	W965	Nipple	...	...	...	...	...	40	40
8	W1286	Hub and brake drum	...	...	...	...	...	1	1
9	W1350	Wheel spindle	...	...	...	...	...	1	1
10	T530	Left bearing	...	...	...	...	...	1	1
11	W966	Dust cover	...	...	...	...	...	1	1
12	T532	Circlip	...	...	...	...	...	1	1
13	H826	Right bearing	...	...	...	...	...	1	1
14	W968	Retaining ring	...	...	...	...	...	1	1
15	W1650	Brake anchor plate	...	...	...	...	...	1	1
16	W977	BRAKE SHOE C/W LINING	...	...	...	...	...	2	2
17	W978	Brake lining	...	...	...	...	...	2	2
18	W979	Brass rivet	...	...	...	...	...	12	12
19	W200	Shoe return spring	...	...	...	...	...	1	1
20	W1128	Brake cam	...	...	...	...	...	1	1
21	W1653	Brake cam lever	...	...	...	...	...	1	1
22	S25-71	Plain washer	...	...	...	...	...	1	1
23	T224	Nut	...	...	...	...	...	1	1
24	W1093	Anchor plate nut	...	...	...	...	...	1	1
25	W1649	Spindle sleeve	...	...	...	...	...	2	2



WHEEL COMPLETE REF. N° 1  
RIM, SPOKES & HUB REF. N° 2

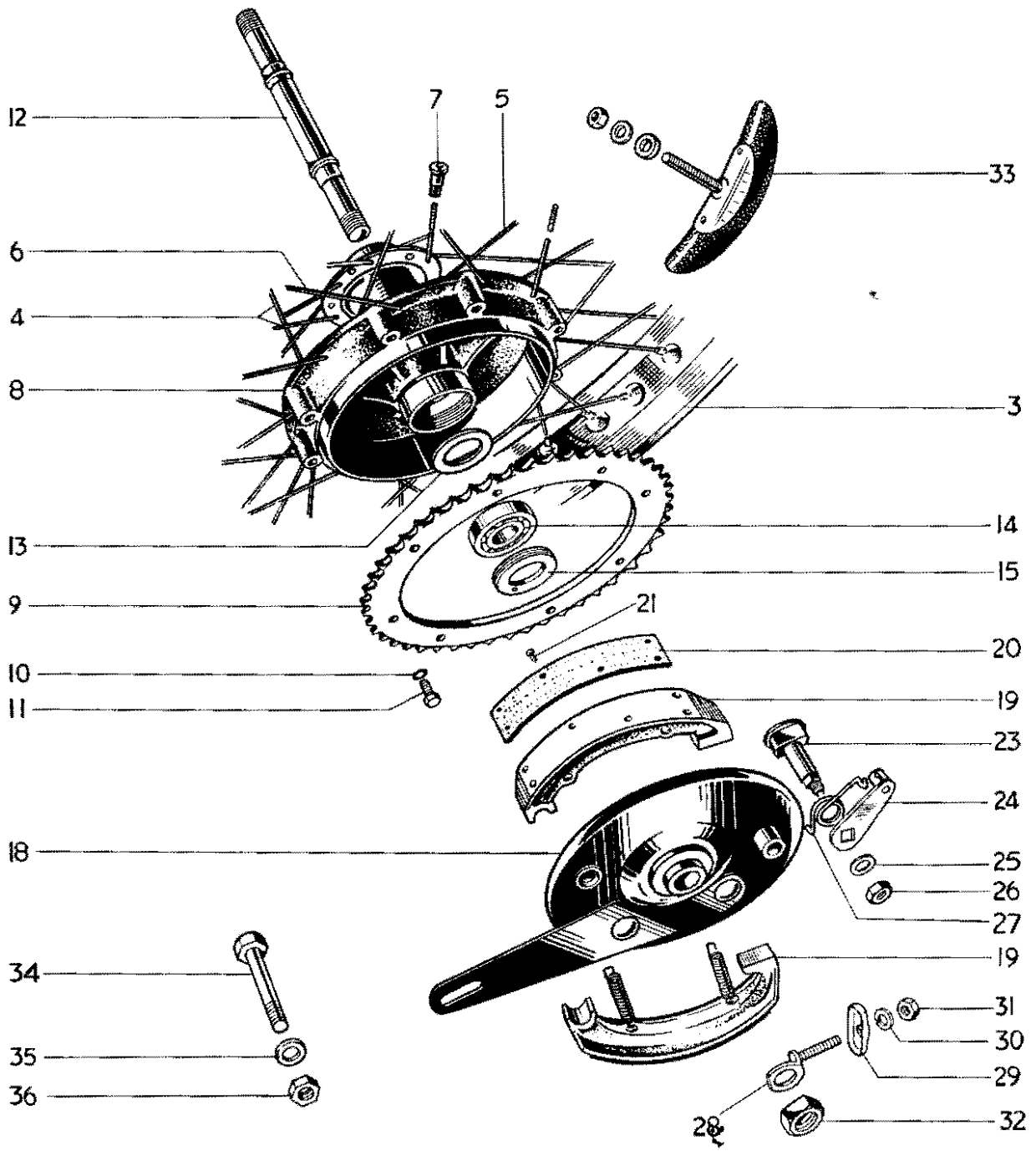

Fig. 11. REAR WHEEL

Ref. No.	Part No.	DESCRIPTION	QUANTITY	
			T20SM	T20SH
		<b>REAR WHEEL</b>		
1	W1418	REAR WHEEL COMPLETE	-	1
1	W1446	REAR WHEEL COMPLETE	1	-
2	W1368	RIM, SPOKES AND HUB ASSEMBLY	-	1
2	W1447	RIM, SPOKES AND HUB ASSEMBLY	1	-
3	W1296	Rear wheel rim WM 2-18	-	1
3	W1007	Rear wheel rim WM 3-18	1	-
4	W1293	Spoke (10/12G x 7 $\frac{1}{8}$ in. 90°) c/w nipple	-	20
4	W1465	Spoke (10G x 7 $\frac{1}{8}$ in. 90°) c/w nipple	20	-
5	W1294	Spoke (10/12G x 6 $\frac{3}{8}$ in. 100°) c/w nipple	-	10
5	W934	Spoke (10G x 6 $\frac{3}{8}$ in. 94°) c/w nipple	10	-
6	W1295	Spoke (10/12G x 6 $\frac{3}{8}$ in. 80°) c/w nipple	-	10
6	W933	Spoke (10G x 6 $\frac{3}{8}$ in. 83°) c/w nipple	10	-
7	W965	Nipple...	-	40
7	S79-2	Nipple...	40	-
8	W1362	Hub and brake drum	1	1
9	W1076	*Sprocket (54T)	1	-
9	W984	*5procket (48T)	-	1
10	W1122	Spring washer	8	8
11	W1322	Bolt ( $\frac{5}{8}$ in. U.H.)	8	8
12	W989	Spindle	1	1
13	W987	Backing ring	1	1
14	H826	Bearing	2	2
15	W988	Retaining ring	1	1
16	W1223	Distance piece	2	2
17	D175	Speedometer gearbox	1	1
18	W1365	Brake anchor plate	1	1
19	W977	BRAKE SHOE C/W LINING	2	2
20	W978	Brake lining	2	2
21	W979	Brass rivet	12	12
22	W200	Shoe return spring	2	2
23	W1128	Brake cam	1	1
24	W1221	Brake cam lever	1	1
25	S25-71	Plain washer	1	1
26	T224	Nut	1	1
27	W592	Return spring	1	-
28	W1224	Chain adjuster	2	2
29	W1227	End plate	2	2
30	S26-2	Spring washer	2	2
31	F879	Nut	2	2
32	W1000	Nut	2	2
33	D106	Tyre security bolt	-	1
33	WM-3	Tyre security bolt	2	-
34	H211	Bolt ( $\frac{5}{8}$ in. U.H.)	1	1
35	F2184	Plain washer	1	1
36	F3955	Self-locking nut	1	1

\*For alternative sprockets see Page 10.

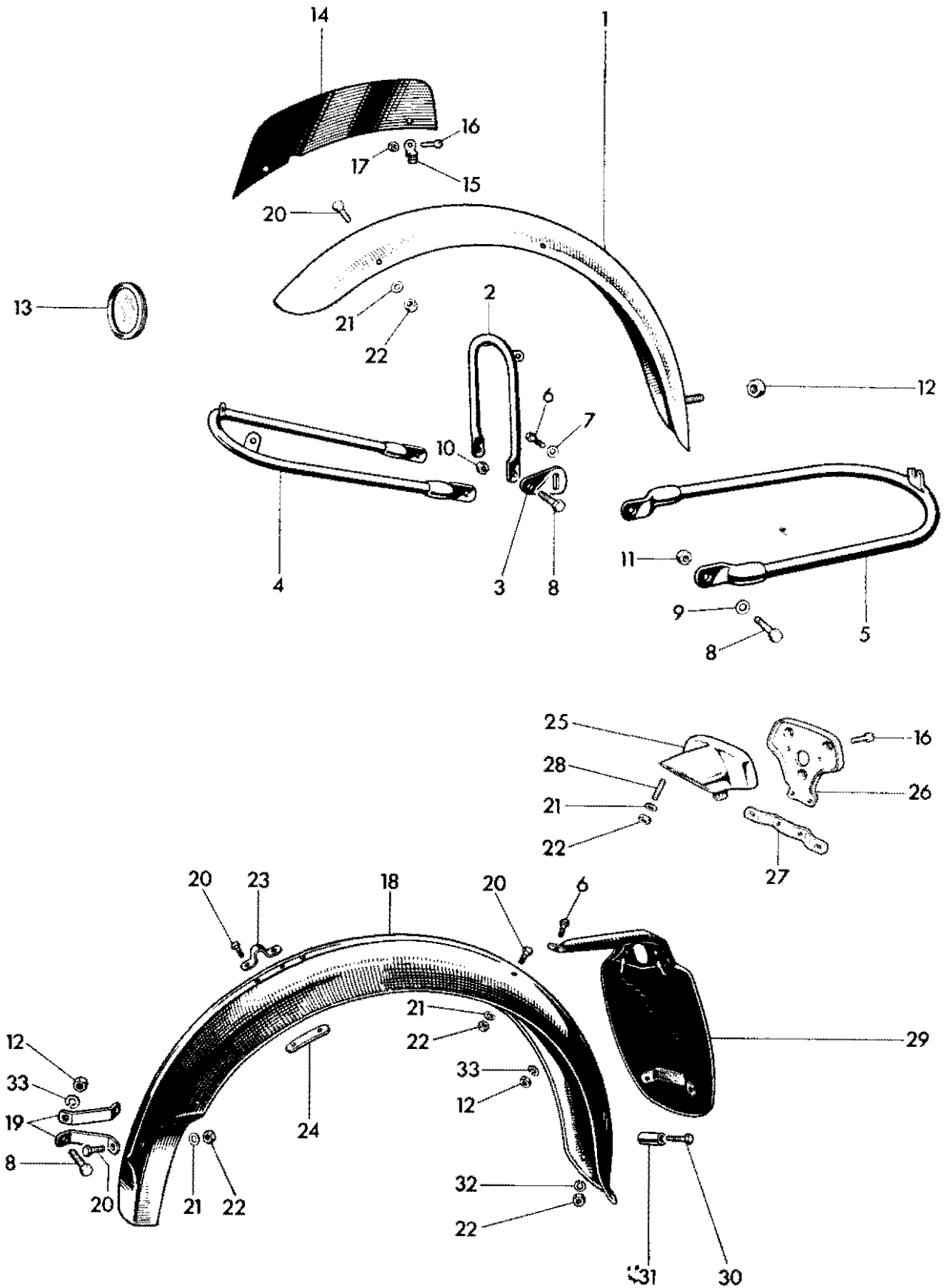

Fig. 12. MUDGUARDS AND NUMBER PLATES

## MUDGUARDS AND NUMBER PLATES

												T20SM	T20SH
1	H1677	Mudguard blade	...	...	...	...	...	...	...	...	...	1	-
1	H1675	Mudguard blade	...	...	...	...	...	...	...	...	...	-	1
2	H1683	Bridge	...	...	...	...	...	...	...	...	...	1	1
3	H1685	Bracket	...	...	...	...	...	...	...	...	...	2	2
4	H1681	Front stay	...	...	...	...	...	...	...	...	...	1	1
5	H1678	Lower stay	...	...	...	...	...	...	...	...	...	1	1
6	F929	Bolt ( $\frac{1}{2}$ in. U.H.)	...	...	...	...	...	...	...	...	...	2	3
7	F4299	Plain washer	...	...	...	...	...	...	...	...	...	2	2
8	DS55	Bolt ( $\frac{13}{16}$ in. U.H.)	...	...	...	...	...	...	...	...	...	5	5
9	S25-3	Plain washer	...	...	...	...	...	...	...	...	...	2	2
10	T224	Nut	...	...	...	...	...	...	...	...	...	2	2
11	W1691	Self-locking nut	...	...	...	...	...	...	...	...	...	2	2
12	S1-51	Nut	...	...	...	...	...	...	...	...	...	3	4
13	D261	Licence holder	...	...	...	...	...	...	...	...	...	-	1
14	F6470	Number plate	...	...	...	...	...	...	...	...	...	-	1
15	H741	Clip assembly	...	...	...	...	...	...	...	...	...	-	2
16	F4715	Screw ( $\frac{13}{32}$ in. U.H.)	...	...	...	...	...	...	...	...	...	3	2
17	H745	Nut	...	...	...	...	...	...	...	...	...	-	2
18	F6986	Mudguard	...	...	...	...	...	...	...	...	...	1	-
18	F6524	Mudguard	...	...	...	...	...	...	...	...	...	-	1
19	F5640	Stay	...	...	...	...	...	...	...	...	...	2	2
20	DS57	Bolt ( $\frac{7}{16}$ in. U.H.)	...	...	...	...	...	...	...	...	...	12	8
21	S25-1	Plain washer	...	...	...	...	...	...	...	...	...	17	12
22	F879	Nut	...	...	...	...	...	...	...	...	...	19	14
23	PF204	Clip	...	...	...	...	...	...	...	...	...	1	1
24	F444	Backing plate	...	...	...	...	...	...	...	...	...	1	1
25	F6928	Tail lamp adaptor	...	...	...	...	...	...	...	...	...	1	-
26	F6945	Tail lamp plate	...	...	...	...	...	...	...	...	...	1	-
27	F6984	Registration plate bracket	...	...	...	...	...	...	...	...	...	2	-
28	E2980	Stud ( $\frac{1}{2}$ in. O.H.)	...	...	...	...	...	...	...	...	...	1	-
29	F5924	Number plate	...	...	...	...	...	...	...	...	...	-	1
30	F1149	Bolt ( $\frac{7}{8}$ in. U.H.)	...	...	...	...	...	...	...	...	...	-	2
31	F5410	Distance piece	...	...	...	...	...	...	...	...	...	-	2
32	S26-2	Spring washer	...	...	...	...	...	...	...	...	...	-	2
33	S26-3	Spring washer	...	...	...	...	...	...	...	...	...	1	2

TWINSEAT ASSY. REF. No.1

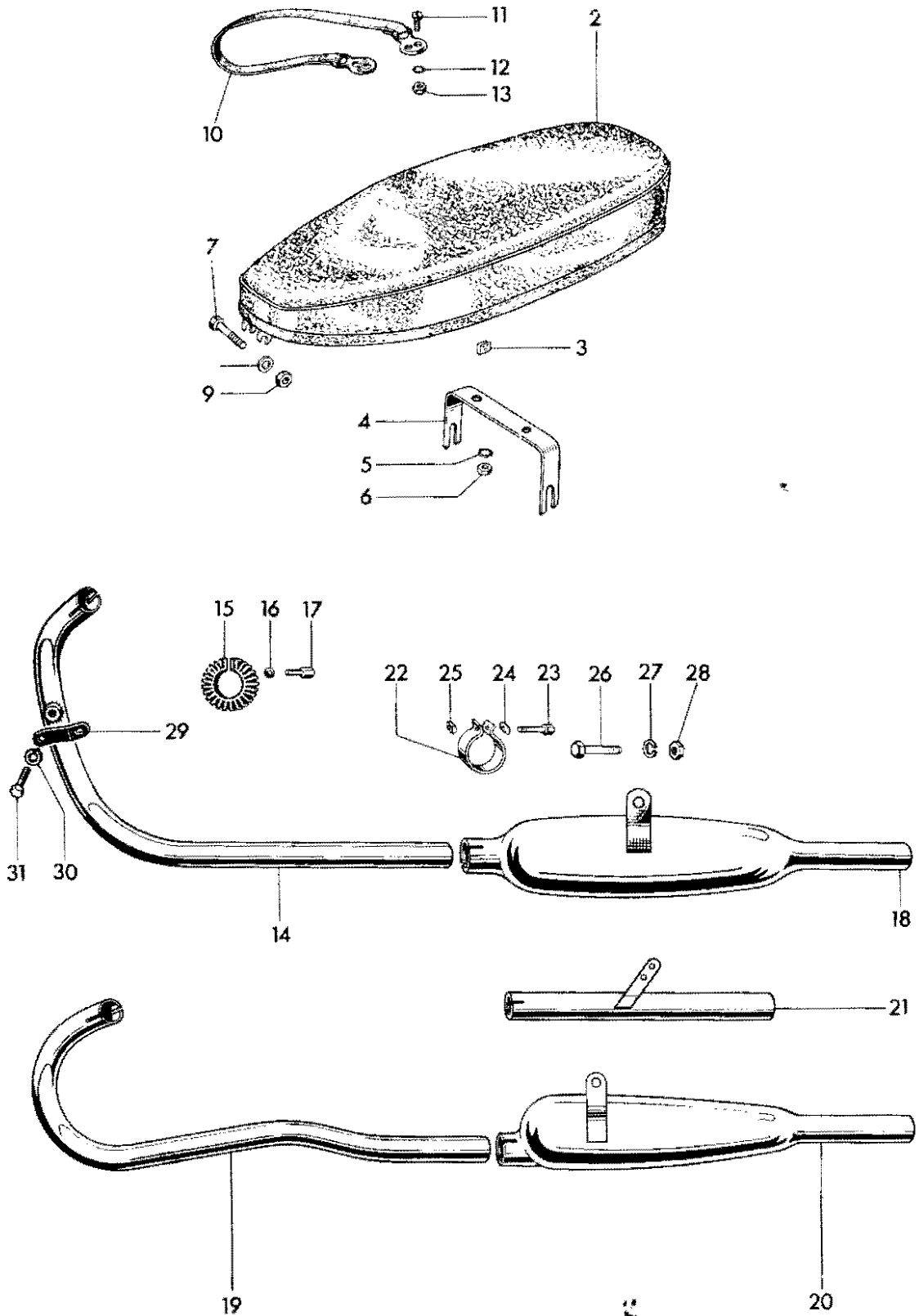

Fig. 13. TWINSEAT, REAR PANELS AND EXHAUST SYSTEM

## TWINSEAT, REAR PANELS AND EXHAUST SYSTEM

											T20SM	T20SH
1	F4272	TWINSEAT COMPLETE	...	...	...	...	...	...	...	...	1	1
2	F4104	Cover c/w clips	...	...	...	...	...	...	...	...	1	1
3	F4475	Clip	...	...	...	...	...	...	...	...	as required	
4	F4261	Rear bracket	...	...	...	...	...	...	...	...	1	1
5	E1612	Serrated washer	...	...	...	...	...	...	...	...	2	2
6	F879	Nut	...	...	...	...	...	...	...	...	2	2
7	E667A	Bolt (1½ in. U.H.)	...	...	...	...	...	...	...	...	1	1
8	S25-3	Plain washer	...	...	...	...	...	...	...	...	1	1
9	E1310	Nut	...	...	...	...	...	...	...	...	1	1
10	F4361	Safety strap	...	...	...	...	...	...	...	...	1	A
11	F4129	Screw (½ in. U.H.)	...	...	...	...	...	...	...	...	4	4
12	GS299	Serrated washer	...	...	...	...	...	...	...	...	4	4
13	H745	Nut	...	...	...	...	...	...	...	...	4	4
14	E4738	Exhaust pipe	...	...	...	...	...	...	...	...	-	1
15	E4932	Clip (chrome)	...	...	...	...	...	...	...	...	1	1
16	S25-13	Plain washer	...	...	...	...	...	...	...	...	1	1
17	E3260	Bolt (⅞ in. U.H.)	...	...	...	...	...	...	...	...	1	1
18	E3928	Silencer	...	...	...	...	...	...	...	...	1	1
19	E4497	Exhaust pipe (upswept)	...	...	...	...	...	...	...	...	1	-
20	E4496	Silencer (upswept)	...	...	...	...	...	...	...	...	1	-
21	E3967	Extension pipe	...	...	...	...	...	...	...	...	-	A
22	E3269	Clip	...	...	...	...	...	...	...	...	1	1
23	TE164E	Bolt	...	...	...	...	...	...	...	...	1	1
24	TE164D	"D" washer	...	...	...	...	...	...	...	...	1	1
25	TE164C	"D" nut	...	...	...	...	...	...	...	...	1	1
26	F1031	Bolt (½ in. U.H.), silencer hanger	...	...	...	...	...	...	...	...	A	A
27	S26-1	Spring washer	...	...	...	...	...	...	...	...	A	A
28	P0172A	Nut	...	...	...	...	...	...	...	...	A	A
29	E4737	Bracket	...	...	...	...	...	...	...	...	1	1
30	S26-3	Spring washer	...	...	...	...	...	...	...	...	1	1
31	F929	Bolt	...	...	...	...	...	...	...	...	1	1

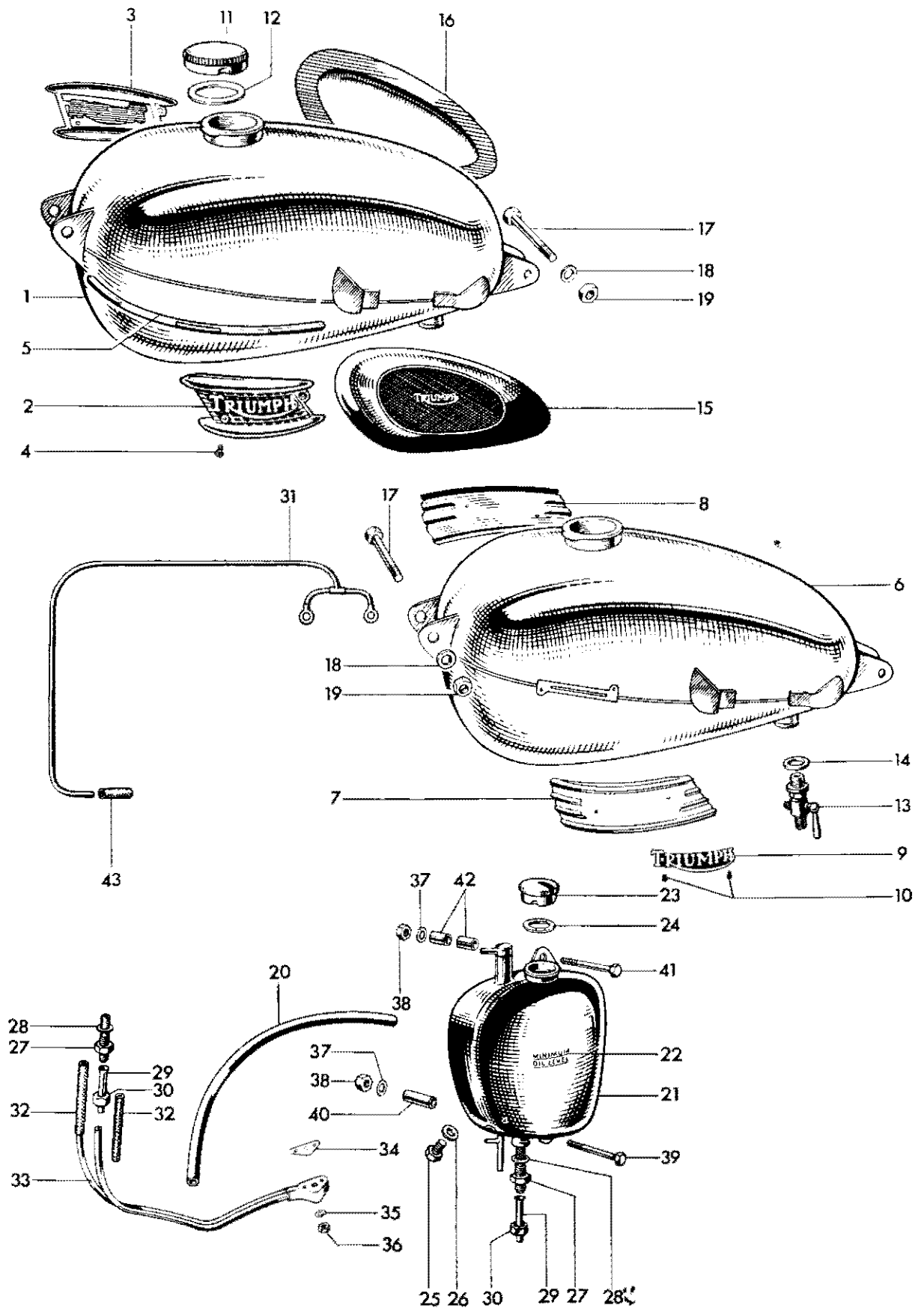

Fig. 14. PETROL AND OIL TANKS



Ref. No.	Part No.	DESCRIPTION	QUANTITY	
			T20SM	T20SH
<b>PETROL AND OIL TANKS</b>				
1	F4496	Petrol tank (3 gallons)	-	1
2	F4570	Left styling unit	-	1
3	F4571	Right styling unit	-	1
4	F4468	Screw ( $\frac{9}{16}$ in. U.H.)	-	4
5	F5100	Styling strip	-	2
6	F3505	Petrol tank ( $2\frac{1}{2}$ gallons)	1	-
7	F3494	Left styling band	1	-
8	F3495	Right styling band	1	-
9	F3496	Nameplate	2	-
10	F3497	Screw ( $\frac{1}{2}$ in. U.H.)	4	-
11	F3220	FILLER CAP	1	1
12	F4048	Joint washer	1	1
13	F4908	Petrol tap	1	1
14	E697	Fibre washer	1	1
15	F1606	Left knee grip	1	1
16	F1605	Right knee grip	1	1
17	F3498	Bolt ( $2\frac{3}{8}$ in. U.H.)	2	2
18	S25-3	Plain washer	2	2
19	S1-51	Nut	2	2
20	T1203	Flexible vent pipe	1	1
21	F4572	OIL TANK	1	1
22	A3	Transfer (Minimum oil level)	1	1
23	F3216	FILLER CAP	1	1
24	F4047	Joint washer	1	1
25	F5343	Drain plug	1	1
26	PT104B	Fibre washer	1	1
27	F3876	Filter	1	1
28	F1511	Fibre washer	1	1
29	F3503	Upper feed pipe	1	1
30	F3504	Union nut	1	1
31	E3244	Rocker oil feed pipe...	1	1
32	E6116	Rubber connector	2	2
33	E6113	Oil pipes and junction block	1	1
34	E3274	Joint washer	1	1
35	S25-13	Plain washer	1	1
36	F879	Nut	1	1
37	S25-3	Plain washer	2	2
38	S1-51	Nut	2	2
39	F2596	Bolt ( $1\frac{7}{8}$ in. U.H.)	1	1
40	F3477	Distance piece	1	1
41	F3468	Bolt ( $2\frac{1}{16}$ in. U.H.)	1	1
42	F3476	Distance piece	2	2
43	E3383	Rubber connector	1	1

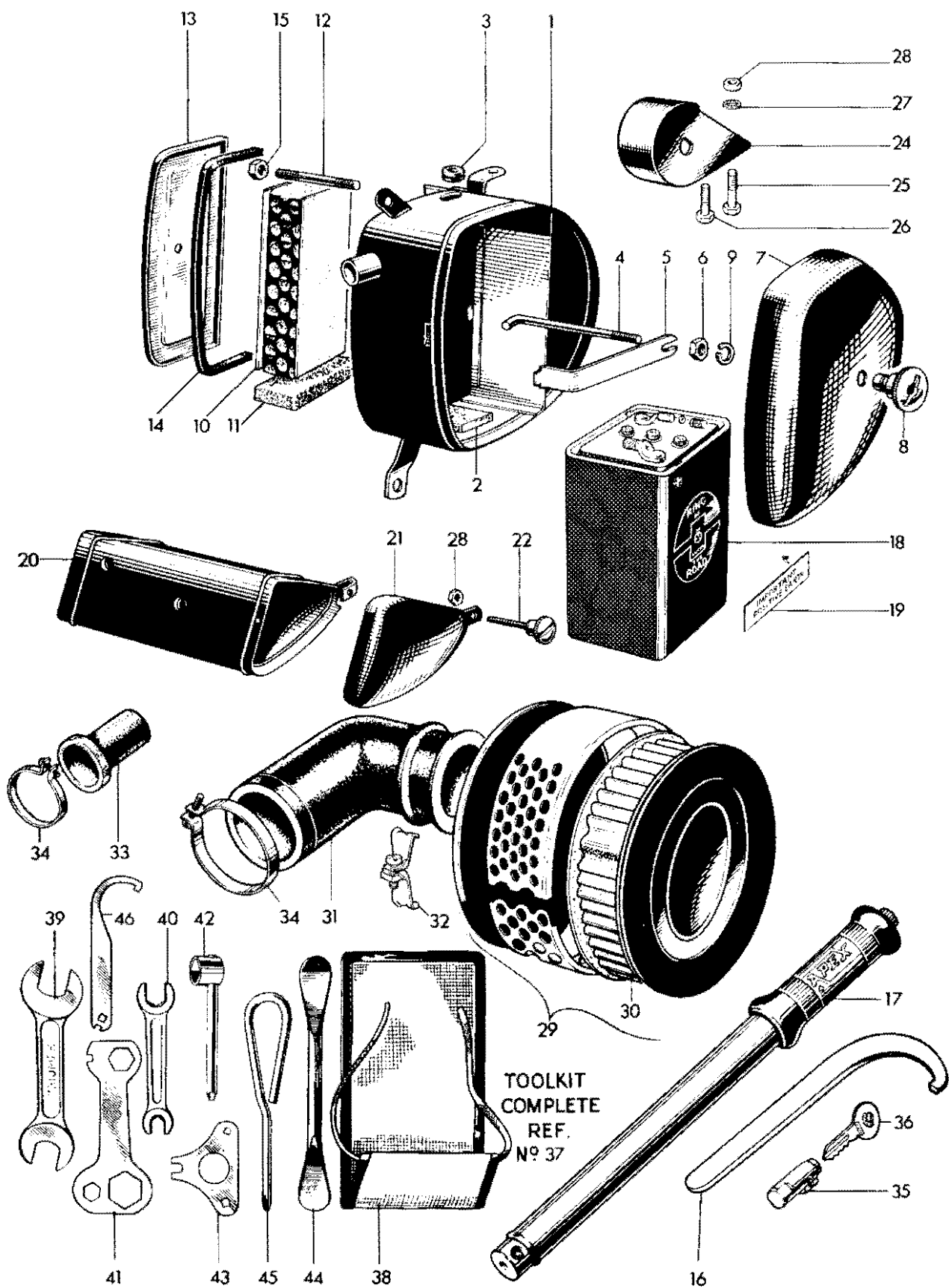
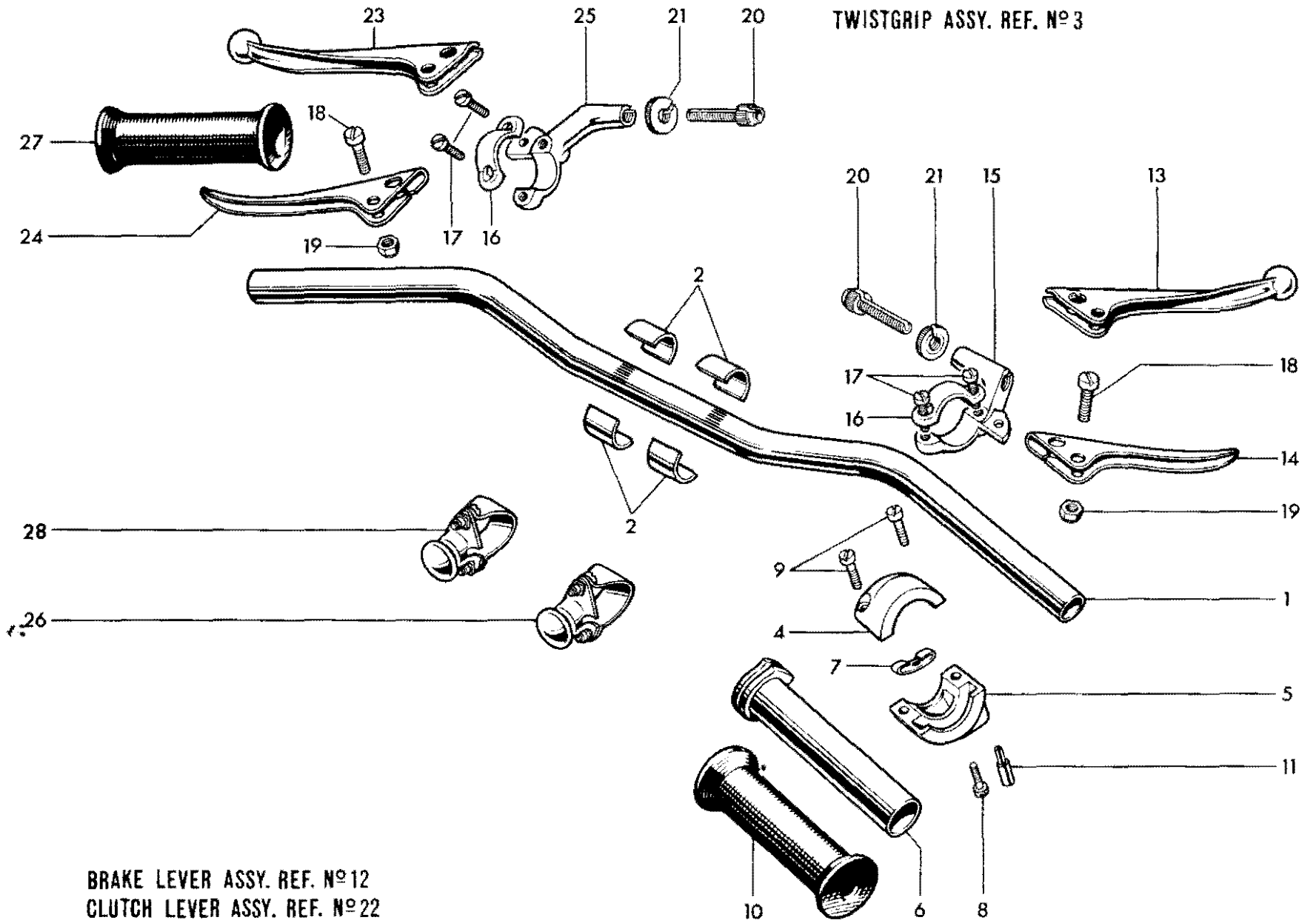

Fig. 15. BATTERY CASE, TOOLBOX AND AIR FILTER

## BATTERY CASE, TOOLBOX AND AIR FILTER

			T20SM	T20SH
1	F5139	BATTERY CASE, AIR FILTER AND TOOL BOX ... ..	-	1
2	F3470	Rubber pad ... ..	-	2
3	199002	Grommet ... ..	-	1
4	F3472	Hook bolt ... ..	-	1
5	F3473	Strap ... ..	-	1
6	F879	Nut ... ..	-	1
7	F3493	Lid c/w knob ... ..	-	1
8	F3474	Knob ... ..	-	1
9	F3475	Circlip ... ..	-	1
10	F5137	Air filter element ... ..	-	1
11	F5140	Rubber pad ... ..	-	1
12	F3656	Stud (1½ in. O.A.) ... ..	-	1
13	F5141	Lid ... ..	-	1
14	H251	Beading ... ..	-	1
15	H745	Nut ... ..	-	1
16	D527	Fork sleeve nut spanner ... ..	as required	
17	D296	Tyre inflator ... ..	-	1
18	408200	Battery PUZ5E/11 ... ..	-	1
19	A52	Transfer "Positive earth" ... ..	-	1
20	F4877	TOOLBOX ... ..	1	-
21	F4882	Toolbox lid ... ..	1	-
22	F4885	Fastener screw ... ..	1	-
23	F4717	Self locking nut ... ..	1	-
24	F5143	Switch bracket ... ..	-	2
25	F1369	Bolt (⅝ in. U.H.) ... ..	-	1
26	DS57	Bolt (⅞ in. U.H.) ... ..	-	3
27	E1612	Serrated washer ... ..	-	4
28	F879	Nut ... ..	-	4
29	F6428	AIR FILTER ... ..	1	-
30	F5694	Element and back plate assembly (paper element)... ..	1	-
31	F5038	Rubber connector ... ..	1	-
32	F4810	Clip ... ..	1	-
33	F5142	Rubber connector ... ..	-	1
34	F3859	Clip ... ..	1	1
35	D402/3	FRAME LOCK C/W 2 KEYS ... ..	1	1
36	D403	Key (state number) ... ..	1	1
37	D290	TOOLKIT ... ..	-	1
37	D533	TOOLKIT ... ..	1	-
38	D291	Toolbag ... ..	1	1
39	D299	Open spanner, ⅜ in. x ⅞ in. Whit. ... ..	1	1
40	D292	Open spanner, ⅛ in. x ⅜ in. x ¼ in. x ⅝ in. Whit. ... ..	1	1
41	D293	Combination spanner, ⅜ in. x ⅝ in. x ½ in. Whit. ... ..	1	1
42	D294	Screwdriver and ¼ in. Whit. spanner ... ..	1	1
43	DA70	Clutch key ... ..	1	1
44	NA14A	Tyre lever ... ..	1	1
45	D335	Phillips No. 2 screwdriver ... ..	1	1
46	D362	"C" spanner ... ..	1	-

Fig. 16. HANDLEBARS AND CONTROL LEVERS



## HANDLEBARS AND CONTROL LEVERS

			T20SM	T20SH
1	H1519	Handlebar bend ... ..	1	-
1	H527	Handlebar bend ... ..	-	1
2	H1425	Packing piece ... ..	4	4
3	366/2	TWISTGRIP ... ..	1	1
4	366/001	Body top half ... ..	1	1
5	366/002	Body bottom half ... ..	1	1
6	366/004	Rotor ... ..	1	1
7	366/007	Friction spring ... ..	1	1
8	366/008	Friction spring screw ... ..	1	1
9	376/079	Screw ... ..	2	2
10	16/070	Handlebar grip ... ..	1	1
11	366/006	Cable stop ... ..	1	1
12	18/1065	FRONT BRAKE LEVER ASSEMBLY (Ball end) ... ..	1	-
12	18/999	FRONT BRAKE LEVER ASSEMBLY ... ..	-	1
13	18/754	Brake lever (Ball end) ... ..	1	-
14	18/535	Brake lever ... ..	-	1
15	18/1013	Brake lever bracket ... ..	1	1
16	12/595	Clamp ... ..	1	1
17	11/014	Screw ... ..	2	2
18	18/087	Fulcrum screw ... ..	1	1
19	18/053	Self-locking nut ... ..	1	1
20	18/1005	Cable adjuster ... ..	1	1
21	18/1006	Thumb nut ... ..	1	1
22	18/1066	CLUTCH LEVER ASSEMBLY (Ball end) ... ..	1	-
22	18/1000	CLUTCH LEVER ASSEMBLY ... ..	-	1
23	18/752	Clutch lever (Ball end) ... ..	1	-
24	18/528	Clutch lever ... ..	-	1
25	18/1009	Clutch lever bracket ... ..	1	1
16	12/595	Clamp ... ..	1	1
17	11/014	Screw ... ..	2	2
18	18/087	Fulcrum screw ... ..	1	1
19	18/053	Self-locking nut ... ..	1	1
20	18/1005	Cable adjuster ... ..	1	-
21	18/1006	Thumb nut ... ..	1	-
26	76204	Horn push or cut-out button, type 4A ... ..	2	1
27	16/069	Handlebar grip ... ..	1	1
28	D553	Horn button, Clear Hooters No. 10 ... ..	1	-

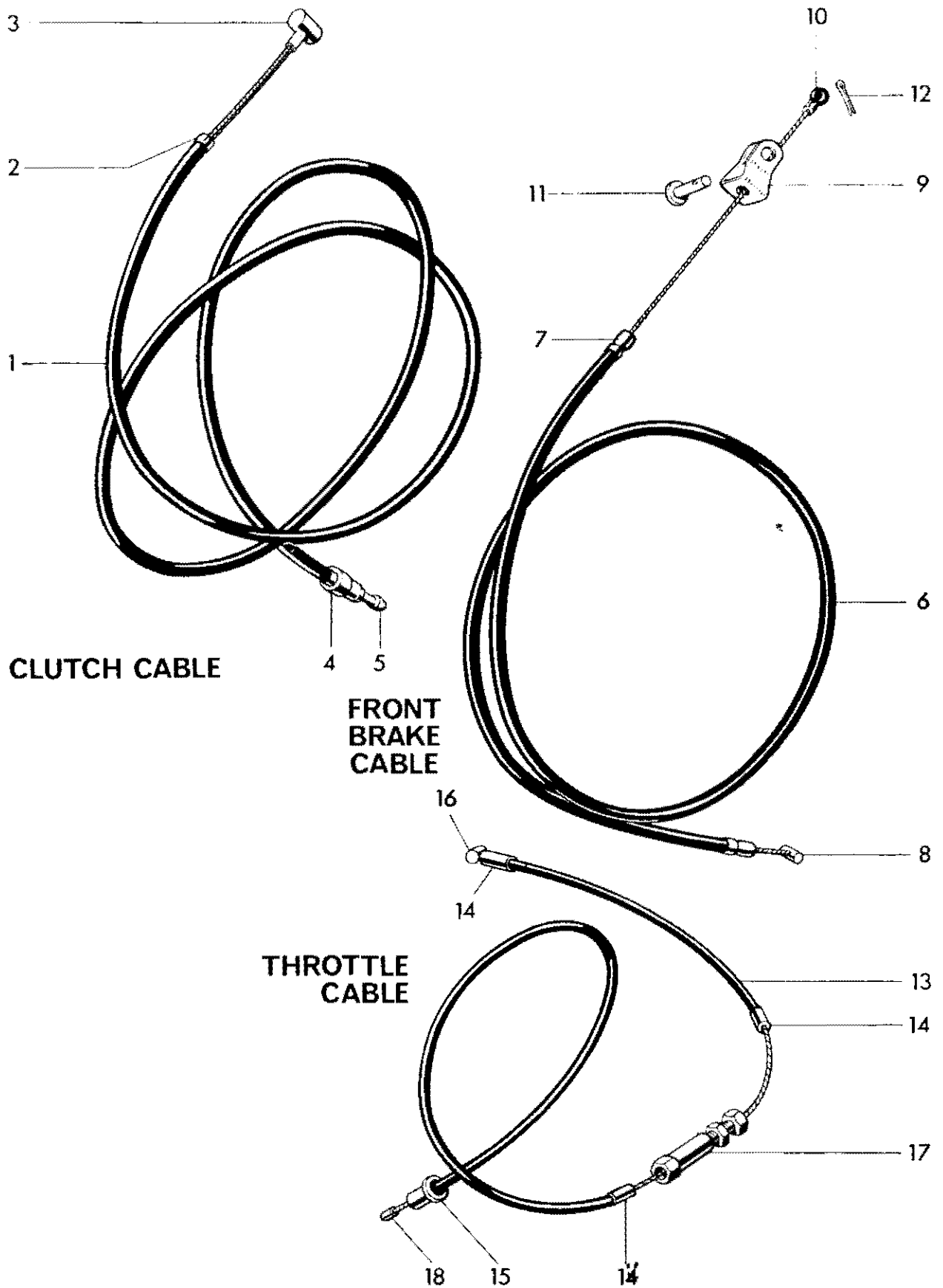

Fig. 17. CONTROL CABLES

**CONTROL CABLES**

											T20SM	T20SH
1	D567	CLUTCH CABLE	...	...	...	...	...	...	...	...	1	1
2	D103	Ferrule	...	...	...	...	...	...	...	...	2	2
3	D506	Nipple (H/Bar end)	...	...	...	...	...	...	...	...	1	1
4	D333	Abutment	...	...	...	...	...	...	...	...	1	1
5	D334	Nipple	...	...	...	...	...	...	...	...	1	1
6	D564	FRONT BRAKE CABLE	...	...	...	...	...	...	...	...	1	-
6	D569	FRONT BRAKE CABLE	...	...	...	...	...	...	...	...	-	1
7	D103	Ferrule	...	...	...	...	...	...	...	...	2	2
8	D506	Nipple (H/Bar end)	...	...	...	...	...	...	...	...	1	1
9	D280	Clevis	...	...	...	...	...	...	...	...	1	1
10	DS73	Nipple	...	...	...	...	...	...	...	...	1	1
11	D281	Clevis pin	...	...	...	...	...	...	...	...	1	1
12	$\frac{1}{8}$ in. x $\frac{3}{8}$ in.	Split pin	...	...	...	...	...	...	...	...	1	1
13	D420	THROTTLE CABLE	...	...	...	...	...	...	...	...	1	1
14	12/083	Ferrule	...	...	...	...	...	...	...	...	3	3
15	6/132A	Ferrule	...	...	...	...	...	...	...	...	1	1
16	D411	Nipple (H/Bar end)	...	...	...	...	...	...	...	...	1	1
17	D104	Adjuster	...	...	...	...	...	...	...	...	1	1
18	NS191	Nipple	...	...	...	...	...	...	...	...	1	1

# CARBURETTER COMPLETE REF. No. 1

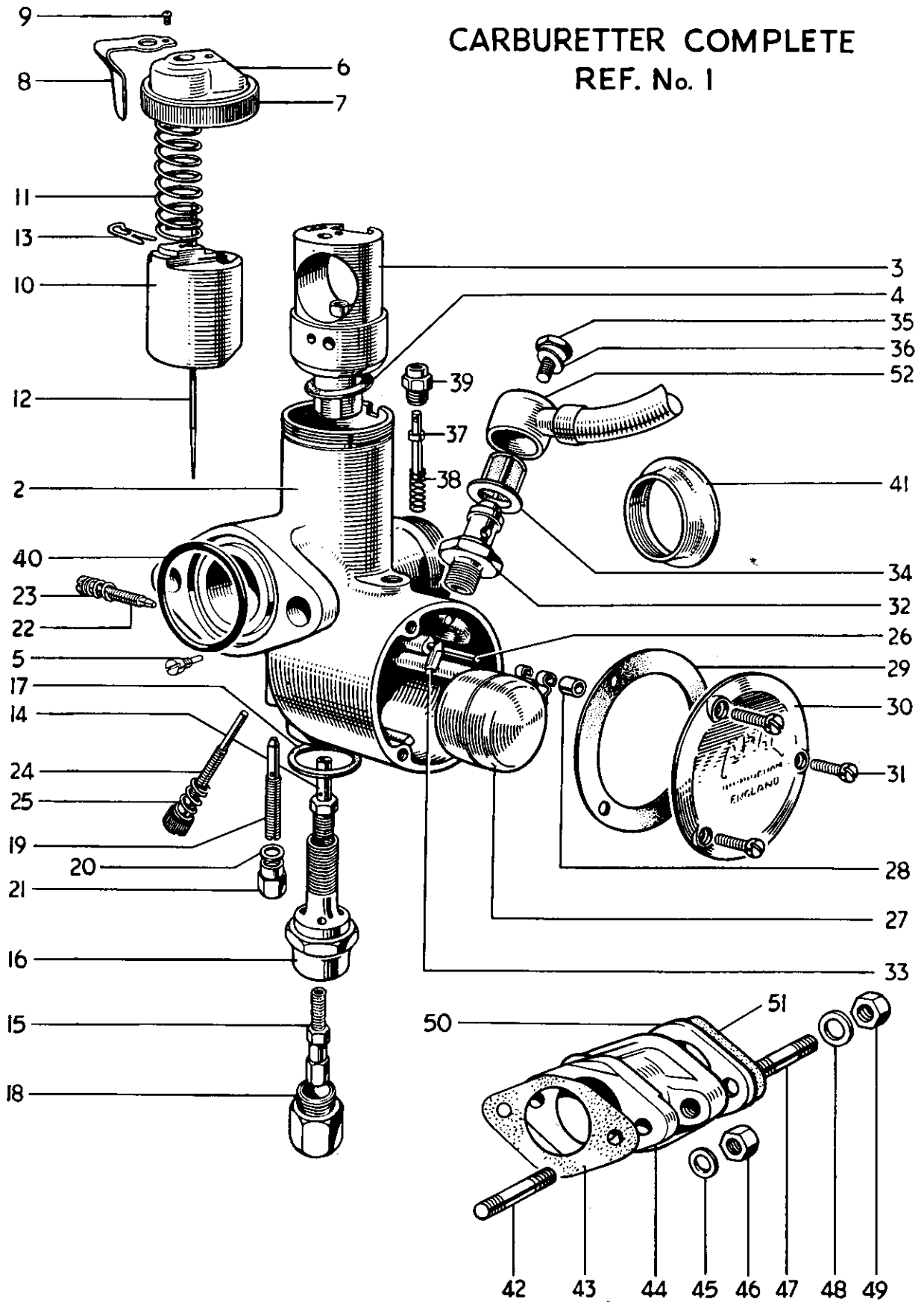

Fig. 18. AMAL CARBURETTER, TYPE 376



### AMAL CARBURETTER, TYPE 376

			T20SM	T20SH
1	376/272	CARBURETTER COMPLETE (T20SM 376/314) ...	1	1
2	376/001	Mixing chamber ...	1	1
3	376/055	Jet block... ...	1	1
4	376/067	Joint washer ...	1	1
5	376/070	Peg screw ...	1	1
6	376/155	Mixing chamber top ...	1	1
7	376/065	Cap ring ...	1	1
8	29/308	Spring ...	1	1
9	4/241	Screw ...	1	1
10	376/060	Throttle valve (No. 3 Cutaway) (T20SM—2½ Cutaway) ...	1	1
11	376/061	Spring ...	1	1
12	376/063	Needle (Type C) ...	1	1
13	4/230	Clip ...	1	1
14	376/072	Needle jet (106) (T20SM—105) ...	1	1
15	376/100	Main jet (140) ...	1	1
16	376/073	Jet holder ...	1	1
17	376/074	Fibre washer ...	1	1
18	376/075	Cover nut ...	1	1
19	376/076	Pilot jet (20) (T20SM—15) ...	1	1
20	116/162	Fibre washer ...	1	1
21	376/095	Cover nut ...	1	1
22	332/017	Air adjusting screw ...	1	1
23	4/148	Spring ...	1	1
24	376/068	Throttle stop screw ...	1	1
25	376/069	Spring ...	1	1
26	376/085	Float spindle ...	1	1
27	376/083	Float ...	1	1
28	376/094	Bush ...	1	1
29	376/078	Joint washer ...	1	1
30	376/077	Cover ...	1	1
31	376/079	Screw ...	3	3
32	376/088	Needle seating ...	1	1
33	376/089	Needle ...	1	1
34	376/093	Filter ...	1	1
35	376/091	Boit ...	1	1
36	376/092	Fibre washer ...	1	1
37	376/086	Tickler ...	1	1
38	376/087	Spring ...	1	1
39	343/011	Tickler body ...	1	1
40	244/1048	"O" ring seal ...	1	1
41	376/066	Air intake tube ...	A	A
42	E6549	Stud (1 in. O.A.) ...	2	2
43	E5902	Joint washer ...	1	1
44	E5900	Adaptor ...	1	1
45	E2728	Plain washer ...	2	2
46	E5269	Nut ...	2	2
47	E6550	Stud (1½ in. O.A.) ...	2	2
48	S25-3	Plain washer ...	2	2
49	S1-51	Nut ...	2	2
50	E4504	Insulating block ...	1	1
51	NA43	Joint washer ...	1	1
52	F4886	Petrol pipe ...	1	1

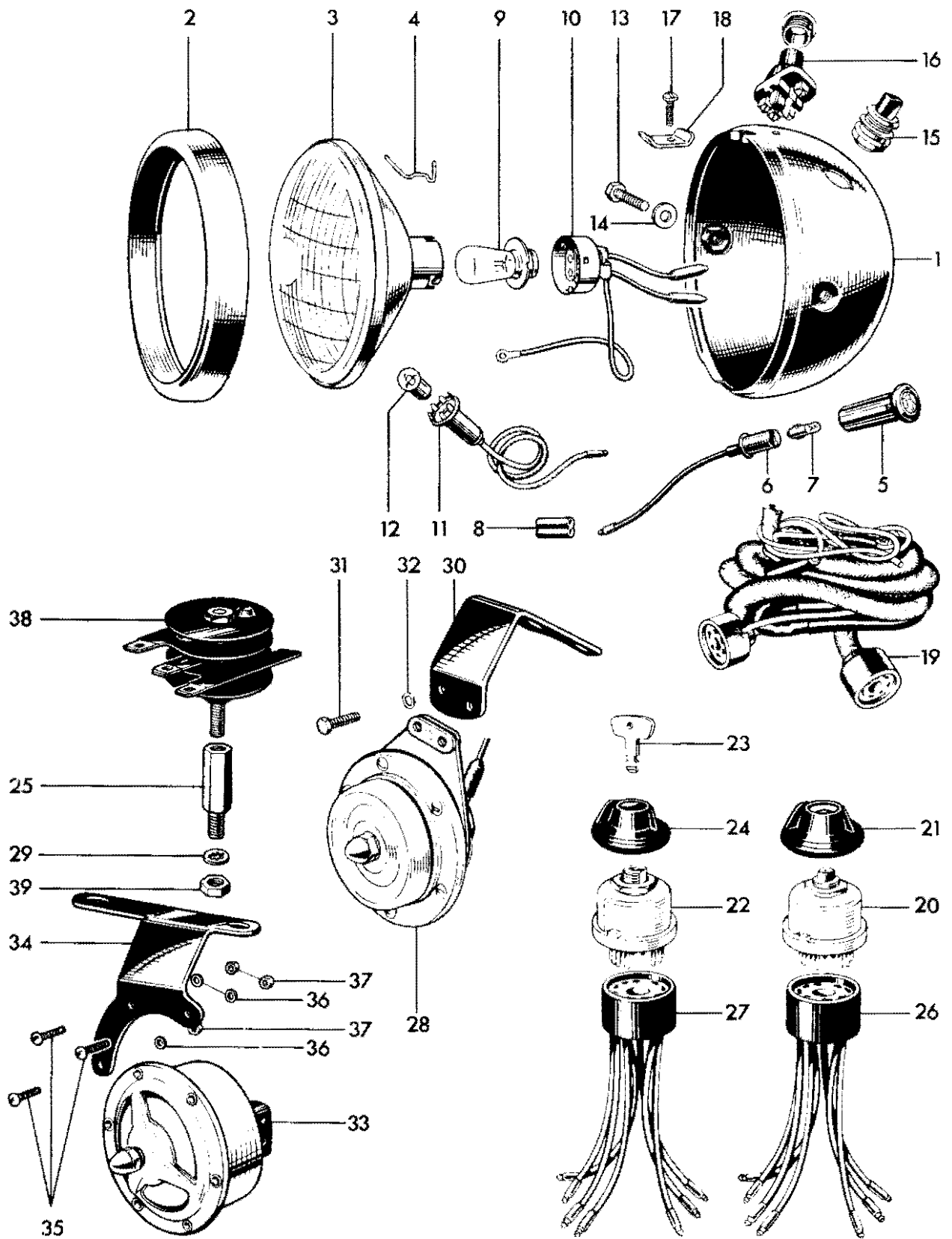

Fig. 19. ELECTRICAL EQUIPMENT

## ELECTRICAL EQUIPMENT

			T20SM	T20SH
1	58395L	HEADLAMP ASSEMBLY, MCH 66 c/w High beam warning	1	-
1	58935F	HEADLAMP ASSEMBLY, MCH 66	-	1
2	534343	Rim	1	1
3	54520452	Light unit	1	-
3	516828	Light unit	-	1
4	504665	Fixing wire	6	6
5	38189	Warning lamp body and lens	1	-
6	54933910	Warning bulbholder	1	-
7	282	Warning bulb, BA 7S, 6V, 0.6W.	1	-
8	850641	Double snap connector	1	-
9	166	Bulb (24/24W. Pre-focus, Vertical Dip)	1	1
10	554602	Adaptor	1	1
11	554710	Pilot bulbholder	-	1
12	988	Bulb (3W. MCC)	-	1
13	112201	Bolt	2	2
14	137499	Washer	2	2
15	31356	Lighting switch	1	-
16	31620	Dip switch	1	1
17	144921	Screw	1	1
18	534296	Plate	1	1
19	54094433	Wiring harness	1	-
19	54933224	Wiring harness	-	1
20	34289	Lighting switch, type 88SA	-	1
21	54330934	Knob c/w screw	-	1
22	34427	IGNITION SWITCH c/w KEY, TYPE 88SA	-	1
23	54336176	Ignition key	-	1
24	54336178	Ignition switch cover	-	1
25	F5431	Extended nut	-	1
26	54930007	Replacement harness socket (lighting)	-	A
27	54930008	Replacement harness socket (ignition)	-	A
28	70178	Horn, type 8H	-	1
29	E2287	Serrated washer	-	1
30	H1429	Bracket	-	1
31	F4771	Bolt ( $\frac{1}{2}$ in. U.H.)	-	2
32	GS299	Serrated washer	-	2
33	70145	Horn, type HF 1950	1	-
34	H1304	Bracket	1	-
35	F5008	Screw ( $\frac{7}{8}$ in. U.H.)	3	-
36	E2880	Serrated washer	3	-
37	H691	Nut	3	-
38	49072	Rectifier, type DS 506	-	1
39	S1-51	Nut	-	1

CONTACT BREAKER  
ASSY. REF. N° 1

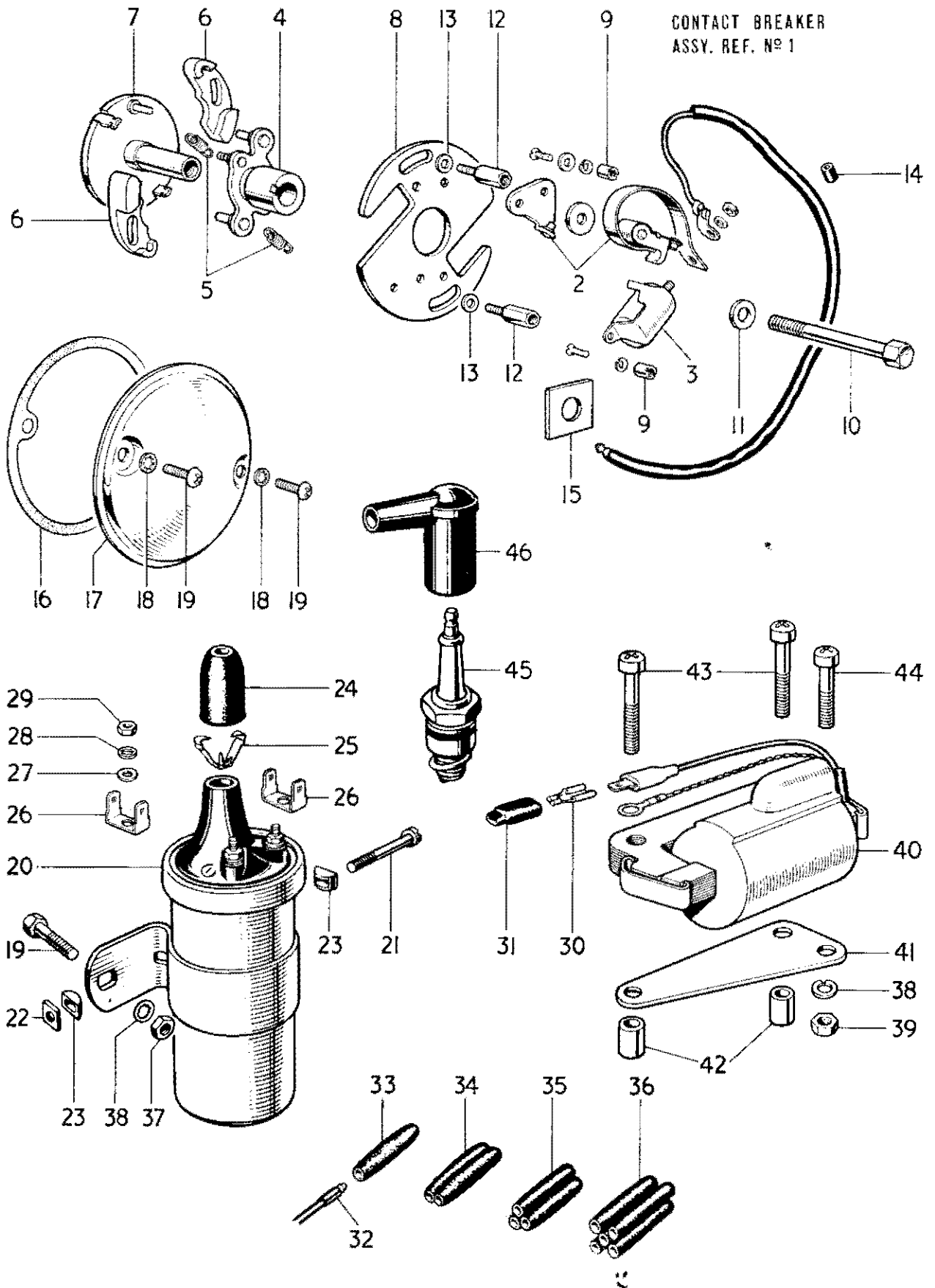

Fig. 20. CONTACT BREAKER AND IGNITION COIL

## CONTACT BREAKER AND IGNITION COIL

			T20SM	T20SH
1	47621	CONTACT BREAKER, type 4CA	—	1
1	47624	CONTACT BREAKER, type 4CA	1	—
2	54415803	Contact set	1	1
3	425377	Condenser	1	1
4	54440029	Cam	—	1
4	54415053	Cam	1	—
5	425768	Spring set	—	1
5	54415640	Spring set	1	—
6	54440031	Weight	2	2
7	54415655	Sleeve and action plate	—	1
7	54415749	Sleeve and action plate	1	—
8	425370	Base plate	1	1
9	169194	Slotted nut	2	2
10	E5451	Bolt (2 in. U.H.)	1	1
11	S25-43	Plain washer	1	1
12	E4747	Pillar bolt ( $\frac{1}{32}$ in. U.H.)	2	2
13	E2351	Plain washer	2	2
14	E4750	Grommet	1	1
15	E5050	Cable clip	1	1
16	E5049	Joint washer	1	1
17	E4571	Cover	1	1
18	GS299	Serrated washer	2	2
19	F4715	Screw ( $\frac{1}{32}$ in. U.H.)	2	2
20	45152	COIL, type MA.6	—	1
21	100104	Clip screw	—	1
22	169160	Square nut	—	1
23	422369	"D" washer	—	2
24	421554	Grommet	—	1
25	421863	Clip	—	1
26	54190108	Lucar terminal	—	2
27	131023	Plain washer (E2351)	—	2
28	188330	Serrated washer (GS299)	—	2
29	166043	Nut (F3799)	—	2
30	54942078	Lucar connector	As required	
31	54190042	Insulating cover	As required	
32	900269	Snap connector terminal	As required	
33	900288	Single snap connector	As required	
34	850641	Double snap connector	As required	
35	850844	Triple snap connector	As required	
36	850832	Quintuple snap connector	As required	
37	DS57	Bolt ( $\frac{7}{8}$ in. U.H.)	—	2
38	E1612	Serrated washer	1	2
39	F879	Nut	1	2
40	45149	Ignition coil, type 3 ET	1	—
41	F5396	Bracket	1	—
42	F4374	Spacer	2	—
43	E3800	Screw ( $\frac{7}{8}$ in. U.H.)	2	—
44	E3668	Screw ( $\frac{1}{2}$ in. U.H.)	1	—
45	—	Sparking plug (Champion L7)	1	1
46	D297	Plug cover and suppressor	—	1
46	D262	Plug cover	1	—

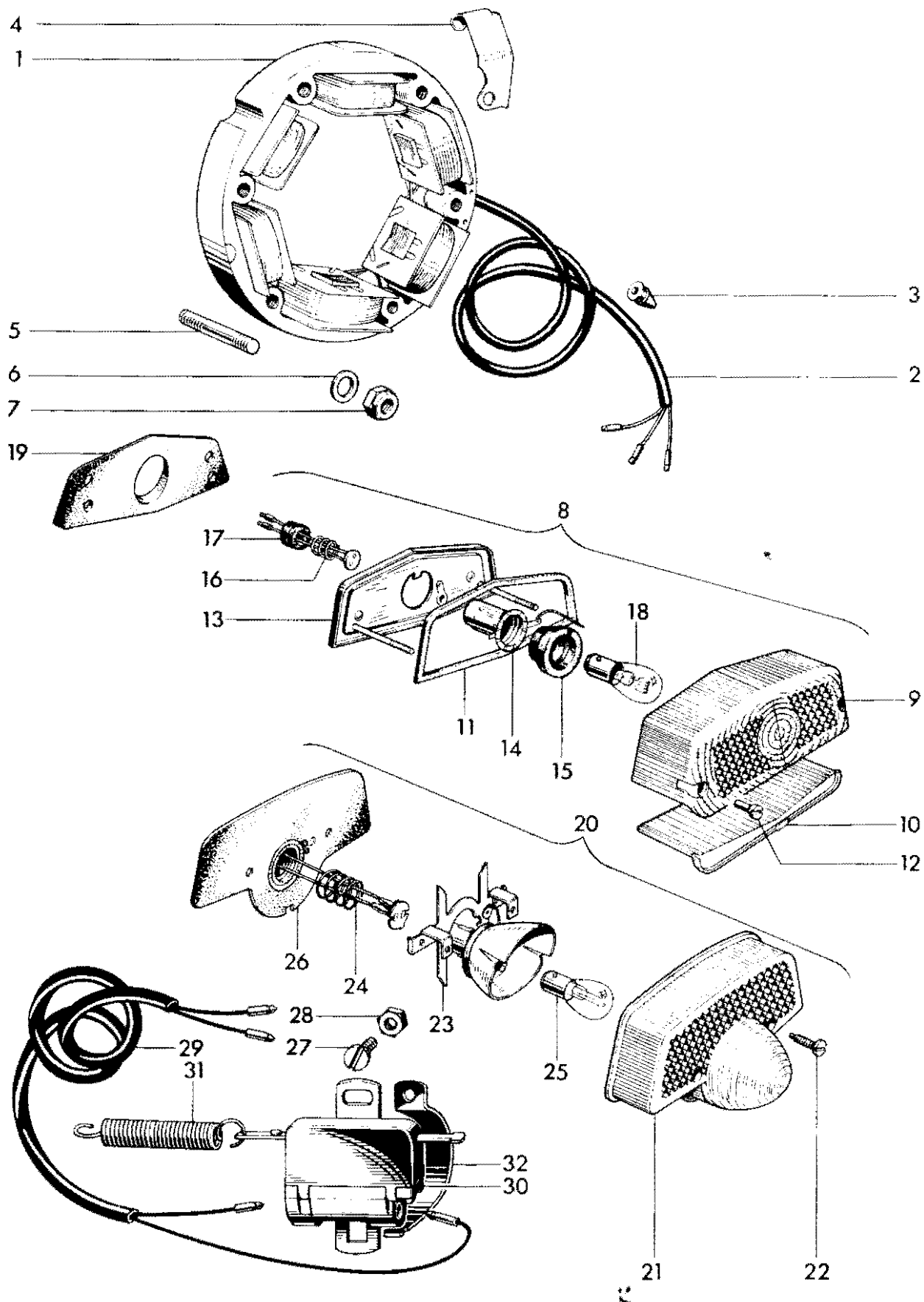

Fig. 21. STATOR, TAIL LAMP AND STOP LAMP SWITCH

## STATOR, TAIL LAMP AND STOP LAMP SWITCH

											T20SM	T20SH
1	47161	STATOR, type RM18	...	...	...	...	...	...	...	...	-	1
1	47188	STATOR, type RM19	...	...	...	...	...	...	...	...	1	-
2	54942271	Stator output cable	...	...	...	...	...	...	...	...	-	1
2	54944251	Stator output cable	...	...	...	...	...	...	...	...	1	-
3	D455	Grommet	...	...	...	...	...	...	...	...	1	1
4	E4485	Clip	...	...	...	...	...	...	...	...	1	1
5	E3171	Stud (1 $\frac{5}{32}$ in. O.A.)	...	...	...	...	...	...	...	...	-	5
5	E3718	Stud (1 $\frac{5}{16}$ in. O.A.)	...	...	...	...	...	...	...	...	5	-
6	E3302	Plain washer	...	...	...	...	...	...	...	...	-	4
6	S25-13	Plain washer	...	...	...	...	...	...	...	...	5	-
7	E5269	Self-locking nut	...	...	...	...	...	...	...	...	5	5
8	53394	STOP AND TAIL LAMP, Type 564	...	...	...	...	...	...	...	...	-	1
9	573839	Lens	...	...	...	...	...	...	...	...	-	1
10	575200	Window	...	...	...	...	...	...	...	...	-	1
11	575208	Lens seating gasket	...	...	...	...	...	...	...	...	-	1
12	575219	Sleeve nut	...	...	...	...	...	...	...	...	-	2
13	576002	Base assembly	...	...	...	...	...	...	...	...	-	1
14	575209	Bulbholder	...	...	...	...	...	...	...	...	-	1
15	575207	Grommet	...	...	...	...	...	...	...	...	-	1
16	573828	Contact assembly	...	...	...	...	...	...	...	...	-	1
17	573825	Grommet	...	...	...	...	...	...	...	...	-	1
18	352	Bulb (3/18W. Offset pin)	...	...	...	...	...	...	...	...	-	1
19	F6437	Adaptor wedge	...	...	...	...	...	...	...	...	-	1
20	53972	STOP AND TAIL LAMP TYPE, L.679	...	...	...	...	...	...	...	...	1	-
21	54572932	Lens	...	...	...	...	...	...	...	...	1	-
22	572289	Screw	...	...	...	...	...	...	...	...	2	-
23	54574348	Bulbholder with reflector	...	...	...	...	...	...	...	...	1	-
24	573828	Contact assembly	...	...	...	...	...	...	...	...	1	-
25	384	Bulb (6/18W. Offset pin)	...	...	...	...	...	...	...	...	1	-
26	54571677	Gasket	...	...	...	...	...	...	...	...	1	-
27	H687	Bolt ( $\frac{3}{8}$ in. U.H.)	...	...	...	...	...	...	...	...	1	1
28	H745	Nut	...	...	...	...	...	...	...	...	1	1
29	54941045	Stop switch lead	...	...	...	...	...	...	...	...	1	1
30	31437	Stop lamp switch	...	...	...	...	...	...	...	...	A	A
31	315738	Stop lamp switch spring	...	...	...	...	...	...	...	...	1	1
32	F4114	Switch bracket	...	...	...	...	...	...	...	...	1	1

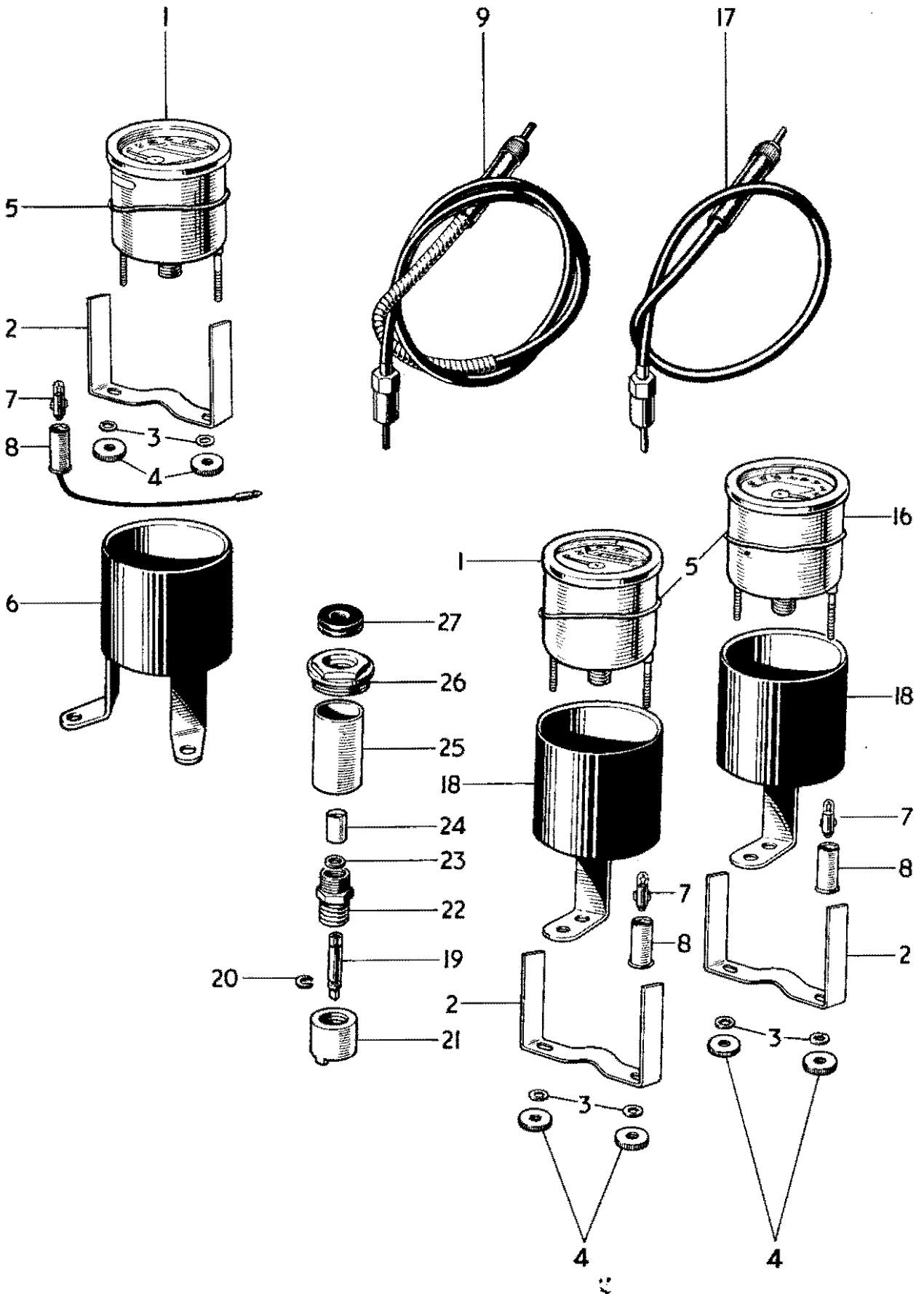

Fig. 22. SPEEDOMETER AND TACHOMETER EQUIPMENT



## SPEEDOMETER AND TACHOMETER EQUIPMENT

SPEEDOMETER EQUIPMENT ONLY			T20SM	T20SH
1	SSM2001/00	SPEEDOMETER 80 M.P.H....	1	1
1	SSM2001/03	SPEEDOMETER 140 K.P.H.	A	A
2	31-647-187-01	Fixing strap	1	1
3	30-283-014-11	Serrated washer	2	2
4	30-271-014-11	Nut	2	2
5	31-753-720	Rubber ring	1	1
6	H1468	Speedometer cover	1	1
7	282	Bulb 0.6W BA7S	1	1
8	54935300	Bulbholder	1	1
9	D634	Speedometer cable (61 ins. long)	1	1
TACHOMETER EQUIPMENT ONLY				
16	RSM2002/00	TACHOMETER HEAD 10,000 R.P.M.	1	1
2	31-647-187-01	Fixing strap	1	1
3	30-283-014-11	Serrated washer	2	2
4	30-271-014-11	Nut	2	2
5	31-753-720	Rubber ring	1	1
6	H1468	Tachometer cover	1	1
7	282	Bulb 0.6W BA7S	1	1
8	54935300	Bulbholder	1	1
17	D529	Tachometer cable	1	1
COMBINED SPEEDOMETER AND TACHOMETER EQUIPMENT				
1	SSM2001/00	SPEEDOMETER 80 M.P.H....	1	1
1	SSM2001/03	SPEEDOMETER 140 K.P.H.	A	A
16	RSM2002/00	TACHOMETER HEAD	1	1
2	31-647-187-01	Fixing strap	2	2
3	30-283-014-11	Serrated washer	4	4
4	30-271-014-11	Nut	4	4
5	31-753-720	Rubber ring	2	2
18	H1605	Instrument cover	2	2
7	282	Bulb 0.6W BA7S	2	2
8	54935300	Bulbholder	2	2
9	D490	Speedometer cable	1	1
17	D529	Tachometer cable	1	1
TACHOMETER DRIVE AT CRANKCASE				
19	D493	Tachometer cable spade	1	1
20	D494	Retaining washer	1	1
21	E4692	Adaptor for crankcase	1	1
22	E5667	UNION	1	1
23	E4803	"O" Ring	1	1
24	E5669	Nylon bush	1	1
25	E4691	Spacer	1	1
26	E4690	Plug	1	1
27	F5332	Grommet	1	1