

TRIUMPH

REPLACEMENT PARTS CATALOGUE

TROPHY 250

TR.25.W.

Trophy 250 1968

TRIUMPH ENGINEERING COMPANY LIMITED
MERIDEN WORKS · ALLESLEY · COVENTRY · ENGLAND
TELEPHONE MERIDEN 331 TELEGRAMS "TRUSTY, COVENTRY"

REF. No. SPC6

PUBLISHED MARCH 1968

79.870

TRIUMPH GUARANTEE

1. In this Guarantee the word "machine" refers to the motor cycle, scooter, motor cycle combination or sidecar as the case may be, purchased by the Purchaser.
2. In order to obtain the benefit of this Guarantee, the Purchaser must have correctly completed the registration form and returned it to us within fourteen days of the purchase.
3. We will supply, free of charge, a new part in exchange for, or, if we consider repair sufficient, will repair free of charge any part proved within six months of the date of purchase of any new machine, (three months overseas) or within three months of its renewal or repair in the case of a part already renewed or repaired, to be defective by reason of our faulty workmanship or materials. We do not undertake to bear the cost of fitting such new or repaired part or accessory.
4. Any part considered to be defective must be sent to our Works, carriage paid, accompanied by the following information:—
 - (a) Name of purchaser and his address;
 - (b) Date of purchase of machine;
 - (c) Name of dealer from whom the purchase was made;
 - (d) Engine number and model.
5. This Guarantee shall not extend to defects or damage appearing after misuse, neglect, abnormal stress or strain, or the incorporation or affixing of unsuitable attachments or parts and in particular:—
 - (a) Hiring out;
 - (b) Racing and Competitions;
 - (c) Adaptation or alteration of any part or parts after leaving our Works;
 - (d) The attaching of a sidecar in a manner not approved by us or to an unsuitable motor cycle.

This Guarantee shall not extend to machines whose trade mark, name or manufacturing number has been altered or removed, or in which has been used any part not supplied or approved by us, or to tyres, saddles, chains, speedometers, revolution counters and electrical equipment or to parts supplied to the order of the Purchaser and different from our standard specification.
6. Our liability and that of our dealer who sells the machine, shall be limited to that set out in this guarantee, and not other claims including claims for consequential damage or injury to person or property, shall be admissible. All other conditions and warranties statutory or otherwise and whether express or implied are hereby excluded and no guarantee other than that expressly herein contained applies to the machine to which this Guarantee relates or any accessory or part thereof.
7. We reserve the right to modify or deviate from the Published Specification without notice.

THE FITTING OF ANY COMPONENTS WHICH ARE NOT APPROVED BY THE MANUFACTURER INVALIDATES THE GUARANTEE

REPAIRS GUARANTEE

1. Whilst the highest standard of workmanship and materials is aimed at, we cannot accept liability for any defects appearing more than three months after the machine, assembly or component has left our Works after being repaired.
2. We will repair or replace at our option free of charge any defective work, materials or parts relating to the repairs carried out by us appearing within that time but shall not be under any further or other liability for any other loss or damage whether direct or consequential and our liability shall be limited to the cost of so making good. We do not undertake to bear the cost of fitting any replacement or repaired part.
3. We do not accept liability in respect of parts of proprietary manufacture, e.g. tyres, saddles, chains, speedometers, revolution counters and electrical equipment which may be used by us in effecting a repair. All other conditions and warranties statutory or otherwise express or implied are hereby excluded.

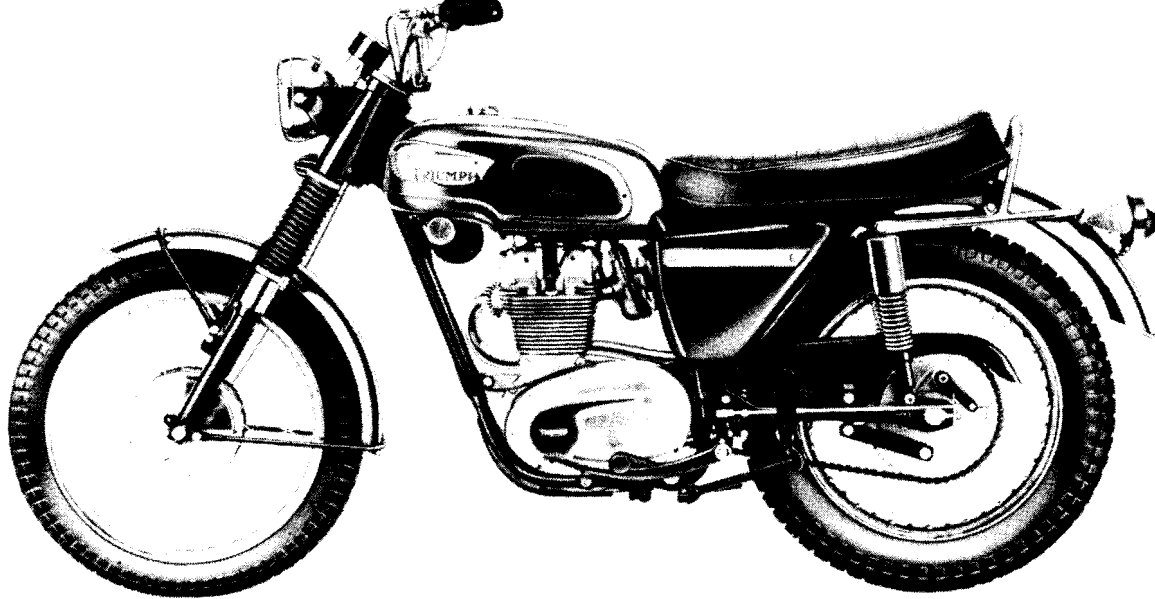

TROPHY 250 TECHNICAL DATA

Bore and stroke	67 x 70 mm.
Capacity	249 c.c.
Compression ratio	10:1
Sparking plug	Champion N3
Carburettor	Amal Concentric .928
Choke size	28 mm.
Main jet	170
Needle jet106
Needle	Standard
Throttle valve	No. 3
Gearbox sprocket	15 teeth
Final Drive Sprocket	52 teeth
Chains	$\frac{3}{8}$ in. x $\frac{7}{32}$ in. Duplex x 70 links
Front	
Rear	$\frac{1}{2}$ in. x $\frac{3}{16}$ in. x 100 links
Capacities	3.916 galls. U.S.
Fuel tank	6 pints
Oil tank	$\frac{1}{2}$ pint
Gearbox	$\frac{1}{4}$ pint
Primary chaincase	$\frac{1}{8}$ pint
Front forks (each leg)	
Brakes	7 in. x $1\frac{1}{8}$ in.
Front and rear diameter	
Tyre size	3.25 x 18
Front	4.00 x 18
Rear	

INDEX

	Page		Page
AIR FILTER	47	HANDLEBARS	39
ALTERNATOR	15, 43	HORN	41
BATTERY CARRIER	23	MUFFLER	27
CARBURETOR	47	OIL PUMP	13
CARTON PACKS	7	OIL TANK	27
CHAINGUARD	25	PILLION FOOTRESTS	29
CHAINS	21, 35	PISTON	9
CLUTCH	21	PROP STAND	25
COIL	41	REAR PANELS	27
CONTACT BREAKER	43	REAR WHEEL	35
CONTROL CABLES	39	RECTIFIER	41
CONTROL LEVERS	39	SPARK PLUGS	11
CRANKCASE	13	SPEEDOMETER	41
CRANKSHAFT	29	STEERING RACES	31
CYLINDER HEAD	49	SUSPENSION UNITS	25
EXHAUST PIPES	27	SWITCHES	41, 43
FENDERS	37	TIMING GEARS	19
FOOTRESTS	29	TOOLKIT	45
FRONT FORKS	31	TWINSEAT	39
FRONT WHEEL	33	VALVES	11
GAS TANK	39	WIRING HARNESS	41
GASKET SETS	7	ZENER DIODE	43
GEARBOX	17, 19		

ILLUSTRATION INDEX

<i>Fig. No.</i>		<i>Page No.</i>
1	CYLINDER AND CRANKSHAFT	8 & 10
2	CRANKCASE	12 & 14
3	GEAR CLUSTER	16 & 18
4	CLUTCH	20
5	FRAME COMPLETE	22
6	SWINGING ARM	24
7	OIL-TANK, PANELS AND EXHAUST SYSTEM	26
8	FOOTRESTS AND BRAKE LINKAGE	28
9	TELESCOPIC FRONT FORK	30
10	FRONT WHEEL	32
11	REAR WHEEL	34
12	FENDERS	36
13	GAS TANK, TWIN SEAT AND HANDLEBARS	38
14	ELECTRICAL EQUIPMENT	40 & 42
15	TOOL KIT	44
16	CARBURETTOR	46

TRIUMPH SPARES

HOW TO ORDER. Every part is indicated by a number, and this should be quoted together with the description. In order to assist customers, dimensions have been given in many cases where parts are similar. Parts where possible have been listed in order of assembly and a number of the illustrations show the assembly order also. With these aids, there should be no difficulty in identifying the parts you require.

ALWAYS HEAD YOUR ORDER WITH THE ENGINE NUMBER, STAMPED ON THE LEFT SIDE OF THE ENGINE JUST BELOW THE CYLINDER, TOGETHER WITH THE PREFIX LETTERS.

WHERE TO OBTAIN. Triumph Spare Parts can only be obtained from an authorised Triumph Dealer, and we recommend our customers to place their orders with the Triumph Dealer in their district. When parts not usually asked for are required, and for which the Dealer may have to write or obtain specially, the postage or carriage incurred becomes payable.

Customers are warned against the risk incurred by purchasing parts that are not of genuine Triumph manufacture. This risk is eliminated if parts are ordered as instructed from recognised Dealers.

PROPRIETARY GROUP

Ancillary equipment which is fitted to our motor cycles is of the highest quality and is guaranteed by the manufacturers and not by ourselves. Any repairs or claims should be directed to the actual makers or their local agents who will always give owners every possible assistance. The following are the addresses of the various manufacturers:—

CARBURETTORS.

Messrs. Amal Ltd.,
Holdford Road,
Witton,
Birmingham, 6

CHAINS.

Reynold Chains Ltd.,
Wythenshawe,
Manchester.

ELECTRICAL EQUIPMENT.

Messrs. J. Lucas Ltd.,
Gt. Hampton Street,
Birmingham, 18.

TYRES.

Dunlop Rubber Co. Ltd.,
Fort Dunlop,
Birmingham, 24

The Avon India Rubber Co. Ltd.,
Melksham,
Wilts.

SPARKING PLUGS.

Champion Sparking Plug Co. Ltd.,
Feltham,
Middlesex.

SPEEDOMETERS.

Messrs. Smiths Industries Ltd.,
Cricklewood Works,
London, N.W.2.

SUSPENSION UNITS.

Messrs. Girling Ltd.,
Birmingham Road,
West Bromwich,
Staffordshire.

HOW TO USE THIS PARTS CATALOGUE

First check that the engine number of your machine is subsequent to that quoted on the title page.

Next consult the index on Page 0 for the parts or group of parts which you wish to locate. When you have located the parts make sure from the end columns that the part you have located does apply to your machine.

List the quantities required as single units; do not ask for "2 pairs" or "3 dozen".

Items marked "reference only" are not available from the factory.

In case of painted items always state the colour. Painted parts are available only in the colours specified for that model of that particular year.

<i>Model</i>	<i>Colour</i>
TR25W	Hi-Fi Scarlet

N.B. Hi-Fi Scarlet is a flamboyant finish applied over Gold.
Paint is available only in Aerosol containers.

PLEASE NOTE

THROUGHOUT THIS LIST, ASSEMBLIES ARE PRINTED IN CAPITALS AND THE COMPONENTS INCLUDED IN THAT ASSEMBLY ARE INDENTED IN THE DESCRIPTION COLUMN, REVERTING TO THE ORIGINAL ALIGNMENT WHEN THE ASSEMBLY IS COMPLETE. TO ORDER THE COMPLETE ASSEMBLY IT IS NECESSARY ONLY TO QUOTE THE ASSEMBLY NUMBER. ANY COMPONENT PARTS LISTED MAY ALSO BE OBTAINED SEPARATELY IF REQUIRED.

SPECIAL WORKSHOP TOOLS

A COMPLETE LIST OF WORKSHOP TOOLS CAN BE MADE AVAILABLE BY EITHER CONTACTING YOUR DEALER OR APPLYING DIRECT TO THE TRIUMPH SERVICE DEPARTMENT. IN MOST CASES THESE TOOLS ARE VERY COSTLY AS THEY ARE MADE ENTIRELY FOR WORKSHOP USE, AND THEREFORE, IT IS NOT RECOMMENDED THAT THE PRIVATE OWNER PURCHASES THE TOOLS IN ORDER TO AID SERVICING THE MACHINE ONCE OR TWICE ONLY. IN THESE CIRCUMSTANCES IT IS FAR MORE ECONOMICAL TO GET IN TOUCH WITH A RECOGNISED DEALER.

UNIFIED THREAD FORM

NEW PARTS HAVING THREADED FIXINGS INTRODUCED IN THIS CATALOGUE HAVE THE UNIFIED FORM OF SCREW THREADS. THIS CHANGEOVER WILL BE CONTINUED AS AND WHEN NEW PARTS ARE INTRODUCED. EVEN WHERE PARTS ARE SIMILAR IN APPEARANCE NEW PART NUMBERS WILL BE ALLOCATED TO IDENTIFY THE UNIFIED THREADS. ALL NUTS, BOLTS AND STUDS HAVING THIS THREAD ARE IDENTIFIED BY MARKINGS. BOLTS HAVE A CIRCULAR RECESS IN THEIR HEADS, STUDS A CIRCULAR GROOVE ON THE END, AND NUTS HAVE INTERLOCKING CIRCLES ON THE SIDE.

CARTON PACK LIST

The following sub-assemblies are supplied in carton packs under the C.P. part number stated. The contents of these carton packs are preserved and will not deteriorate under adverse conditions.

PISTON (complete with rings, gudgeon pin and circlips). These are in effect 'carton pack' assemblies.

E7998	10:1 C.R.	STANDARD SIZE
E8272	10:1 C.R.	0.020 in. oversize
E8273	10:1 C.R.	0.040 in. oversize

PISTON RINGS

CP 211	1	E8276	Top Compression Ring
(Standard size)	1	E8282	Middle Compression Ring
	1	E8279	Scraper Ring

PISTON RINGS

CP211/20	1	E8277	Top Compression Ring
(0.020 in. oversize)	1	E8283	Middle Compression Ring
	1	E8280	Scraper Ring

PISTON RINGS

CP211/40	1	E8278	Top Compression Ring
(0.040 in. oversize)	1	E8284	Middle Compression Ring
	1	E8281	Scraper Ring

OVERHAUL GASKET SET	99-0031
DECOKE GASKET SET	99-0040

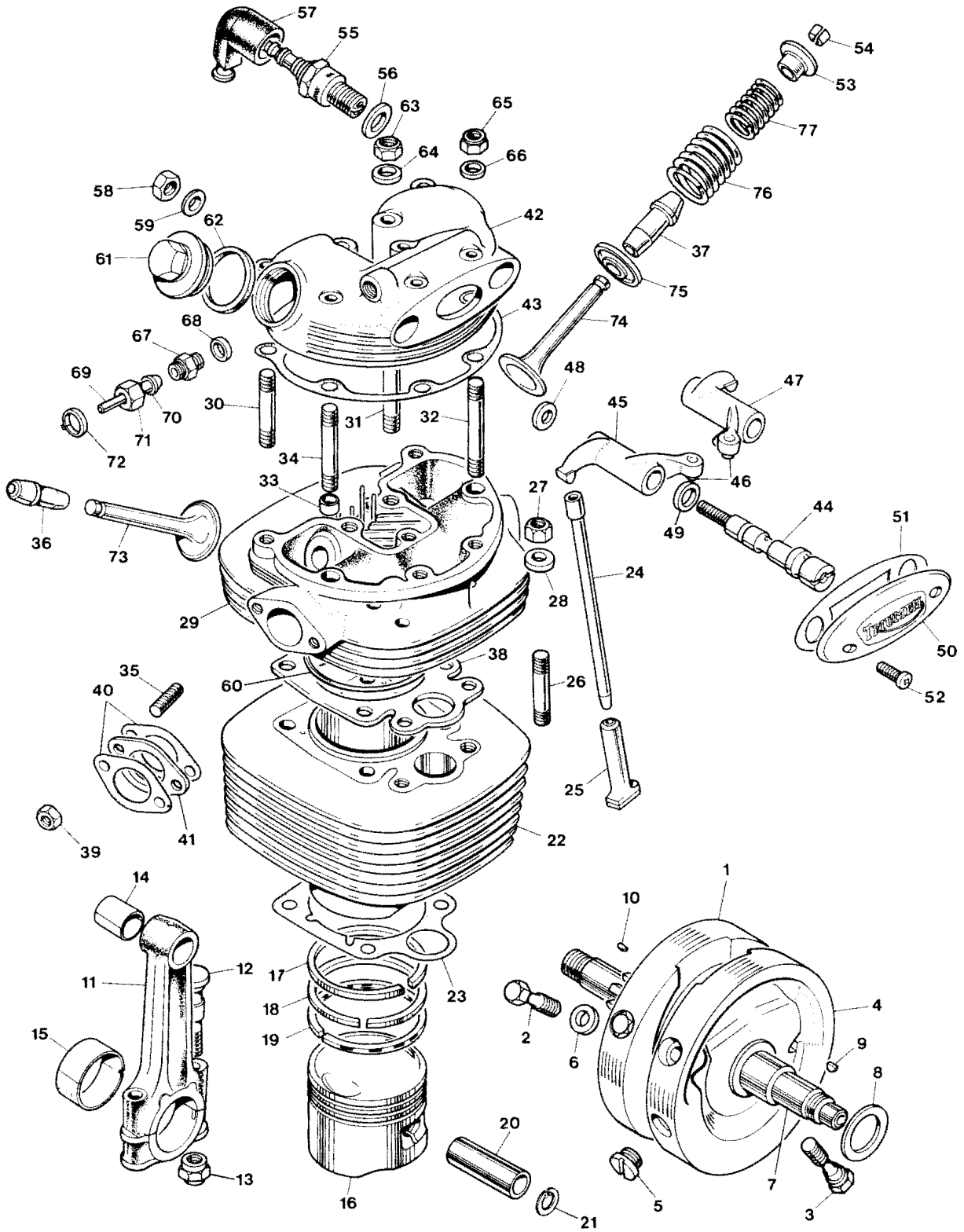

Fig. 1 CYLINDER AND CRANKSHAFT

CYLINDER AND CRANKSHAFT

1	E8031	Flywheel driveside	1
2	E8032	Flywheel bolts upper (1 $\frac{1}{8}$ in. U.H.)	4
3	E8033	Flywheel bolts lower (2 in. U.H.)	4
4	E8034	FLYWHEEL TIMING SIDE	1
5	E8036	Flywheel screwed plug	1
6	E8037	Washer	8
7	E8028	Crankshaft assy.	1
8	E8038	Shim	A.R.
8	E8039	Shim	A.R.
9	E1580	Crankshaft pinion key	1
10	E8144	Rotor key	1
11	E8836	CONNECTING ROD	1
12	E3705	Connecting rod bolt	2
13	E2922	Self-locking nut	2
14	E4003	Small end bush (split)	1
15	E6068	Big end bush	2 halves
16	E7998	PISTON COMPLETE	1
17	E8044	Plain compression ring	1
18	E8047	Taper compression ring	1
19	E8050	Oil control ring	1
20	WE203E	Gudgeon pin	1
21	WE479	Circlip	2
22	E1895	Cylinder barrel	1
23	E7728	Cylinder base washer	1
24	E8053	Push rod (exhaust)	1
24	E8055	Push rod (inlet)	1
25	E7739	Cam follower	2
26	E8008	Cylinder barrel stud	2
27	E8196	Stud nut	2
28	E8215	Washer	2
29	E8197	CYLINDER HEAD	1
30	E8228	Stud—short (2 $\frac{7}{16}$ in. O.A.)	2
31	E8229	Stud	2
32	E8079	Stud—long (3 $\frac{1}{16}$ in. O.A.)	3
33	E8010	Dowel	2
34	E8080	Stud (2 $\frac{1}{16}$ in. O.A.)	2
35	E8227	Carburettor stud (1 $\frac{3}{8}$ in. O.A.)	2
36	E8225	Valve guide (inlet)	1
37	E8226	Valve guide (exhaust)	1
38	E8081	Cylinder head gasket	1
39	E8137	Carburettor stud nut	2
40	E8136	Carburettor flange washer	1
41	E7820	Distance piece	1

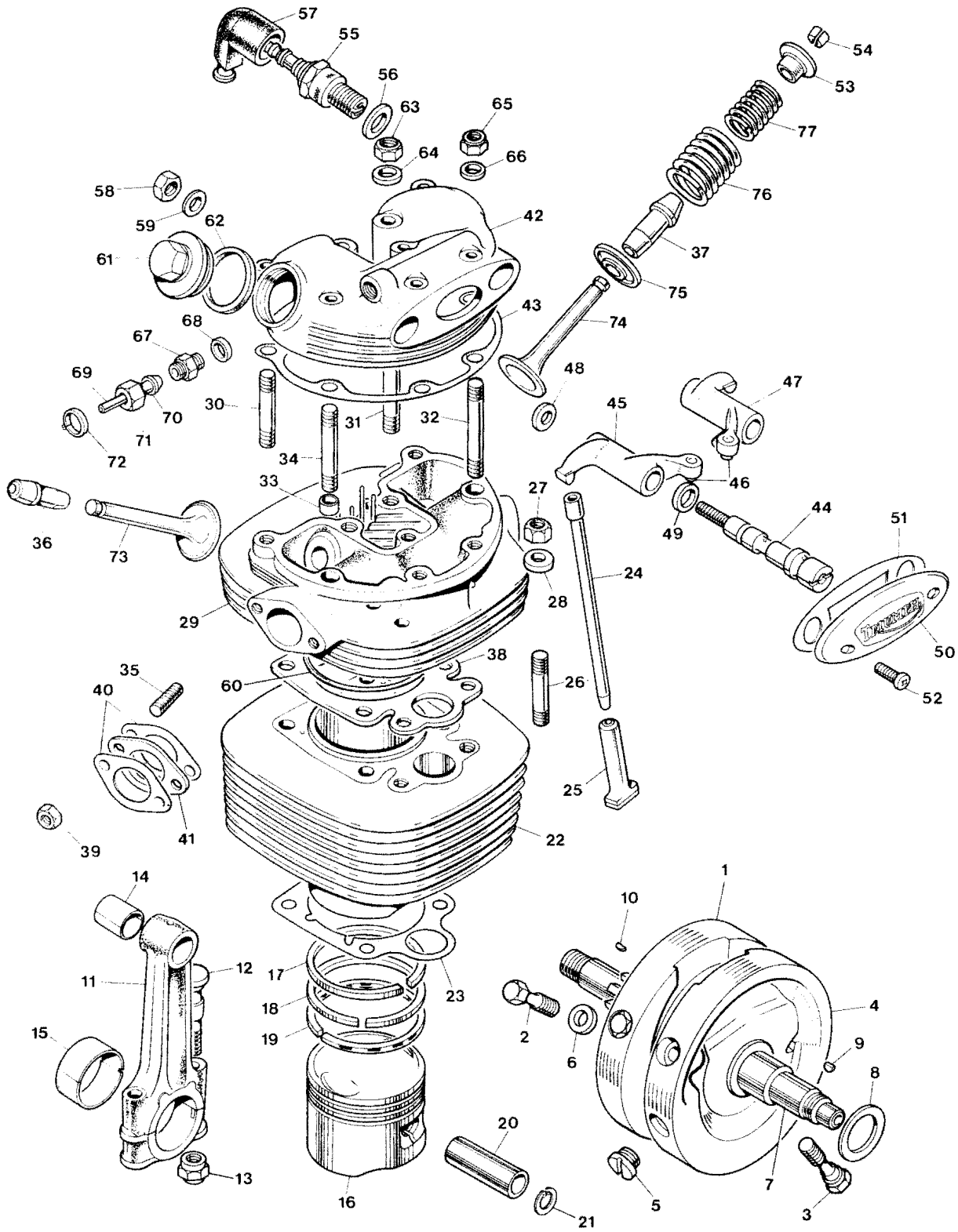

Fig. 1 CYLINDER AND CRANKSHAFT

CYLINDER AND CRANKSHAFT

Ref. No.	Part No.	DESCRIPTION	QUANTITY
42	E7911	Rocker box	1
43	E7858	Rocket box gasket	1
44	E7787	Rocker spindle	2
45	E7790	INLET ROCKER	1
46	E1483	Ball end	1
47	E7791	EXHAUST ROCKER	1
46	E1483	Ball end	1
48	E1575	Thrust washer	2
49	E1330	Thrust washer	2
50	E8952	Inspection cover	1
51	E8085	Gasket	1
52	E8086	Screw ($\frac{1}{8}$ in. U.H.)	2
53	E8116	Top collar	7
54	E8117	Split collet	4 halves
55	N4	SPARK PLUG (N4)	1
56	E8138	Washer	1
57	D1002	Plug cover	1
58	14-0403	Locknut	2
59	E8084	Washer	2
60	E7958	Corrugated ring	A.R.
60	E7959	Corrugated ring	A.R.
60	E7960	Corrugated ring	A.R.
61	E1564	Inspection Cap	2
62	E1577	Washer	2
63	E8087	Nut	2
64	E8088	Washer	2
65	E8089	Nut	7
66	E8072	Washer	7
67	E8082	Union	1
68	E8083	Fibre washer	1
	E8105	OIL FEED PIPE	1
69	E8106	Rubber connection	1
70	E8107	Nipple	1
71	E8110	Union nut	1
72	E8111	Clip	1
73	E8112	Inlet valve	1
74	E7777	Exhaust valve	1
75	E8113	Bottom cup	2
76	E8114	Valve spring—outer	2
77	E8115	Valve spring—inner	2

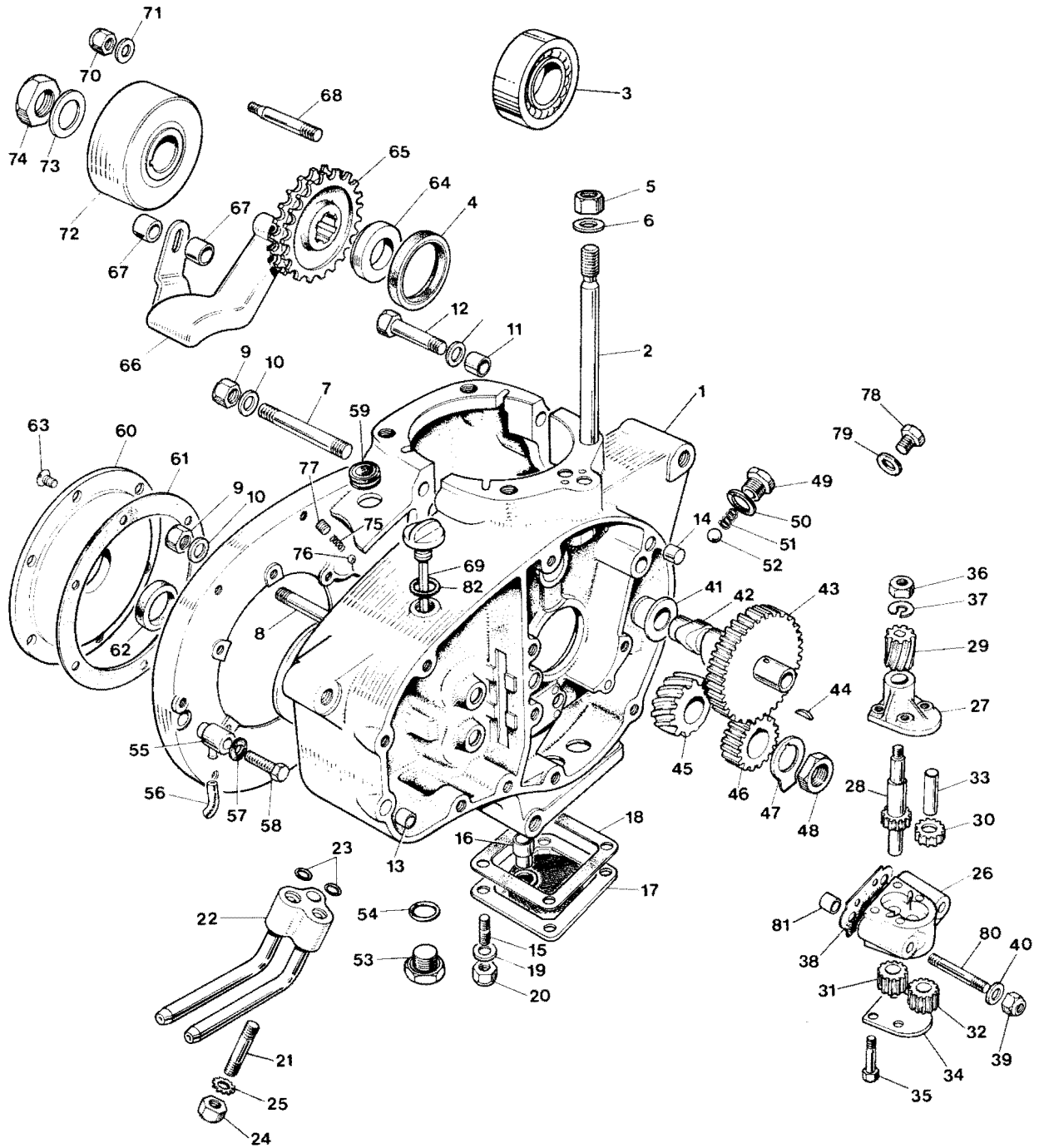

Fig. 2 CRANKCASE

CRANKCASE

1	E8000	CRANKCASE COMPLETE	1
2	E8006	Cylinder securing stud	4
3	E8003	Crankcase bearing	2
4	E8025	Crankcase oil seal	1
5	14-0303	Cylinder securing nut	4
6	E8135	Washer	4
7	E8007	Crankcase stud—top ($2\frac{2}{3}$ in. O.A.)	2
8	E8008	Crankcase stud—rear ($2\frac{1}{8}$ in. O.A.)	2
9	E8133	Nut	4
10	E8088	Washer	7
11	E8009	Dowel	1
12	E8016	Crankcase bolt	3
13	E8010	Hollow dowel	1
14	E8011	Solid dowel	2
15	E8012	Sump stud	4
16	E8017	Scavenge pipe complete	1
17	E8064	Sump cover	1
18	E8070	Gasket	1
19	E8072	Plain washer	4
20	E8071	Nut	4
21	E8013	Oil union stud ($1\frac{7}{8}$ in. O.A.)	1
22	E8127	Oil pipes and union block	1
23	E8132	'O' ring	2
24	E8133	Union nut	1
25	E8134	Washer	1
26	E8090	OIL PUMP COMPLETE	1
27	E8092	Spindle housing	1
28	E8093	Spindle	1
29	E8094	Spindle gear	1
30	E8095	Feed gear—driven	1
31	E8096	Scavenge gear—driving	1
32	E8097	Scavenge gear—driven	1
33	E8098	Driven gear spindle	1
34	E8099	Bottom plate	1
35	E8100	Screw	4
36	E8071	Spindle gear nut	1
37	F9041	Spindle gear washer	1
38	E8103	Gasket	1
39	E8071	Holding nut	2
40	E8104	Washer	2
41	E8004	Camshaft bush	1
42	E8059	Camshaft	1
43	E8060	Camshaft pinion	1

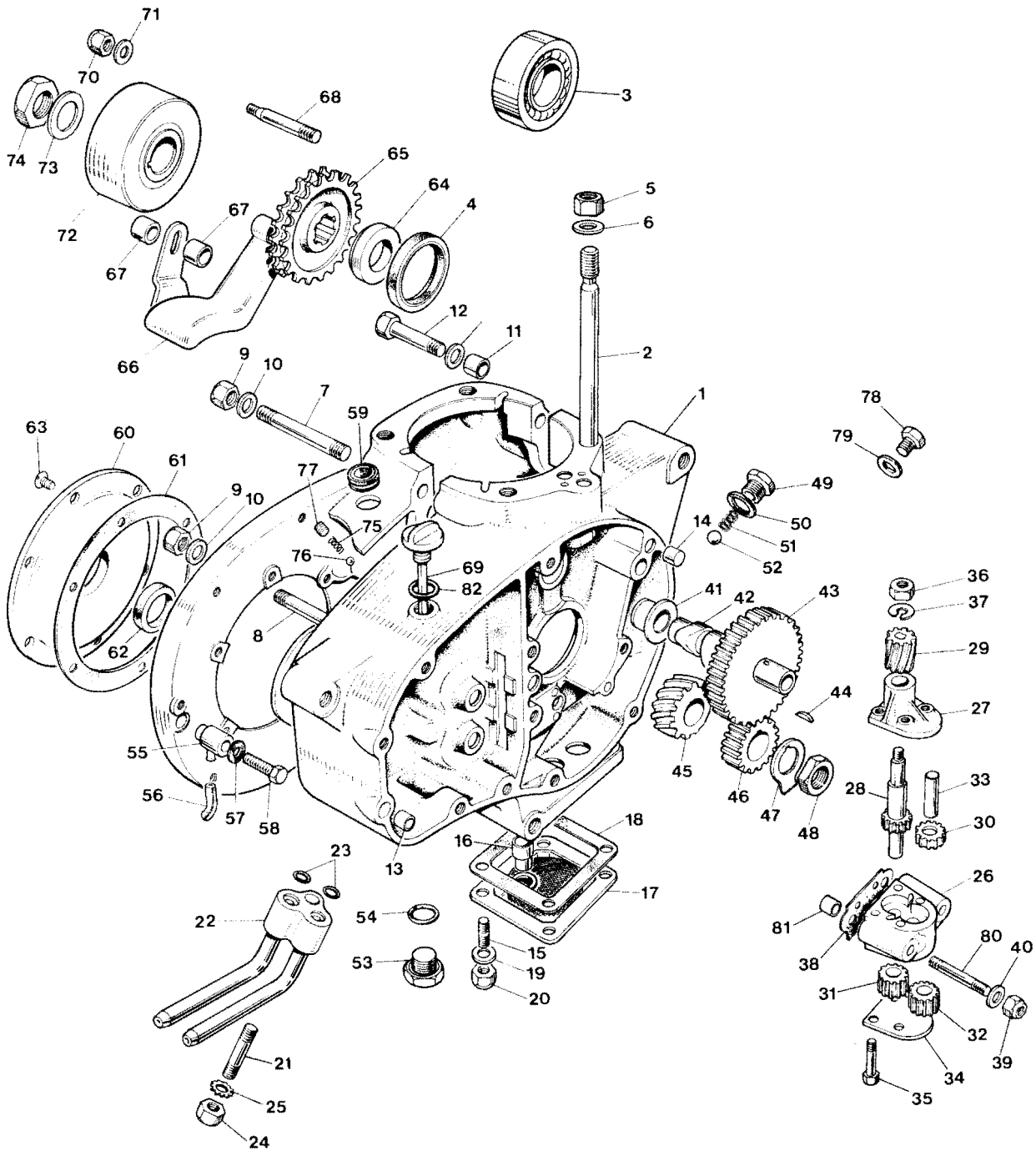

Fig. 2 CRANKCASE

CRANKCASE

44	E8061	Woodruff key	1
45	E8041	Drive gear	1
46	E8040	Crankshaft pinion	1
47	E8043	Lockwasher	1
48	E8042	Nut	1
49	E8123	Pressure release valve plug	1
50	E8121	Plug washer	1
51	E8120	Spring	1
52	E8122	Ball	1
53	T2696	Gearbox drain plug	1
54	T2697	'O' ring	1
55	E8179	Chain oiler	1
56	E8173	Rubber pipe	1
57	E8180	Fibre washer	1
58	E8181	Bolt (1¼ in. U.H.)	1
59	E8148	Generator lead grommet	1
60	E3789	Oil seal housing	1
61	E3832	Gasket	1
62	E3833	Oil seal	1
63	E3821	Screw	6
64	E8140	Distance piece	A.R.
64	E8141	Distance piece	A.R.
64	E8142	Distance piece	A.R.
65	E8139	Engine sprocket (23T)	1
66	E8144	Chain tensioner	1
67	E8143	Distance piece	2
68	E7779	Generator stud—rear (2½ in.)	1
68	E7778	Generator stud—front (2½ in.)	1
68	E8026	Generator stud—bottom	1
69	T2695	Dipstick	1
70	E8071	Nyloc nut	3
71	E8072	Washer	3
72	99-0739	Rotor	1
73	E8224	Lockwasher	1
74	E8146	Nut	1
75	E8124	Non-return valve spring	1
76	E8125	Valve ball	1
77	E8126	Valve screw	1
78	E7885	Sealing plug	1
79	E8159	Washer	1
80	E8288	Stud (2¾ in. O.A.)	2
81	E8022	Dowel	2
82	T948	'O' Ring for dipstick	1

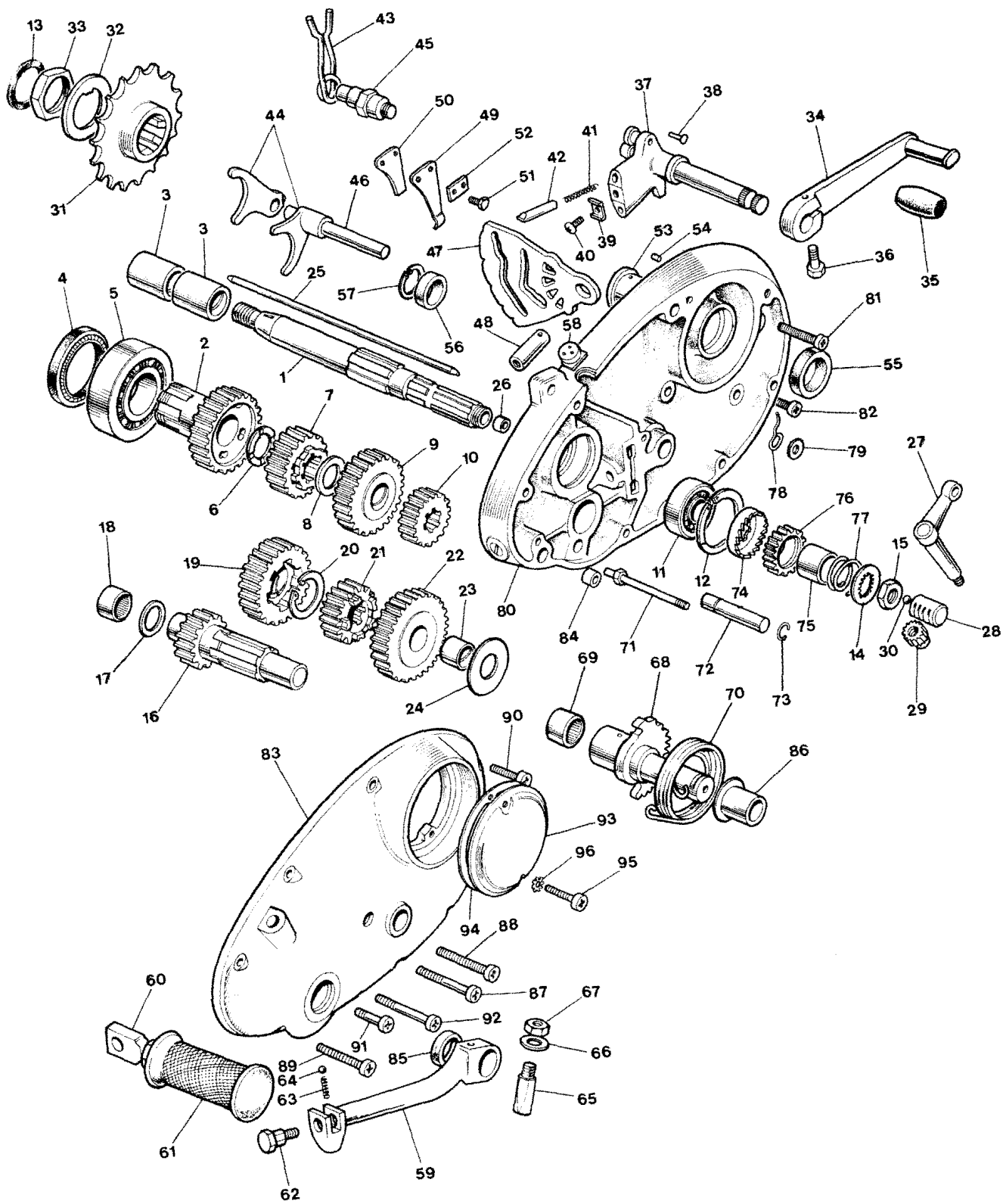

Fig. 3 GEAR CLUSTER

GEAR CLUSTER

1	T2661	Mainshaft complete with bush	1
2	T2676	HIGH GEAR (22T)	1
3	T2753	High gear bush	2
4	E8015	Mainshaft oil seal	1
5	E8014	Mainshaft bearing	1
6	T2678	Thrust washer	A.R.
6	T2679	Thrust washer	A.R.
6	T2680	Thrust washer	A.R.
7	T2673	Mainshaft second gear (21T)	1
8	T2664	Spacer	A.R.
8	T2665	Spacer	A.R.
8	T2666	Spacer	A.R.
9	T2662	Mainshaft third gear (24T)	1
10	T2663	Mainshaft low gear (16T)	1
11	E8151	Mainshaft bearing	1
12	E8152	Bearing circlip	1
13	T2677	Felt washer	1
14	T2685	Lockwasher	1
15	T2686	Mainshaft nut	1
16	T2667	Layshaft and high gear (14T)	1
17	T2671	Thrust washer	1
17	T2672	Thrust washer	1
18	E8005	Layshaft bearing	1
19	T2668	Layshaft second gear (22T)	1
20	T2669	Layshaft circlip	1
21	T2674	Layshaft third gear (19T)	1
22	T2675	LAYSHAFT LOW GEAR COMPLETE (27T)	1
23	T2752	Low gear bush	1
24	T2670	Spacing shim	1
25	T2733	Clutch push rod	1
26	T1391	Push rod bush	1
27	T2750	Clutch lever complete	1
28	T2699	Clutch operating rack	1
29	T2700	Clutch operating pinion	1
30	E8019	Thrust ball	1
31	T2765	Gearbox sprocket (15T)	1
31	T2701	Gearbox sprocket (16T)	Alternative
31	T2766	Gearbox sprocket (17T)	Alternative
32	T2702	Lockwasher	1
33	T1434	Nut	1
34	T1164	Gear change pedal	1
35	T2450	Pedal rubber	1
36	T2703	Pedal bolt ($\frac{1}{8}$ in. U.H.)	1

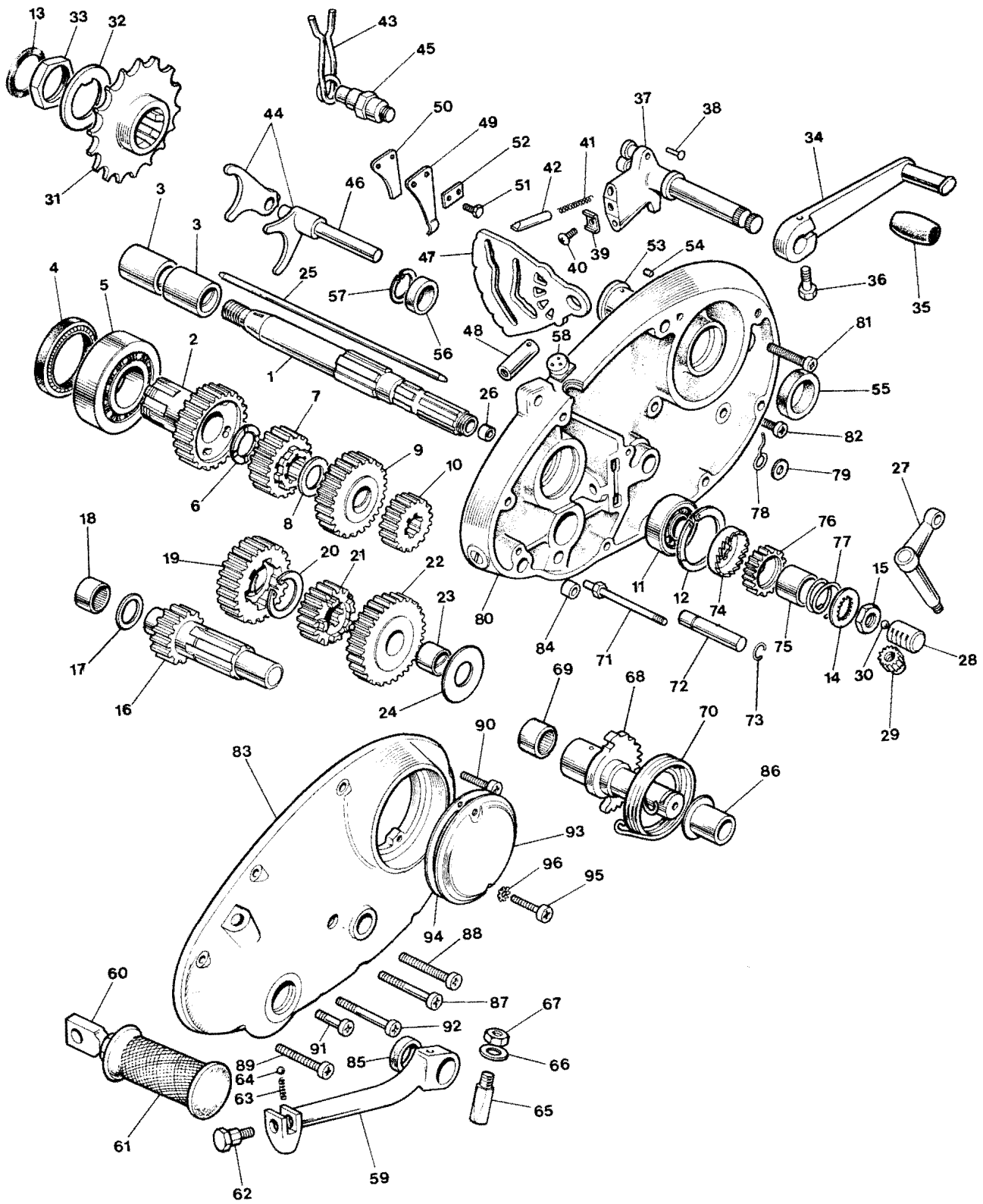

Fig. 3 GEAR CLUSTER

GEAR CLUSTER

	T2692	GEARCHANGE QUADRANT COMPLETE	1
37	T2693	Gearchange quadrant	1
38	T1277	Spring rivet	2
39	T2107	Keeper plate	1
40	T2435	Screw	1
41	T2106	Spring	2
42	T2105	Plunger	2
43	T1109	Return spring	1
44	T2689	Selector fork	2
45	T2659	Anchor bolt	1
46	T2688	Selector spindle	1
47	T2690	Camplate	1
48	T1069	Camplate spindle	1
49	T2691	Index spring	1
50	T1249	Spring backing	1
51	T1076	Screw	2
52	T1180	Lockplate	1
53	E8150	Camshaft bush	1
54	E3172	Peg	1
55	E8153	Camshaft oil seal	1
56	E8154	Crankshaft T/S oil seal	1
57	E8157	Oil seal circlip	1
58	E8155	Cable grommet	1
59	T2763	KICKSTART CRANK COMPLETE	1
60	T2774	Kickstart folding pedal	1
61	T2330	Pedal rubber	1
62	T1169	Pivot bolt (1 in U.H.)	1
63	T1167	Spring	1
64	E8125	Steel ball	1
65	T2704	Cotter pin	1
66	T2705	Cotter washer	1
67	T2706	Cotter nut	1
68	T2643	KICKSTART SPINDLE	1
69	E8005	Needle roller	1
70	T2687	Return spring	1
71	T2660	Anchor pin	1
72	T2657	Kickstart stop	1
73	T2658	Circlip	1
74	E2681	Kickstart ratchet	1
75	E2682	Bush	1
76	T2683	Pinion	1
77	T2684	Spring	1
78	E8172	Contact breaker clip	1
79	E8072	Washer	1
80	E7919	Inner timing cover	1
81	E8160	Inner cover screw—short	5
82	E8161	Inner cover screw—bottom front	2
83	E8232	OUTER TIMING COVER	1
84	E8010	Dowel	2
85	T2641	Kickstart oil seal	1
86	T2642	Bush	1
87	E8167	Outer cover screw	3
88	E8168	Outer cover screw	1
89	E8160	Inner cover screw	4
90	E8169	Outer cover screw ($\frac{5}{8}$ in. U.H.)	3
91	E8170	Inner cover screw ($\frac{1}{8}$ in. U.H.)	1
92	E8171	Outer cover screw ($2\frac{3}{8}$ in. U.H.)	1
93	E8737	Cover	1
94	E7882	Gasket	1
95	E7354	Screw ($\frac{1}{2}$ in. U.H.)	2
96	E8165	Serrated washer	2

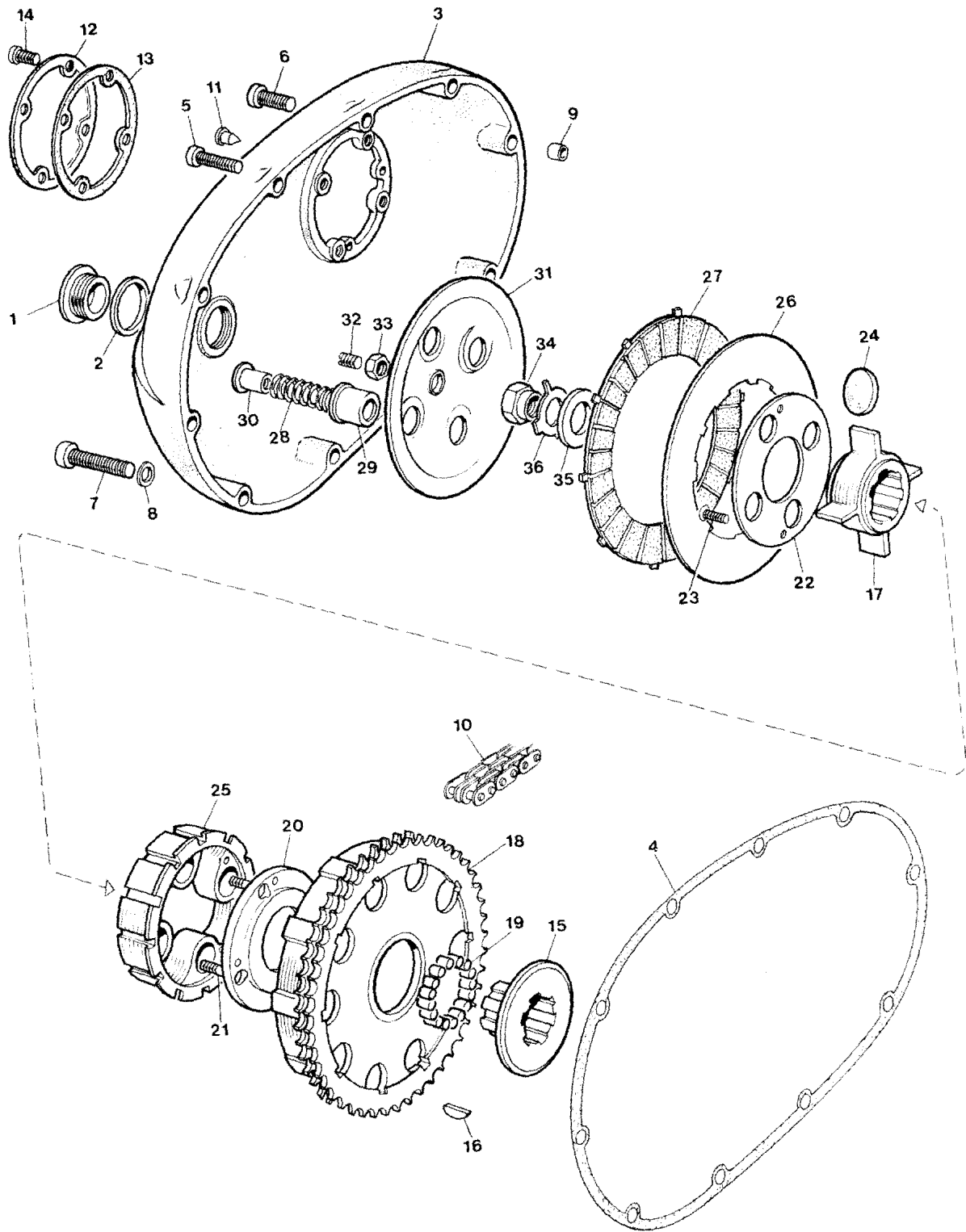

Fig. 4 CLUTCH

CLUTCH

1	E8231	Filler plug	2
2	NE507	Fibre washer	2
3	E8953	Primary chaincase cover	1
4	E7856	Chaincase gasket	1
5	E8168	Cover screw	4
6	E8160	Cover screw	5
7	E8174	Drain plug	1
8	E8175	Washer	1
9	E8010	Chaincase dowel	2
10	D951	Primary chain (70L.)	1
11	E8176	Ignition pointer screw	1
12	E8955	Inspection cover	1
13	E8178	Gasket	1
14	E8177	Screw ($\frac{1}{2}$ in. U.H.)	4
15	T2713	Clutch hub	1
16	T2714	Clutch hub key	1
17	T2715	Clutch spider	1
18	T2716	Sprocket and housing	1
19	T2719	Roller	25
20	T2720	INNER RETAINING PLATE	1
21	Reference only	Spring stud	4
22	T2721	Outer retaining plate	1
23	T2722	Screw	4
24	T2723	Shock absorber—drive and rebound	8
25	T2724	Centre	1
26	T2725	Driven plate	5
27	T2726	Driving plate	4
28	T2727	Spring	4
29	T1144	Cup	4
30	T2748	Spring nut	4
31	T2728	Pressure plate	1
32	T2729	Adjuster	1
33	F879	Locknut	1
34	T2730	Retaining nut	1
35	T2731	Plain washer	1
36	T2732	Lockwasher	1

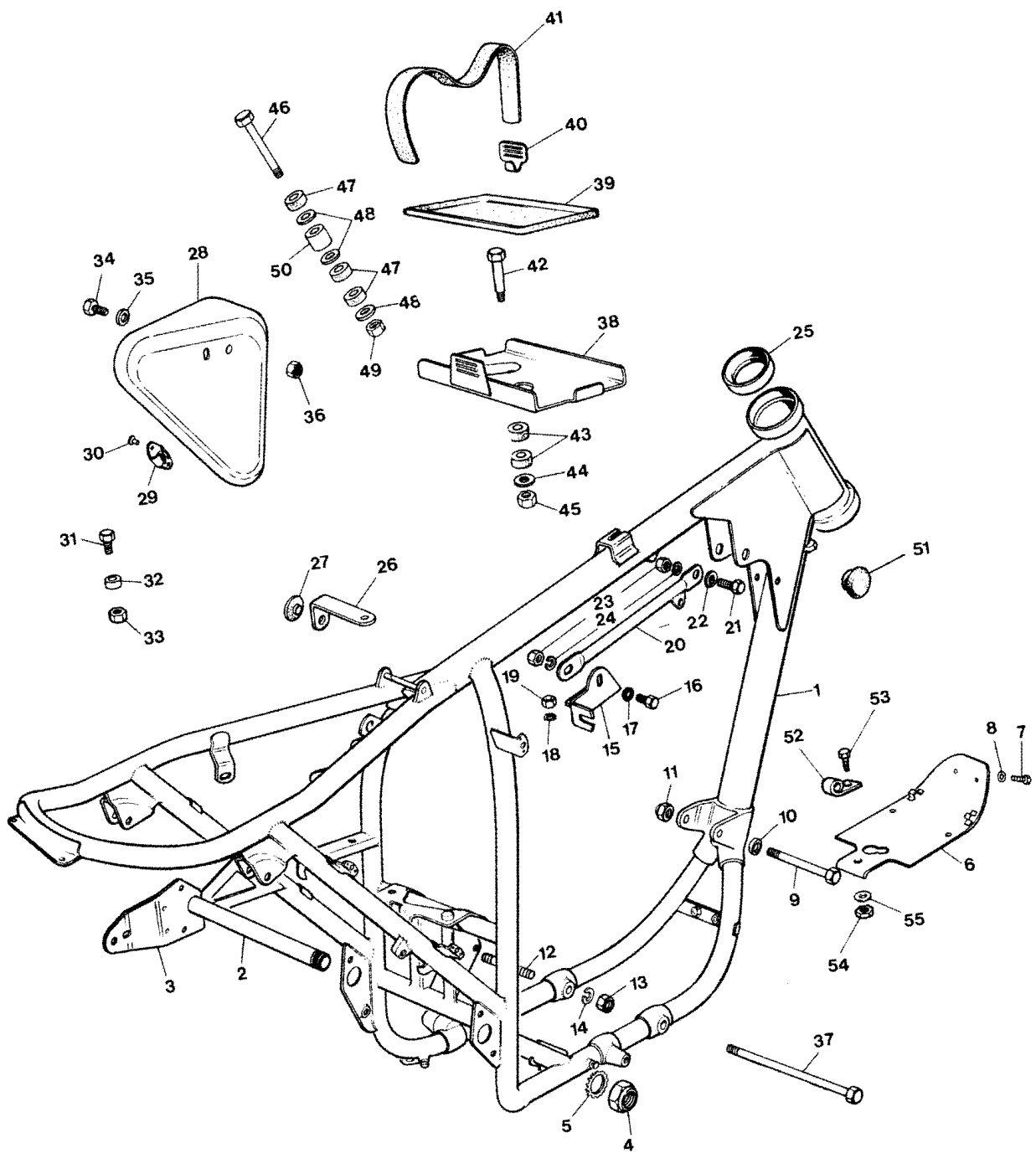

Fig. 5 FRAME COMPLETE

FRAME COMPLETE

1	F8451	Frame	1
2	F8994	SWINGING ARM SPINDLE	1
3	Reference only	Spindle locking plate	1
4	F8995	Spindle nut	1
5	F8996	Shakeproof washer	1
6	F8819	Engine shield	1
7	F9029	Bolt ($\frac{1}{2}$ in. U.H.)	2
8	E8134	Shakeproof washer	2
9	F8984	Front engine fixing bolt ($3\frac{3}{16}$ in. U.H.)	1
10	E8084	Spacer	2
11	E8194	Nut	2
12	F8985	Rear stud ($2\frac{9}{16}$ in. O.A.)	1
13	F8987	Rear nut	2
14	F8986	Washer	2
15	E8189	Steady bracket	1
16	F5535	Bolt	1
17	S25-2	Washer	1
18	E8134	Shakeproof washer	2
19	E8133	Nut	2
20	F9745	Engine steady stay	1
21	F5535	Bolt	3
22	E8084	Plain washer	3
23	E8194	Nut	3
24	E8191	Shakeproof washer	3
25	F8988	Steering race cup	2
26	F9094	Bracket	1
27	F9093	Rubber buffer	1
28	F9090	Tool tray	1
29	Reference only	Fastener clip	6
30	Reference only	Pop rivet	12
31	F9091	Bolt (.641 in. U.H.)	1
32	F9092	Spacer	1
33	E8071	Nut	1
34	F9060	Bolt ($\frac{3}{8}$ in. U.H.)	1
35	E8072	Washer	1
36	E8071	Nut	1
37	F8989	Bottom bolt	1
38	F8285	Battery carrier	1
39	F9003	Battery tray rubber	1
40	F9004	Hook	1
41	F9005	Battery strap	1
42	F9006	Bolt	2
43	F9007	Mounting rubber	4
44	F9008	Washer	2
45	E8137	Nut	2
46	F9086	Bolt (3 in. U.H.)	1
47	F9007	Mounting rubber	4
48	F9010	Washer	3
49	E8194	Nut	1
50	F9087	Spacer	1
51	F9222	Tank anti-roll rubber	2
52	F9084	'P' clip	1
53	F9023	Bolt ($\frac{1}{16}$ in. U.H.)	1
54	W1691	Nut	1
55	E8088	Washer	1

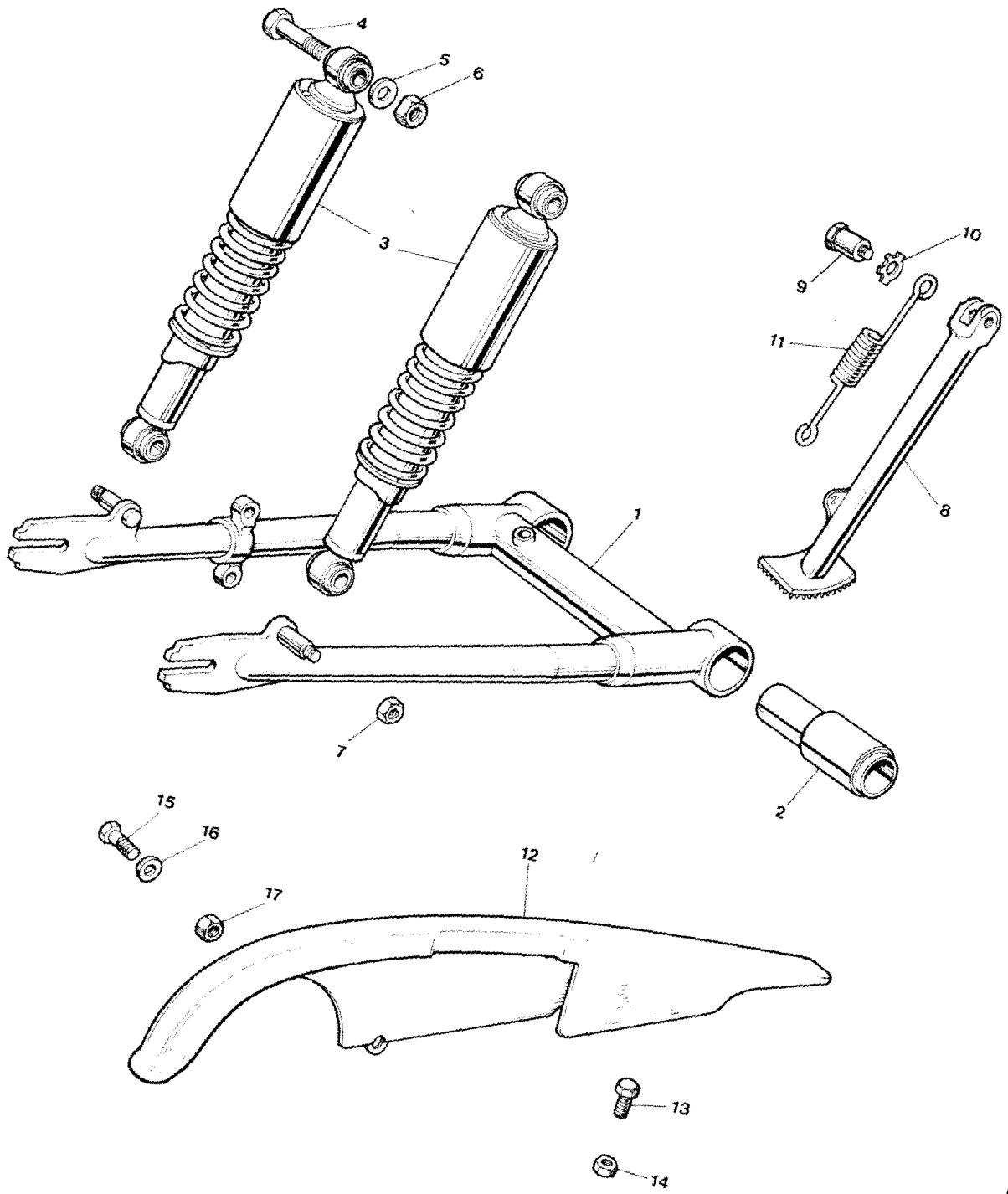

Fig. 6 SWINGING ARM

SWINGING ARM

1	F8992	Swinging arm	1
2	F8993	Silentbloc	2
3	F8876	Suspension unit	2
4	F8997	Unit fixing bolt	2
5	F8998	Plain washer	2
6	F8999	Nut	2
7	F9085	Nut	2
8	F9766	Propstand...	1
9	F3097	Swivel pin	1
10	F3096	Lockwasher	1
11	F2610	Spring	1
12	F9059	Chainguard	1
13	F9060	Bolt	1
14	E8071	Nut	1
15	V2336	Bolt	1
16	E8084	Plain washer	1
17	F9085	Nut	1

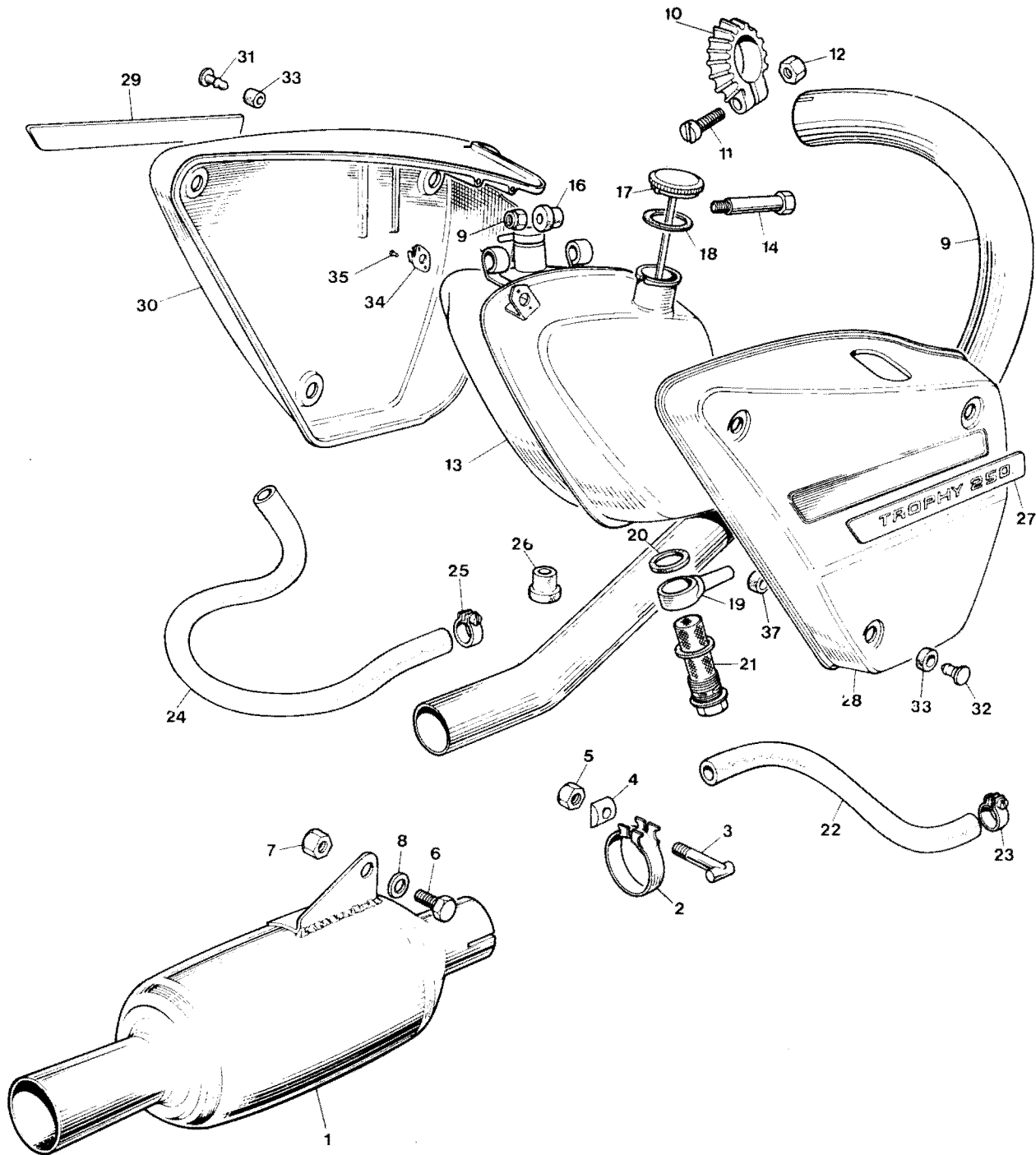

Fig. 7 OIL-TANK, PANELS AND EXHAUST SYSTEM

OIL TANK, PANELS AND EXHAUST SYSTEM

1		Muffler	1
2	F8975	FIXING CLIP	1
3	F9128	Pin	1
4	F9129	Swivel	1
5	S5102	Nut	1
6	14-0114	Bolt	1
7	14-0702	Nut	1
8	F8981	Plain washer	1
9	E9514	Exhaust pipe	1
10	F8976	Finned clip	1
11	F8977	Screw ($\frac{13}{16}$ in. U.H.)	1
12	F8978	Nut	1
13	F9743	Oil tank	1
14	F9067	Bolt ($1\frac{3}{4}$ in. U.H.)	2
15	F9068	Nut	2
16	F6039	Rubber sleeve	2
17	F9075	Filler cap c/w dipstick	1
18	F9076	Filler cap washer	1
19	F8874	Banjo	1
20	F9070	Fibre washer	2
21	F9071	Filter	1
22	F9146	Rubber connection	1
23	F9073	Clip	2
24	F9124	Rubber connection	1
25	E5473	Clip	2
26	F1927	Sleeve	1
27	D1922	Panel motif D/S	1
28	F9477	Panel D/S	1
29	D1923	Panel motif T/S	1
30	F9478	Panel T/S	1
31	D1006	Oddie stud—long	3
32	D982	Oddie stud—standard	1
33	D893	Stud rubber	3
33	D984	Stud rubber	1
34	Reference only	Fastener clip	2
35	Reference only	Rivet	4

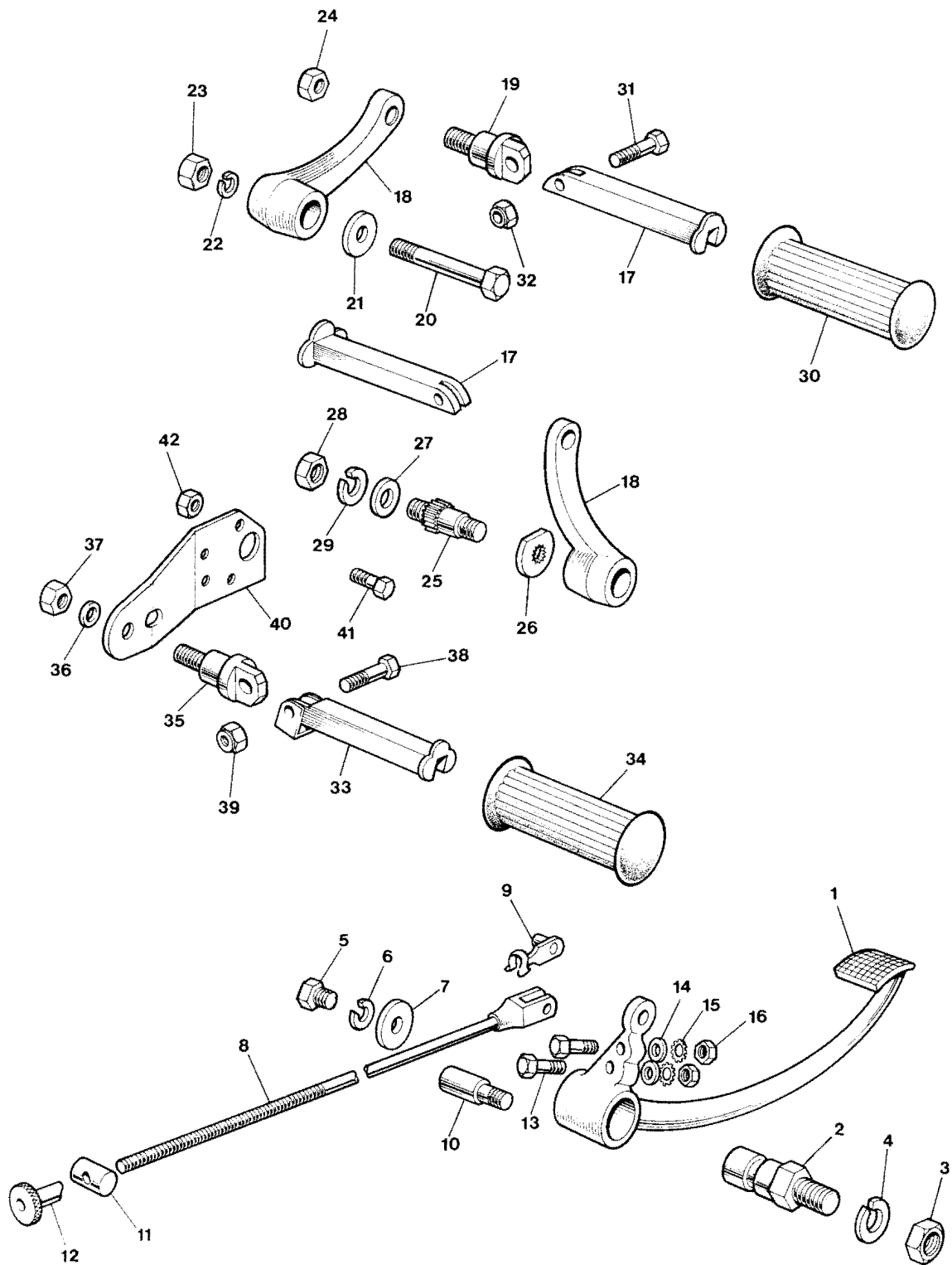

Fig. 8 FOOTRESTS AND BRAKE LINKAGE

FOOTRESTS AND BRAKE LINKAGE

1	F9031	Rear brake pedal	1
2	F9032	Fulcrum pin	1
3	F9033	Nut	1
4	F9034	Washer	1
5	E8193	Bolt ($\frac{3}{4}$ in. U.H.)	1
6	S26-1	Spring Washer	1
7	F9035	Plain washer	1
8	F9036	Rear brake rod	1
9	W2006	Toggle spring pin	1
10	F9037	Brake pedal stop	1
11	F9038	Swivel pin	1
12	F9039	Adjuster nut	1
13	F9040	Adjuster bolt	2
14	F8979	Washer	2
15	F9041	Shakeproof washer	2
16	F9042	Nut	2
17	F9043	Folding footrest	2
18	F8448	Footrest bracket	2
19	F9044	Anchor bolt	2
20	F9045	Bolt ($2\frac{1}{8}$ in. U.H.)	1
21	F9046	Plain washer	1
22	F8986	Spring washer	1
23	F8987	Nut	1
24	F9085	Nut	2
25	F9047	Stud (2 in. O.A.)	1
26	F9048	Locking plate	1
27	F9049	Washer	1
28	F9050	Nut	1
29	F9034	Spring washer	1
30	F9051	Footrest rubber	2
31	F9057	Bolt	2
32	E8137	Nut	2
33	F9053	Pillion footrest	2
34	F9054	Rubber	2
35	F9044	Anchor bolt O/S	1
35	F9055	Anchor bolt N/S	1
36	E8084	Plain washer	2
37	F9085	Nut	2
38	F9057	Bolt ($1\frac{1}{4}$ in. U.H.)	2
39	E8137	Nut	2
40	F9133	Pillion footrest support bracket O/S	1
41	F8991	Bolt	3
42	E8137	Nut	4

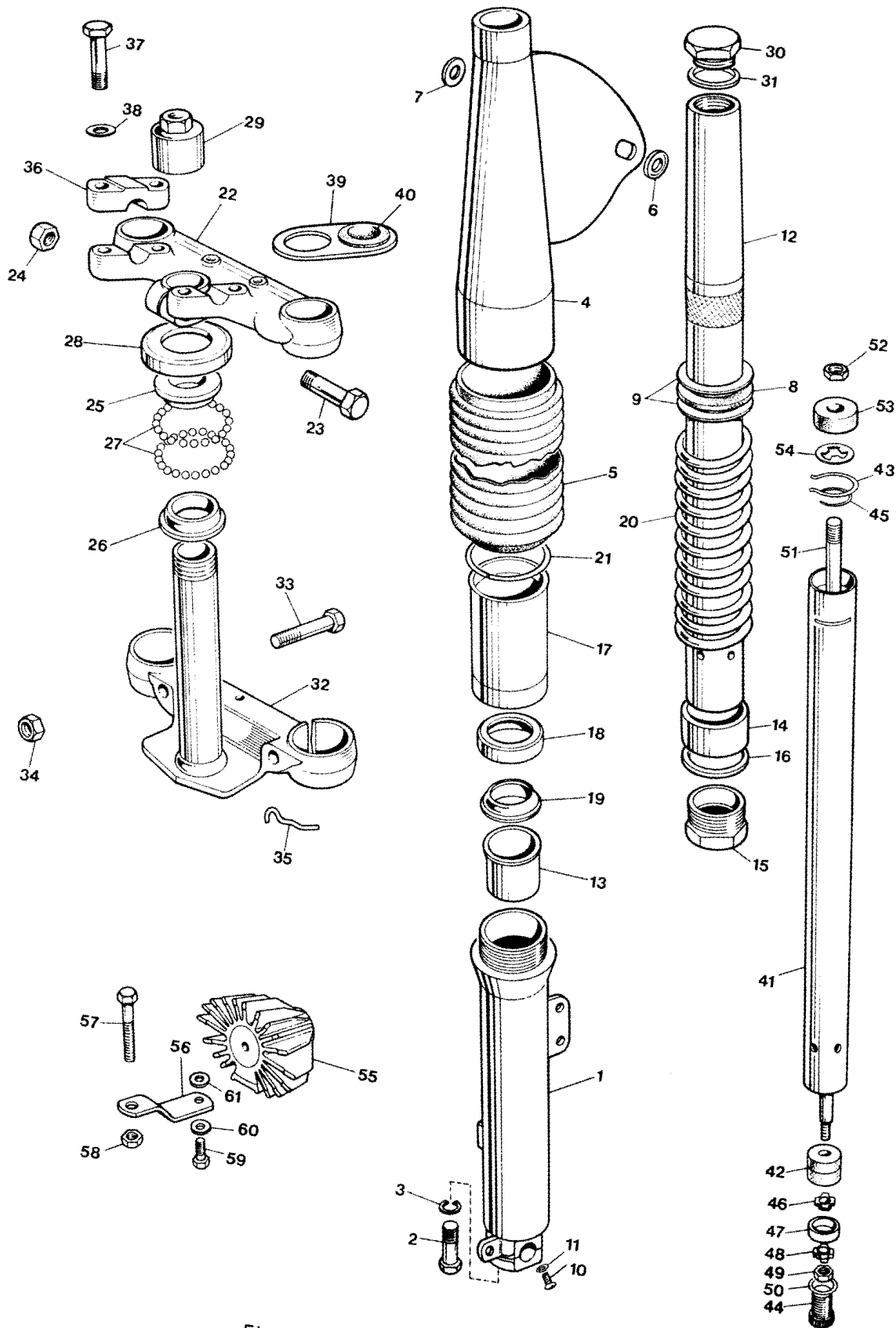

Fig. 9 TELESCOPIC FRONT FORK

FRONT FORKS

Ref. No.	Part No.	Description	Quantity
1	H3610	FORK ASSEMBLY COMPLETE	1
2	H2629	Bolt (1 $\frac{7}{8}$ in. U.H.)	4
3	F8980	Spring washer	4
4	H3652	Sleeve complete N/S	1
4	H3653	Sleeve complete O/S	1
5	H2513	Gaiter	2
6	H2630	Washer	2
7	H2631	Spacer	2
8	H2632	Sealing washer	4
9	H2633	Sealing washer	2
10	H2634	Drain plug	2
11	H2635	Fibre washer	2
12	H2636	Stanchion	2
13	H2637	Top bearing	2
14	H2638	Bottom bearing	2
15	H2639	Shaft plug	2
16	H2640	Plug washer	2
17	H2514	Oil seal holder	2
18	H2641	Oil seal	2
19	H2643	Oil seal holder and bearing spacer	2
20	H3678	Main spring	2
21	H2536	Gaiter ring	2
22	H2525	Top Lug	1
23	H2645	Bolt	1
24	H2646	Special nut	1
25	H2647	Top cone	1
26	H2648	Bottom cone	1
27	E8125	Steering head ball	40
28	H2650	Dust cap	1
29	H2651	Sleeve nut	1
30	H2652	Nut	2
31	H2653	Plain washer	2
32	H2526	Middle lug and stem	1
33	S785	Pinch bolt	2
34	14-0303	Nut	2
35	H2654	Cable guide	1
36	H2655	Handlebar clamp	2
37	H2656	Bolt	4
38	F8981	Plain washer	4
39	H2658	Cable guide bracket	2
40	H2659	Grommet	2
41	H2660	Damper Tube	2
42	H2661	Bush	2
43	H2662	Circlip	2
44	H2688	Bolt	2
45	H2664	Circlip	2
46	H2665	Valve collar	2
47	H2666	Valve	2
48	H2667	Valve seating	2
49	E8071	Nut	2
50	H2668	Washer	2
51	H2669	Damper rod	2
52	E8133	Nut	2
53	H2670	Sealing washer	2
54	H2671	Retainer	2
55	H2237	Heat sink	1
56	H3625	Bracket	1
57	14-0217	Bolt	1
58	14-0702	Nut	1
59	14-6102	Bolt	1
60	S26-12	Washer	2
61	E8088	Spacer	1

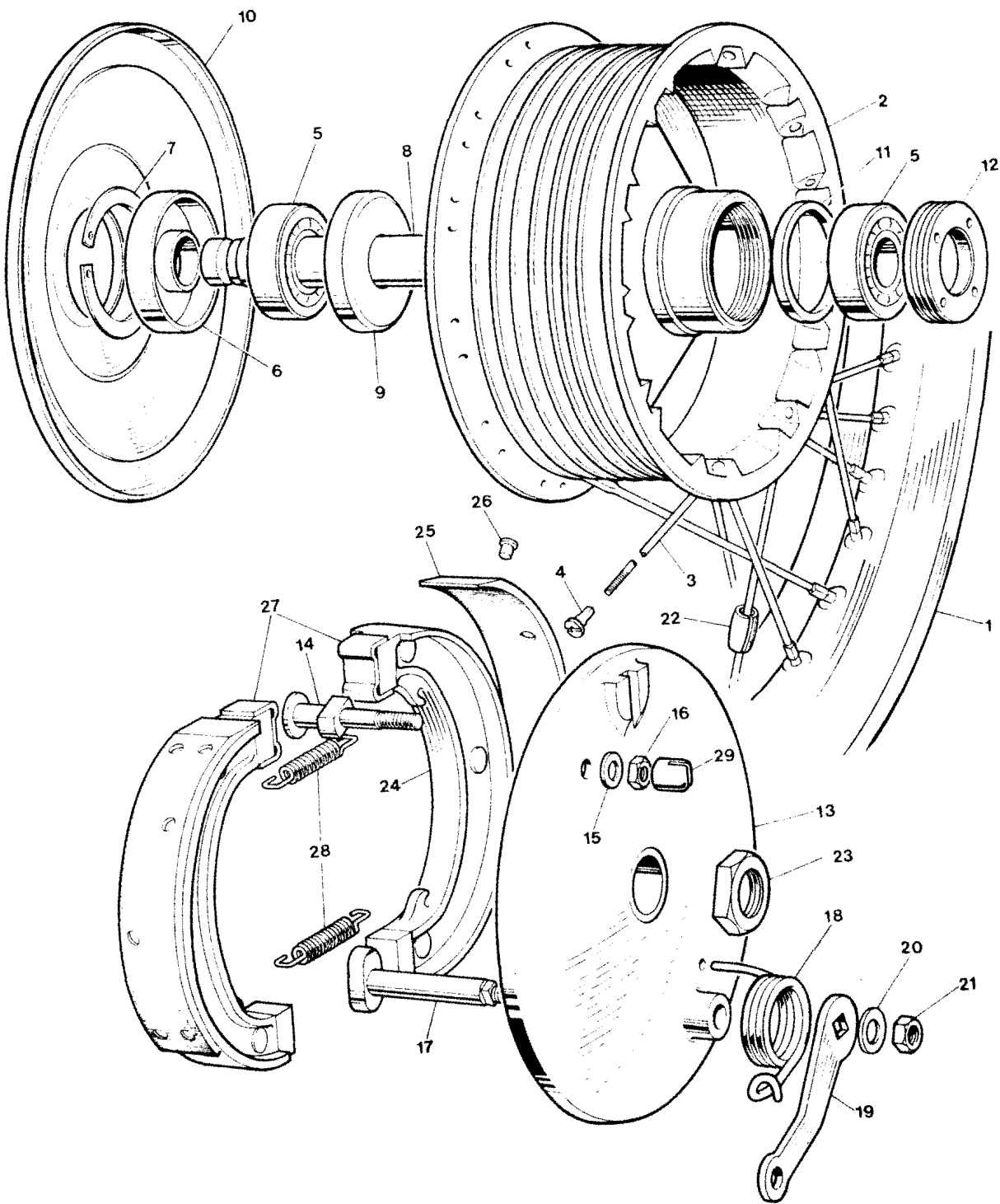

Fig.10 FRONT WHEEL

FRONT WHEEL

Ref. No.	Part No.	DESCRIPTION	QUANTITY
	W3424	FRONT WHEEL COMPLETE (LESS BRAKE AND TYRE)	1
	W3323	FRONT WHEEL RIM, HUB AND SPOKES ASSEMBLY	1
1	W1230	Rim	1
2	W3325	Hub	1
3	W1236	Spoke D/S	20
3	W3329	Spoke T/S	10
3	W330	Spoke T/S	10
4	S79-2	Nipple	40
5	W653	Bearing	2
6	W1237	Dust cover	1
7	W1238	Circlip	1
8	W1641	Spindle	1
9	W1481	Grease cap D/S	1
10	W2210	Cover plate	1
11	W3337	Bearing support ring	1
12	W582	Bearing retainer	1
13	W1301	Anchor plate	1
14	W1639	Fulcrum pin	1
15	E8084	Fulcrum pin washer	1
16	E8999	Fulcrum pin nut	1
17	W2069	Brake cam	1
18	W492	Lever return spring	1
19	W2000	Brake cam	1
20	W2027	Brake cam washer	1
21	14-0403	Brake cam nut	1
22	W1197	Balance weight short	A.R.
22	W1198	Balance weight long	A.R.
23	W1246	Spindle nut	1
	W1406	LEADING BRAKE SHOE	1
	W1407	TRAILING BRAKE SHOE	1
24	Reference only	Brake shoe	2
25	Reference only	Brake lining	2
26	Reference only	Brass rivet	16
27	W1415	Pivot pad	2
28	W135	Brake shoe spring	2
29	W1640	Cable abutment	1

Not
Serviced
Separately

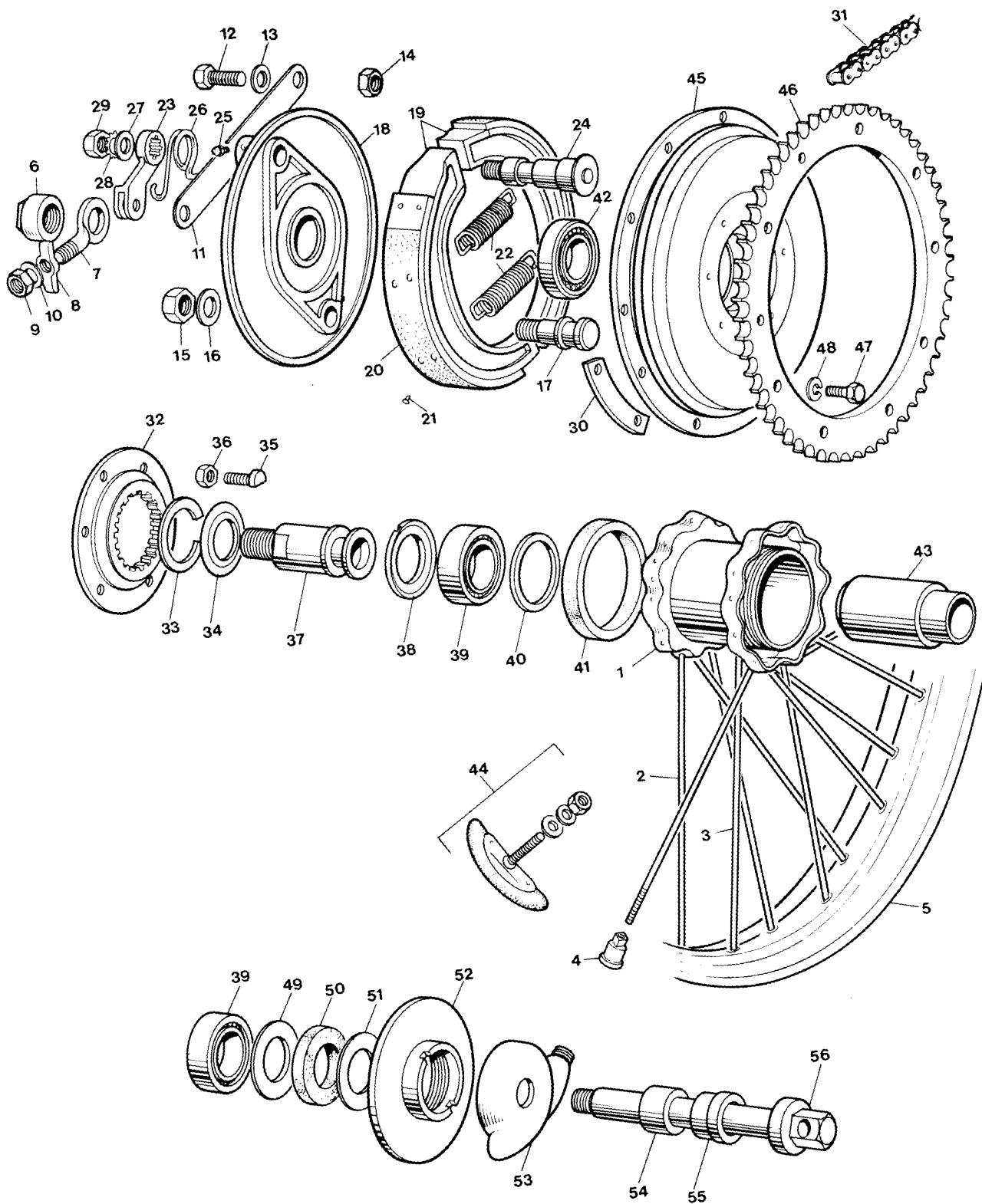

Fig.11 REAR WHEEL

REAR WHEEL

Ref. No.	Part No.	DESCRIPTION	QUANTITY
	W2289	REAR WHEEL COMPLETE (LESS BRAKE AND TYRE)	1
	W2290	RIM, HUB AND SPOKES ASSEMBLY	1
1	W2297	Hub complete	1
2	W2292	Spoke N/S	20
3	W2293	Spoke O/S	20
4	W2294	Nipple	40
5	W2291	Rim	1
6	W2309	Fixed spindle nut	1
7	W2339	Chain adjuster	2
8	W1015	Chain adjuster end cap	2
9	E8137	Adjuster nut	2
10	E8088	Adjuster washer	2
11	W2335	Torque stay	1
12	W2336	Bolt (1 $\frac{5}{16}$ in. U.H.)	1
13	W2337	Washer	1
14	F9085	Nut	1
15	W2325	Fulcrum pin nut	1
16	W2324	Fulcrum pin washer	1
17	W2323	Fulcrum pin	1
18	W2322	Brake anchor plate	1
19	W2327	BRAKE SHOE COMPLETE WITH LINING	2
20	Reference only	Brake lining	2
21	Reference only	Brass rivet	14
22	W2328	Brake shoe spring	2
23	W2329	Brake cam lever	1
24	W2226	BRAKE CAM	1
25	W2326	Grease nipple	1
26	W2334	Brake lever return spring	1
27	W2330	Plain washer	1
28	W2331	Shakeproof washer	1
29	W2332	Nut	1
30	W2317	Locking plate	3
31	D1025†	Rear Chain ($\frac{5}{8}$ x $\frac{1}{4}$ x 102L)	1
32	W2314	Driving Flange	1
33	W2312	Bearing circlip	1
34	W2311	Bearing Shim	1
35	W2315	Bolt	6
36	W2316	Nut	6
37	W2308	Fixed spindle	1
38	W2305	Bearing retainer	1
39	W2298	Bearing	2
40	W2299	Thrust washer	1
41	W2313	Washer	1
42	W2310	Bearing	1
43	W2300	Spindle sleeve	1
44	W2295	Security bolt	2
45	W2318	Brake drum	1
46	W2354*	Chainwheel (52T)	1
47	W2319	Chainwheel bolt	10
48	W2320	Spring washer	10
49	W2302	Inner retainer	1
50	W2301	Felt washer	1
51	W2303	Outer retainer	1
52	W2304	Hub end cover	1
53	D1026	Speedometer gearbox	1
54	W2306	Distance collar inner O/S	1
55	W2307	Distance collar outer O/S	1
56	W2333	Hub spindle	1

} Not Serviced
Separately

†Early editions have 99 Link chain D1023

*Early editions have 49T chainwheel 41-6091

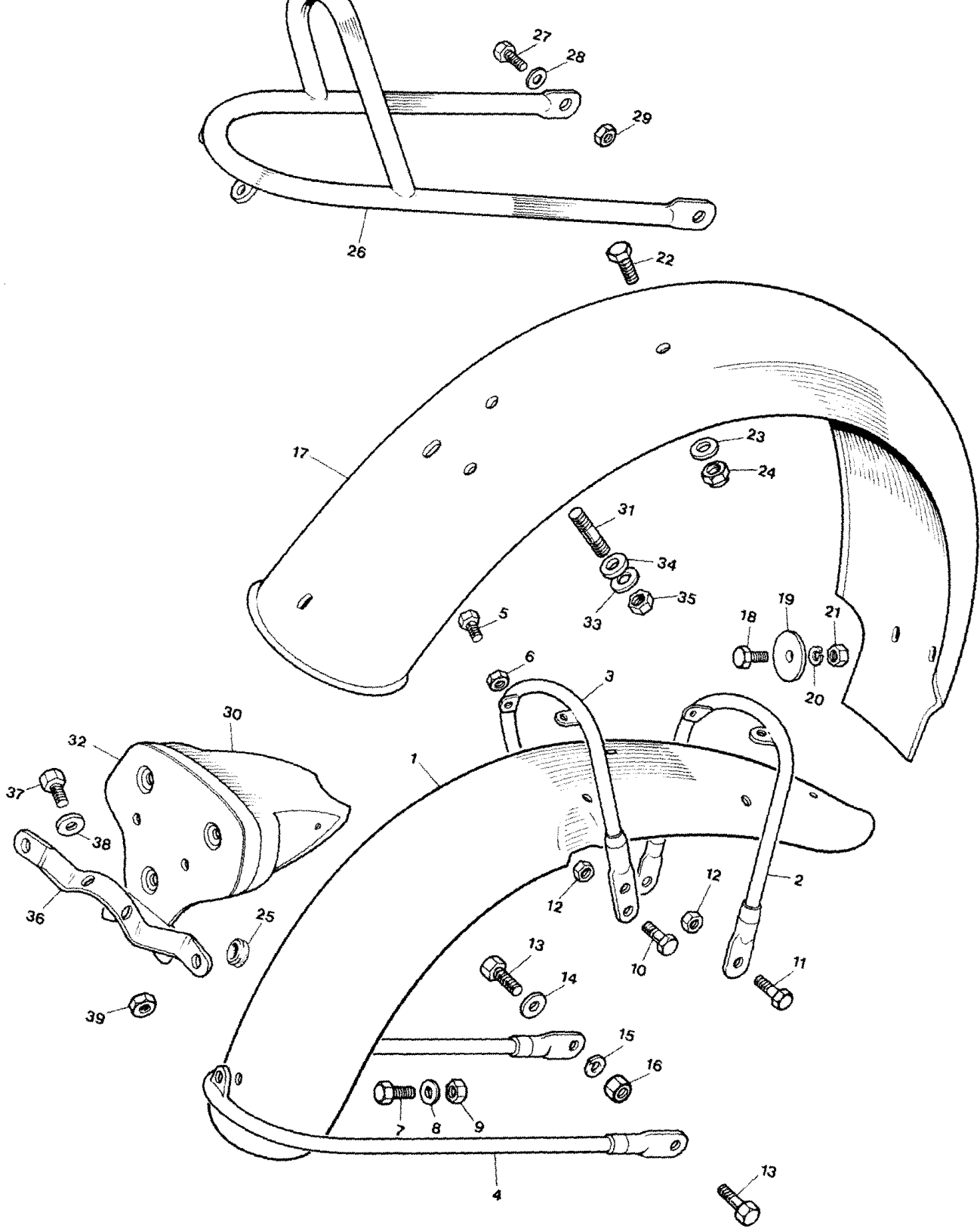

Fig.12 FENDERS

FENDERS

Ref. No.	Part No.	DESCRIPTION	QUANTITY
1	F9016	Front fender	1
2	H3619	Front stay	1
3	H3621	Bridge stay	1
4	H3623	Bottom Stay	1
5	F9019	Bolt ($\frac{1}{2}$ in. U.H.)	4
6	F9068	Nut	4
7	F9029	Bolt	1
8	E8088	Washer	1
9	W1691	Nut	1
10	F9017	Bolt ($\frac{7}{8}$ in. U.H.)	2
11	F9088	Bolt ($1\frac{1}{32}$ in. U.H.)	2
12	W1691	Nut	4
13	F8991	Bolt	2
14	E8088	Plain washer	2
15	E8134	Spring washer	2
16	F9026	Nut	2
17	F9506	Rear fender	1
18	F9019	Bolt ($\frac{1}{2}$ in. U.H.)	2
19	F9027	Special washer	2
20	F9020	Spring washer	2
21	F879	Nut	2
22	F9023	Bolt ($\frac{1}{16}$ in. U.H.)	2
23	E8088	Washer	2
24	E8137	Nut	2
25	F9028	Wiring grommet	2
26	F9481	Rear fender support rail	1
27	F9023	Bolt ($\frac{1}{16}$ in. U.H.)	2
28	E8088	Washer	2
29	W1691	Nut	2
30	F8139	Tail lamp support	1
31	E2980	Stud ($\frac{1}{8}$ in. O.A.)	1
32	F9132	Support plate	1
33	S25-1	Washer	1
34	F9030	Spacer	1
35	F9068	Nut	1
36	F9198	Rear number plate bracket	2
37	F9019	Bolt ($\frac{1}{2}$ in. U.H.)	4
38	S25-1	Washer	4
39	E8071	Nut	4

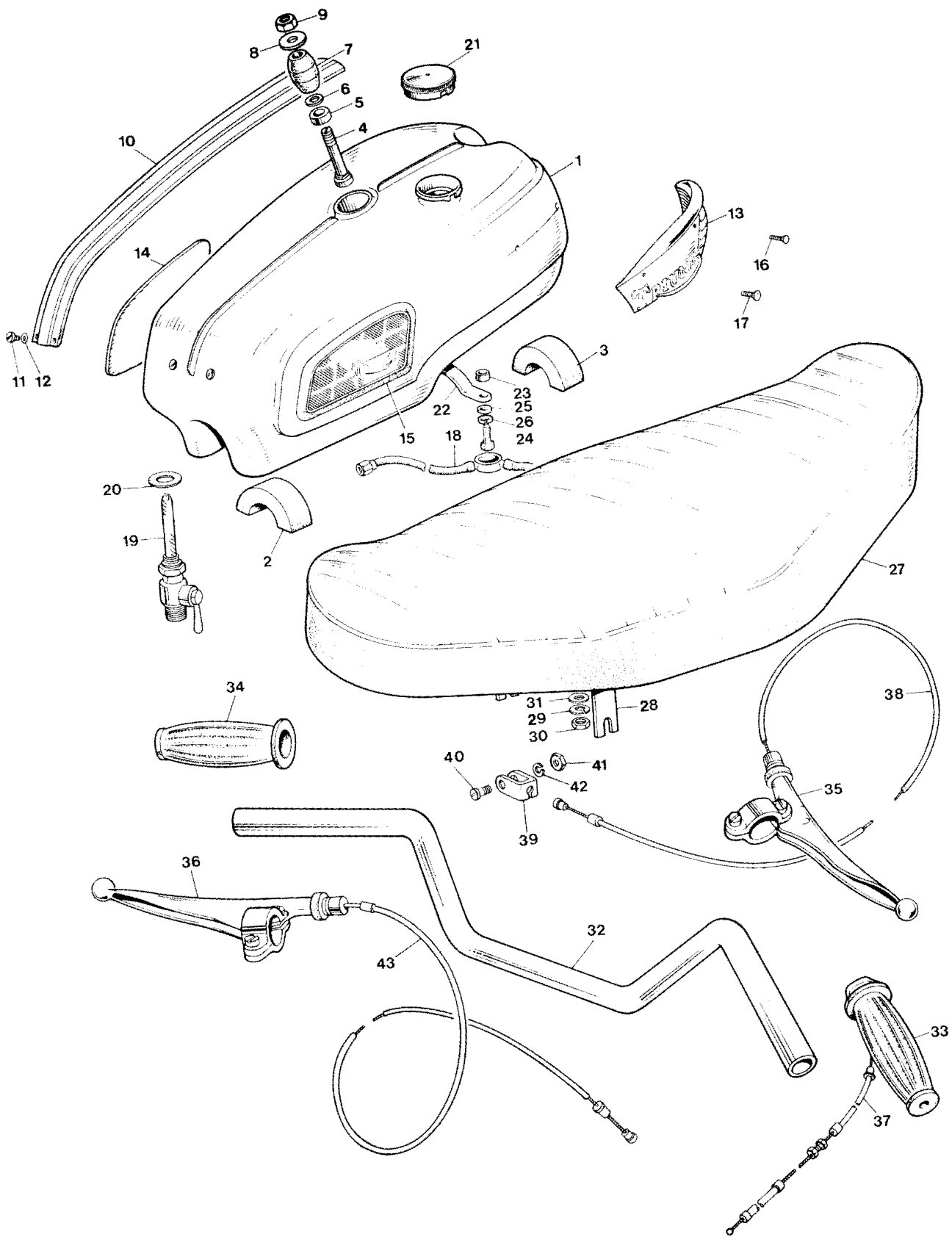

Fig.13 GAS TANK, TWIN SEAT AND HANDLEBARS

GAS TANK, TWIN SEAT AND HANDLEBARS

1	F9479	Gas tank	1
2	F9061	Mounting rubber—rear	1
3	F9134	Mounting rubber—front	1
4	S1824	Bolt	1
5	F9063	Distance tube	2
6	E8088	Plain washer	1
7	F9064	Mounting rubber	1
8	F9065	Plain washer	2
9	14-0302	Nut	1
10	F9480	Trim strip	1
11	F4715	Screw	2
12	H430	Washer	2
13	F6888	Styling unit T/S	1
13	F6887	Styling unit D/S	1
14	F8192	Knee grip D/S	1
15	F8193	Knee grip T/S	1
16	F4129	Styling unit screw—front	2
17	F7888	Styling unit screw—rear	2
18	F9769	Gas pipe	1
19	F4971	Gas tap—Short	1
19	F4972	Gas tap—long	1
20	E7351	Gas tap washer	2
21	F9226	Filler cap	1
22	F9744	Tie bar	1
23	F9196	Spacer	2
24	S5662	Bolt	2
25	E8088	Plain washer	2
26	W2320	Spring washer	2
27	F9472	Twin seat	1
28	F9476	Rear fixing bracket	1
29	F9020	Spring washer	2
30	E8101	Nut	2
31	S602	Plain washer	2
32	H2628	Handlebar—Western type	1
33	D957	Throttle twist grip	1
34	D959	Dummy grip	1
35	D960	Front brake control	1
36	D961	Clutch control	1
37	D962	Throttle cable	1
38	D862	Front brake cable	1
39	D963	Cable toggle	1
40	D964	Screw	1
41	F9020	Spring washer	1
42	D965	Nut	1
43	D966	Clutch cable	1

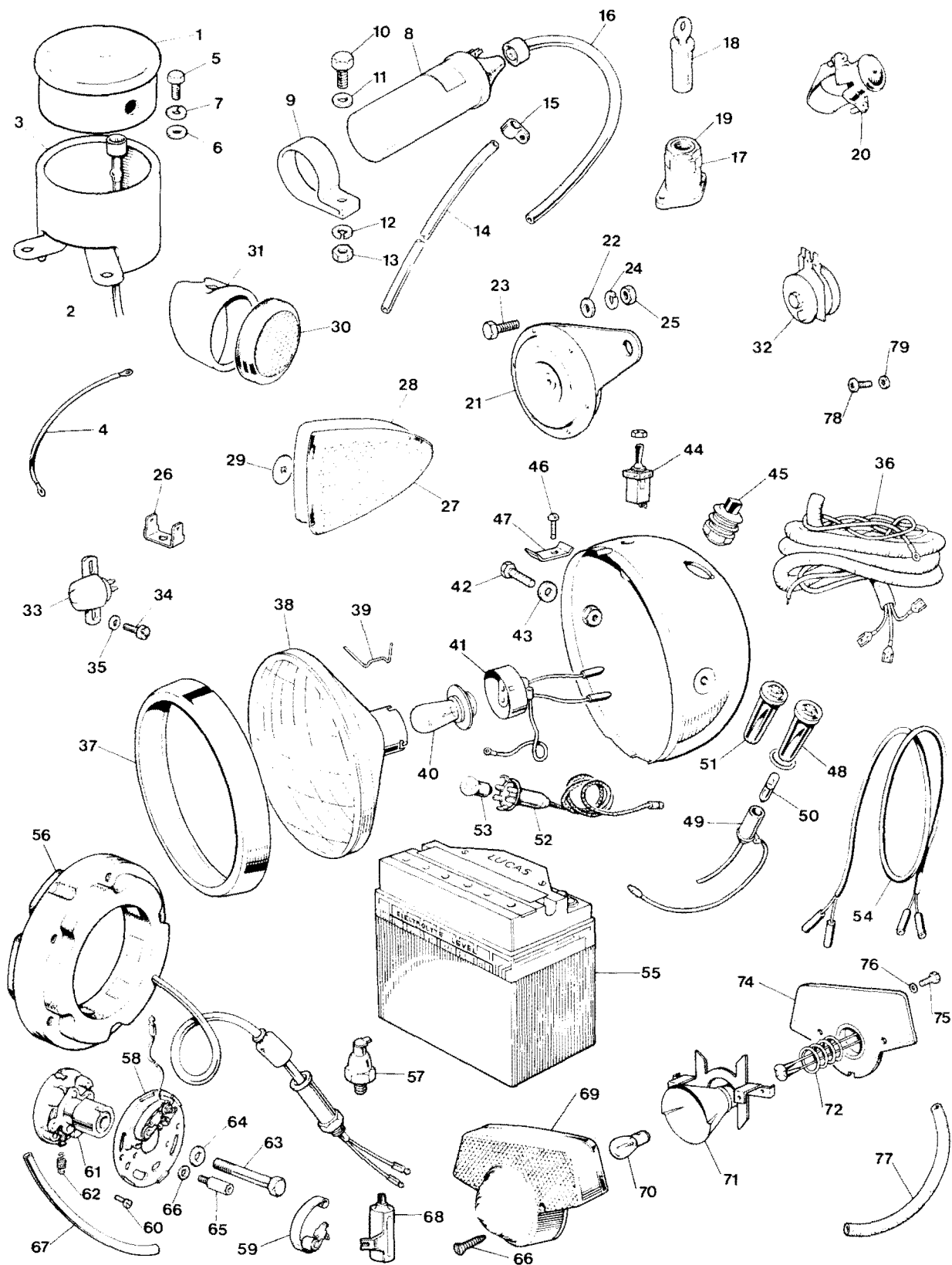

Fig.14 ELECTRICAL EQUIPMENT

ELECTRICAL EQUIPMENT

1	D1926	Speedometer head—M.P.H.	1
2	D962	Speedometer cable	1
3	H3626	Mounting cup	1
4	D1951	Speedometer lead	1
5	F9091	Bolt	2
6	E8072	Washer	2
7	E8102	Spring washer	2
8	D986	Coil (45110)	1
9	F9123	Coil support clip	1
10	F9131	Bolt ($\frac{5}{8}$ in. U.H.)	1
11	S602	Washer	1
12	F4374	Distance piece	1
13	E8071	Nut	1
14	D980	Battery vent pipe	1
15	D981	Vent pipe clip	1
16	D997	H.T. lead	1
17	D989	Ignition switch	1
18	D1000	Ignition lock	1
19	99-1000	Ignition switch nut (54130041)	1
20	D994	Horn push	1
21	D992	Horn	1
22	E8191	Washer	1
23	F5535	Bolt	1
24	E8084	Washer	1
25	E8194	Nut	1
26	D996	Double Lucar blade	1
27	F8273	Rear reflector	2
28	F8140	Rubber washer	2
29	F8195	Push-on fix	4
30	F8286	Front reflector	2
31	F8349	Reflector bracket	2
32	D1950	Rectifier	1
33	D990	Stop switch	1
34	F9191	Screw	2
35	F8979	Washer	2
36	99-1001	Harness (54953550)	1
	99-1002	HEADLAMP ASSEMBLY (59881)	1
37	99-0691	Rim (534343)	1
38	99-0688	Light unit (516828)	1
39	99-0683	Fixing wire (504665)	6
40	99-0545	Bulb (446)	1
41	99-1003	Adaptor c/w leads (54520540)	2
42	99-1004	Bolt (112201)	2
43	99-1005	Washer (137498)	2

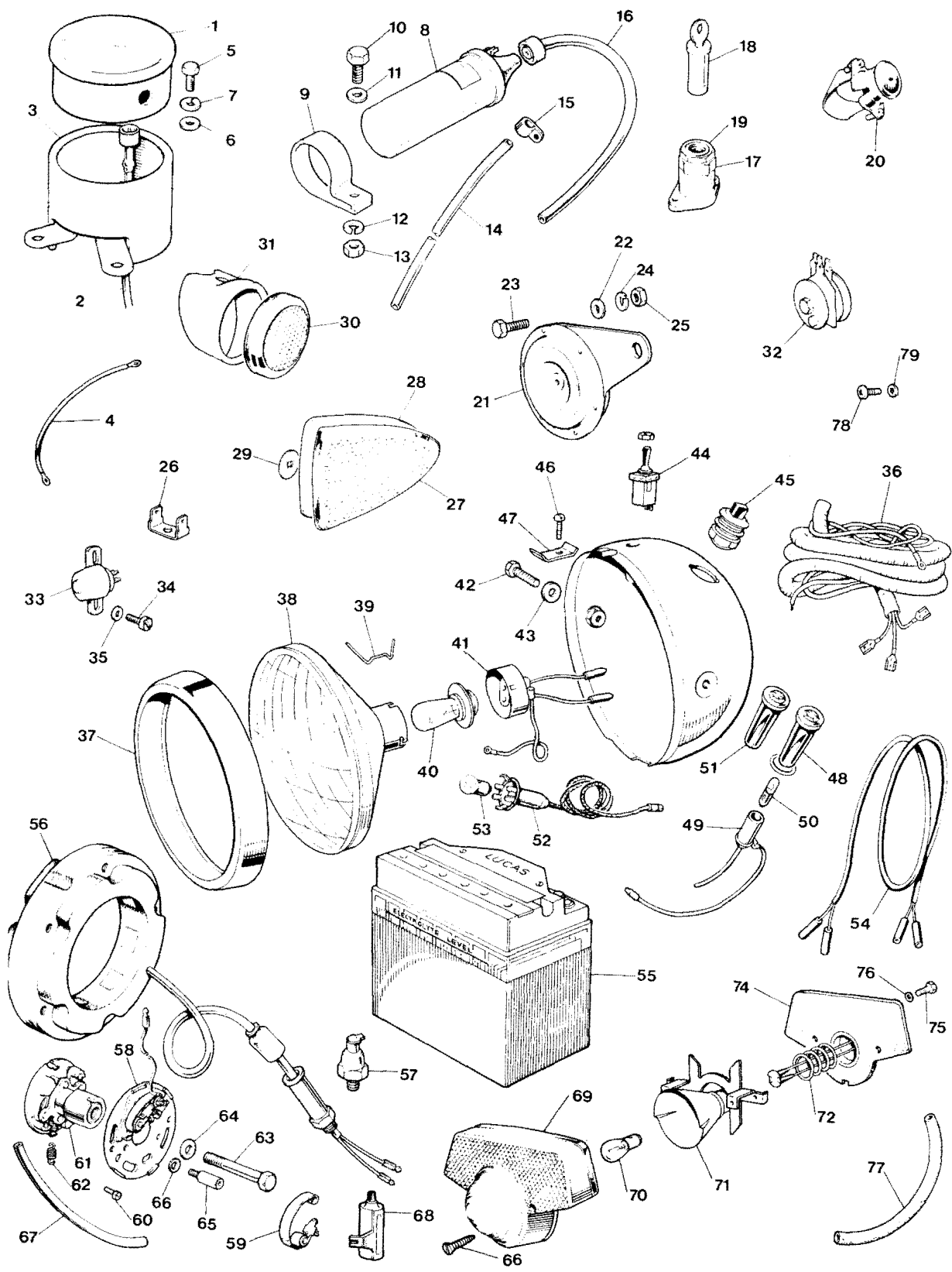

Fig.14 ELECTRICAL EQUIPMENT

ELECTRICAL EQUIPMENT

44	99-0563	Lighting switch (35710)	1
45	99-0556	Dip switch (31620)	1
46	144921	Screw	Reference only
47	55408	Plate	Reference only
48	99-0568	Warning light (Red)	1
49	54945043	Warning bulbholder	Reference only
50	99-0537	Bulb (2W BA75) (281)	2
51	99-0569	Warning light (Green) (38191)	1
52	99-0695	Pilot bulbholder (554710)	1
53	99-0548	Pilot bulb (989)	1
54	F8314	Stop-tail lead	Reference only
55	D988	Battery	1
56	99-1006	Stator (47205)	1
57	D987	Zener diode	1
58	99-1008	CONTACT BREAKER (54419645)	1
59	99-0072	Points set (54419827)	2
60	99-0769	Adjusting pin (54419220)	2
61	99-1007	AUTO ADVANCE UNIT (54419653)	1
62	99-1011	Spring set (54417992)	1
63	E7831	Contact breaker bolt	1
64	E8163	Washer	1
65	E4747	Pillar bolt	2
66	E8164	Washer	2
67	E8166	Contact breaker lead sleeve	1
68	D995	Condenser	1
	D991	STOP AND TAIL LAMP ASSEMBLY (53973)	1
69	99-0781	Lens (54572932)	1
70	99-0698	Screw (572289)	2
71	54574348	Bulbholder with reflector	Reference only
72	573828	Contact assy.	Reference only
73	99-0542	Bulb (6/21W offset pin) (380)	1
74	99-0780	Gasket (54571677)	1
75	F4715	Screw	2
76	GS299	Washer	2
77	F8307	Stop and tail lamp lead tube	1
78	F4715	Screw	2
79	GS299	Washer	2

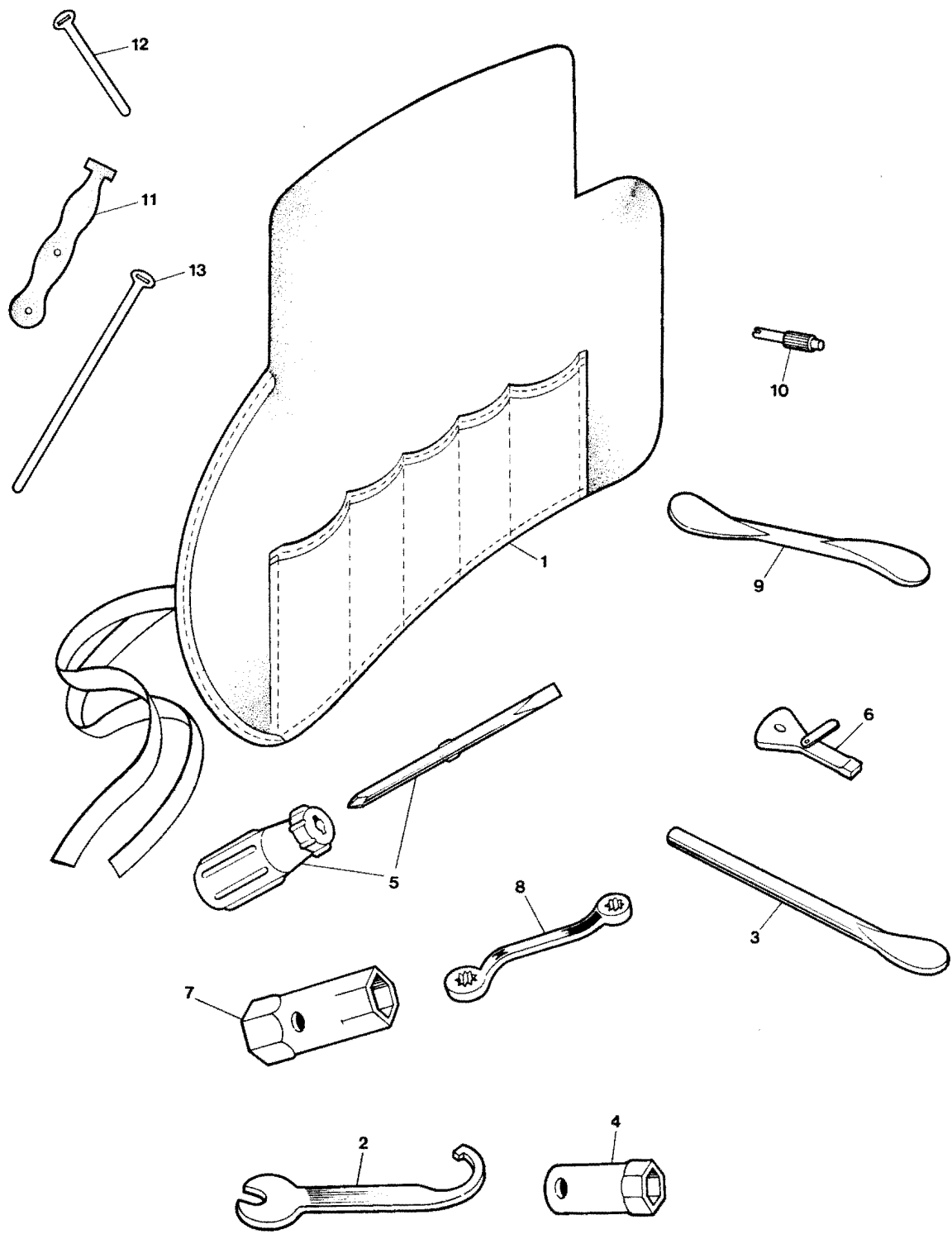

Fig.15 TOOL KIT

TOOL KIT

Ref. No.	Part No.	DESCRIPTION	QUANTITY
	D967	TOOLROLL COMPLETE WITH TOOLS	1
1	D969	Toolroll	1
2	D968	Damper unit and rear chain adjuster spanner	1
3	D801	Combined tyre lever and tommy bar	1
4	D970	Plug spanner	1
5	D767	Screwdriver set	1
6	D975	Screwdriver	1
7	D971	Box spanner	1
8	D972	Ring spanner	1
9	D973	Tyre lever	1
10	D974	Tyre valve key	1
11	D977	Rubber cable clip	9
12	D978	Alum. cable clip	4
13	XA69	Alum. cable clip	3

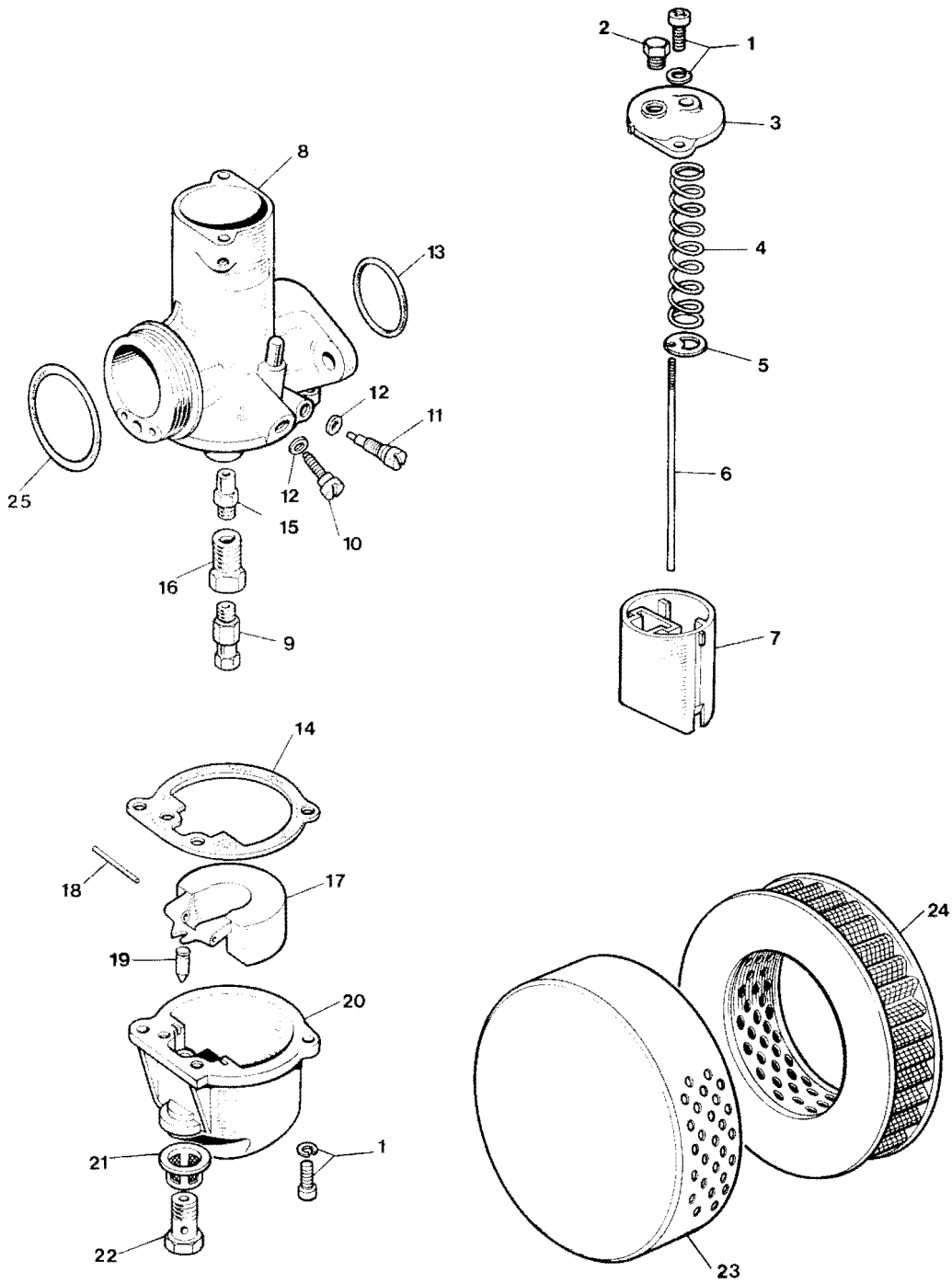

Fig.16 CARBURETTOR

CARBURETTOR

	99-0019	CARBURETTOR COMPLETE (R92814)	1
1	99-0521	Screw and washer (622-086)	4
2	99-0221	Plug screw (4-137A)	1
3	99-0531	Top cap (928-097)	1
4	99-0507	Throttle spring (622-061)	1
5	99-0510	Circlip (622-067)	1
6	99-0529	Needle (928-063)	1
7	99-0527	Throttle valve (3) (928-060)	1
8	99-1010	Body (R928/005)	1
9	376-100	Main jet (170)	1
10	99-0516	Throttle stop screw (622-077)	1
11	99-0515	Pilot air screw (622-076)	1
12	99-0520	'O'-ring (622-082)	2
13	99-0522	'O' ring (622-101)	1
14	622-073	Gasket	1
15	99-0518	Needle jet (.106) (99-0518)	1
16	99-0519	Jet holder (622-080)	1
17	99-0512	Float (622-069)	1
18	99-0513	Float spindle (622-071)	1
19	99-0511	Float needle (622-068)	1
20	99-0506	Float chamber (622-050)	1
21	376-093	Filter	1
22	99-0517	Banjo bolt (622-078)	1
23	F9000	AIR CLEANER COMPLETE	1
24	F9194	Air cleaner element	1
25	F9001	'O' ring	1