

MOTOR CYCLE ALTERNATORS | SERVICE MANUAL

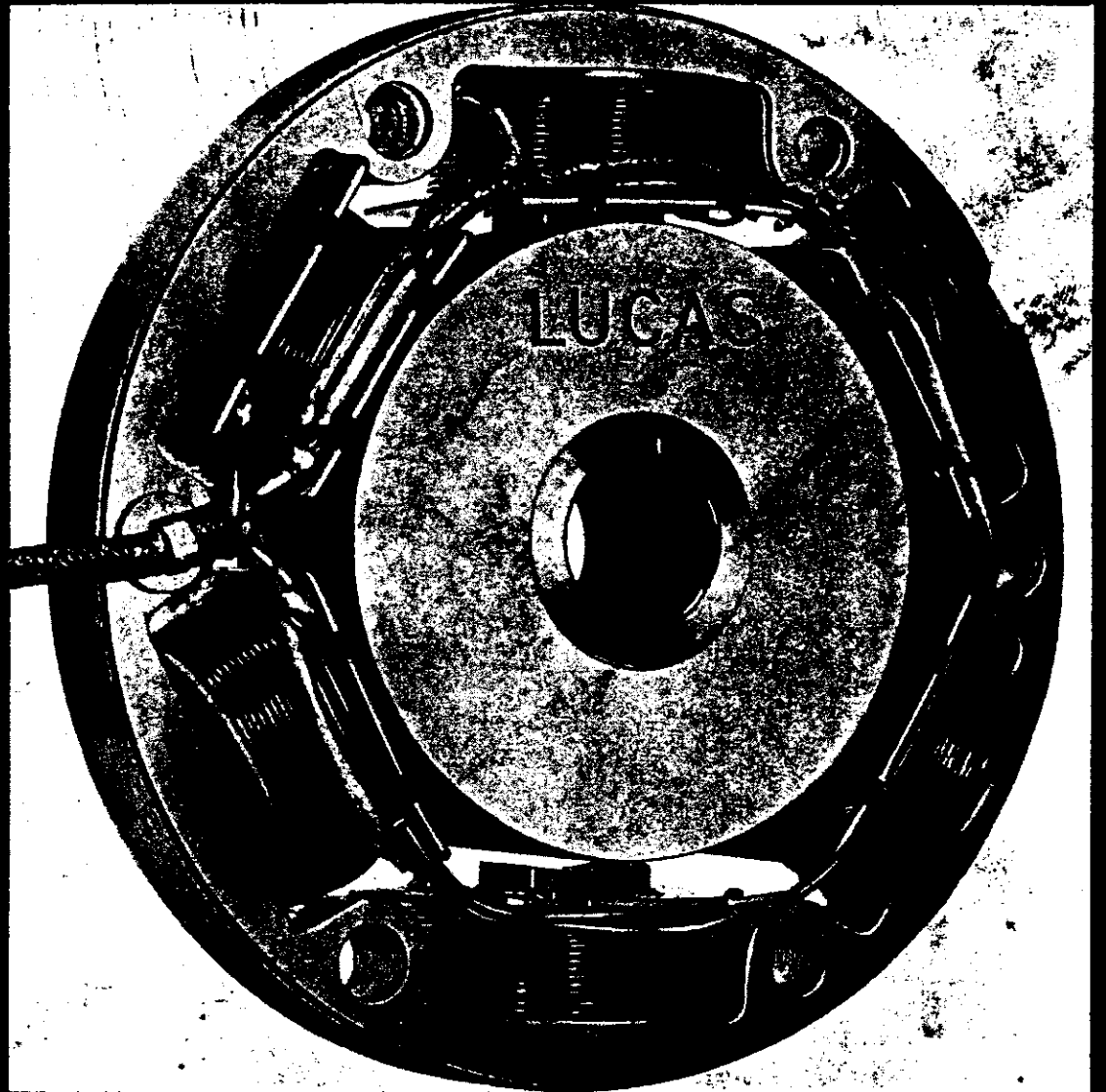

Kim The CD Mark 2103

LUCAS

Alternating - Current

GENERATORS

for

MOTOR-CYCLES

WORKING PRINCIPLES AND SERVICE TESTING PROCEDURES



JOSEPH LUCAS (SALES & SERVICE) LTD · BIRMINGHAM 18



INTRODUCTION

Since this publication was first introduced in 1954 LUCAS A.C. equipment has become the standard fitment on the majority of British motor cycles. It is also fitted as standard equipment on several British scooters.

Alternating current equipment is now being supplied for 6-volt and 12-volt applications. The 12-volt equipment applications on the larger capacity machines usually incorporates Zener Diode charging control. On scooters 12-volt equipment is usually fitted to machines which incorporate an electric starting motor as a "de-luxe" feature.

In recent years there has been considerable standardization of the A.C. equipment as fitted to the normal type of road machine, these form the majority of present-day production. However, several special alternators and output control systems have been introduced to cater for racing and competition machines; and for machines which are subjected to abnormal running or service conditions. This second edition of SB519 contains instructions for testing all of these systems, which you are likely to meet in service.

No undue difficulty should be experienced when servicing A.C. equipment. In fact, our service experience to date confirms our earlier views that even the fitter or mechanic who is not normally concerned with "electrics", can become quite proficient at fault location, provided he has some basic understanding of the operation and make-up of the A.C. generator and its associated equipment.

Until fully conversant with motor cycle A.C. equipment we recommend you to follow the test procedures in the sequence in which they are given, to avoid delay in diagnosing faults. As one becomes more familiar with the principles, "short cuts" in the testing procedure can then be made with confidence.

Last, but not least, a word about test equipment. We have pre-supposed that good quality test equipment will be available, for without it, it will not be possible to carry out tests with any accuracy. For efficient servicing, quality instruments of the type we have recommended should be obtained.

©

COPYRIGHT

*All rights reserved. No part of this
publication may be reproduced
without permission.*

JOSEPH LUCAS (SALES & SERVICE) LTD., BIRMINGHAM, 18, ENGLAND.

CONTENTS

	<i>Page</i>
INTRODUCTION	2
PART 1 — The Lucas Range of Alternators	5- 7
General Description	5- 6
Functions	6- 7
Maintenance	7
 PART 2 — Working Principles	 8-19
How an E.M.F. is produced	8
A simple A.C. Generator	8
The sine wave	9
Rectification	9-10
Controlling the alternator output	10-12
Emergency starting	12-15
Timing for emergency ignition	15
A.C. ignition	16-17
Zener Diode charge control	17-18
Clipper Diode voltage stabiliser	18-19
 PART 3 — General Servicing Information	
Increased charging rates for 6-volt equipped machines	20
Ignition warning devices	20
Wiring modifications when converting from coil to magneto ignition	20
Fitting a Lucar service connector	21
Connections for trials or competition purposes	21
Securing a Silicon Diode Rectifier	22
PRS8 switch connections	22
Methods of adjusting daytime charge-rate on Radio-equipped machines	23-27
Conversion of 6-volt machines to 12-volt Zener Diode charge control	28-31
RM12 — converting Series "B" machines to Series "C"	32-33
Test equipment required	33-34
Switch Continuity Tests	34
Instructions for Fitting and Wiring-up Clipper Diode	34

(Continued)

CONTENTS (Continued)

	<i>Page</i>
PART 4 — Test Procedure for IA45 Set	35-39
Checking D.C. input to the battery	36
Testing the IA45 alternator	37
Rectifier bench testing	38
Circuit continuity through switch positions	39
 PART 5 — Test Procedure for RM12 Set	 41-46
Checking D.C. input to battery	42
Testing the RM12 alternator	43
Rectifier bench testing	44
Checking the external wiring circuit	45
Testing switch circuit continuity	46
 PART 6 — Test Procedure for RM13 — RM13/15 — RM14 — RM15 — RM18 — RM19 — RM20/19 — 9AF — 5AF — 6 and 12-volt Alternator Sets	 47-56
Checking the rectifier D.C. current output	48-49
Testing the alternator	50-51
Checking the rectifier on the machine	52
Rectifier bench testing	53
Checking the Zener Diode on the machine	54
Testing the 2ET and 3ET ignition coils	55
Checking circuit continuity	56
 PART 7 — Location and Remedy of Faults	 57-58
Ignition circuit (A.C. — Magneto and Coil)	57
Charging circuit	58
Lighting circuit	58
 PART 8 — Selection of Circuit and Wiring Diagrams	 60-85
IA45 on B.S.A. "Bantam" — Brockhouse — Dot — O.E.C.	60-61
RM12 Series "A" on Triumph 5 T.A.C.	62-63
RM12 Series "C" on Triumph 5 T.A.C.	64-65
RM13 on B.S.A. — Triumph "Terrier" and "Cub"	66-67
RM14 on Triumph 5 T.A.C. and 6 T.A.C.	68-69
RM13 on Brockhouse — Enfield or any single cylinder machine	70-71
RM14 — Lighting-Ignition switch circuit for twin cylinder machines	72
RM13 or RM14 — Circuit for single and twin cylinder magneto machines	73
Typical two charge-rate control systems for twins	74
Arrangement of connections for 63SA and 88SA switches	75
Typical A.C. ignition direct lighting system	76
Typical zener diode, twin-coil, twin contact-breaker system	77
Typical three charge-rate control system for twins	78
Typical three charge-rate control system for singles	79
Typical 12-volt two charge-rate control for twin coil and starter system	80
Typical system with maximum charge ("booster") switch	81
Twin cylinder A.C. ignition — no lights	82
Single cylinder A.C. ignition — direct lighting	83
Circuit showing alternator permanently connected for full output — with zener diode charge control	84
Twin A.C. ignition, twin contact-breakers and full direct lighting	85

TEST DATA CARD IN REAR COVER POCKET.

General Description of the Lucas Range of Alternators and their Functions in Service

ALTERNATOR MODELS Old Range (RM13 - 14 - 15 - 5AF)

Motor cycle alternators comprise a six-pole permanent magnet rotor and a six-limbed laminated iron stator. The rotor is driven by an extension of the engine crankshaft while the stator is located in the crankcase or chain case. The rotor has an hexagonal steel centre, each face of which carries a high-energy magnet keyed to a laminated pole tip, as shown in Fig. 1. The six pole tips are riveted to brass end plates. This assembly is cast in aluminium and then machined to give a smooth external finish. Five-inch diameter stators, of differing thicknesses, have been used for all models except RM14, for which thick, intermediate and thin hexagonal stator packs of 5 7/8" A/F (5 3/8" spigot dia.) were used.

Two rotor lengths are used. Alternator, model RM13/15 utilises the RM13 stator pack with the longer rotor as fitted in model RM15, in order to obtain output characteristics intermediate between these two.

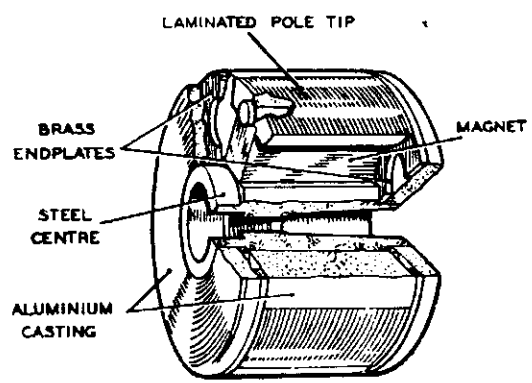

Fig. 1 View of rotor, sectioned

The same rotor and stator sizes are used in model 5AF (Fig. 2) scooter alternator but, in this case, the rotor is cast integral with the engine flywheel and cooling fins. This flywheel, when fitted to 6-volt units, carries an inertia ring while, in 12-volt units, a ring gear is fitted for engagement with the starting motor, model M3.

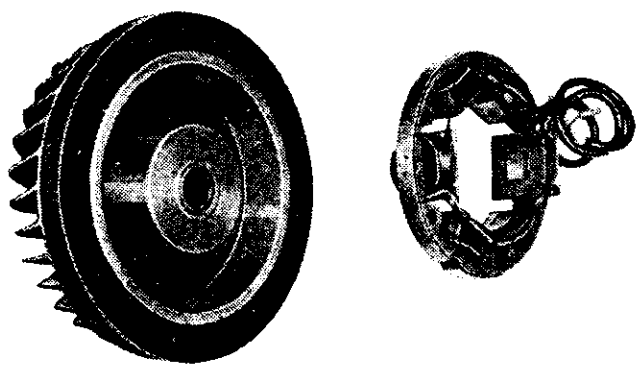

Fig. 2 Alternator model 5AF, stator and flywheel assembly

Models RM14 and RM15 (Figs. 3 and 4) are fitted to large capacity machines having high top gear ratios while the remainder are fitted to small capacity machines having low top gear ratios.

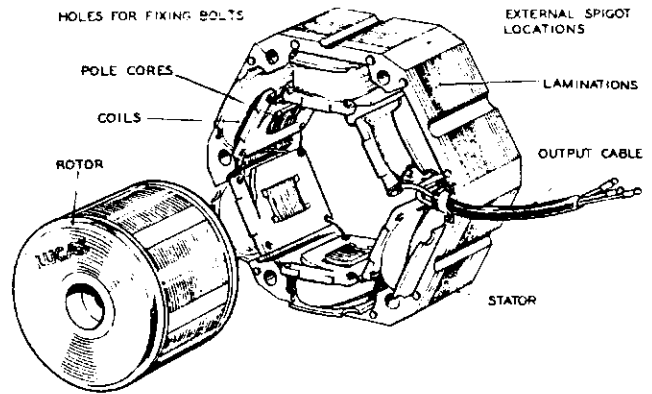

Fig. 3 Alternator model RM14, with rotor withdrawn

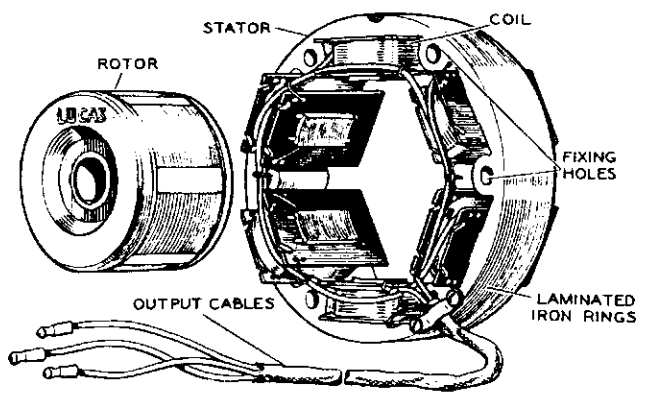

Fig. 4 Alternator model RM15, with rotor withdrawn

New Range (RM18 - 19 - 20/19)

Models RM18, 19 and 20/19 comprise a new range of alternators superseding models RM13, 13/15, 15. The new alternators differ from each other in thickness (the rotors of RM18, RM19 and RM20/19 containing approximately 25, 32 and 45 iron laminations, respectively, with the associated stators having approximately 14, 16 and 26), and from the previous range in respect of rotor diameter—the latter now being 0.165" (4.2 mm.) greater in diameter and able to accept driving shafts of up to one inch (25.4 mm.) in diameter.

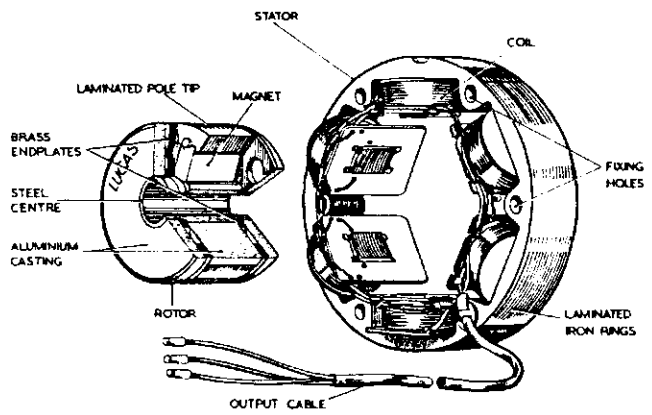

Fig. 5 Alternator model RM18

Model RM18 supersedes RM13 and is normally fitted to small capacity machines having low top gear ratios, whilst RM19, superseding RM13/15 and 15, is for larger

General Description of the Lucas Range of Alternators and their functions in Service

machines. Model RM20/19 is to accommodate additional current consuming equipment, such as two-way radio, fitted to special purpose machines – particularly as used by military forces and road patrols of the Police, Automobile Association and Royal Automobile Club. Other versions of the new range include units wound to provide A.C. ignition, with or without the direct lighting of head, tail and stop lamps.

Rotors of the new range are straight-sided like those of former models RM12 and 14 but can be distinguished from them by being 0.414" (10.5 mm.) smaller in diameter. The steel centre of models RM13 and 15, on the other hand, were recessed on the side that carried the Company's name. See Fig. 6.

The new stators, while carrying the usual coil cheek retaining tags, also exhibit a small tongue at the side of each pole core. See Fig. 7.

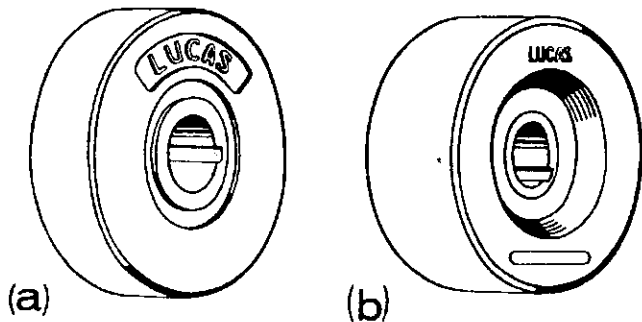

Fig. 6 Alternator rotors (a) new type (b) old type

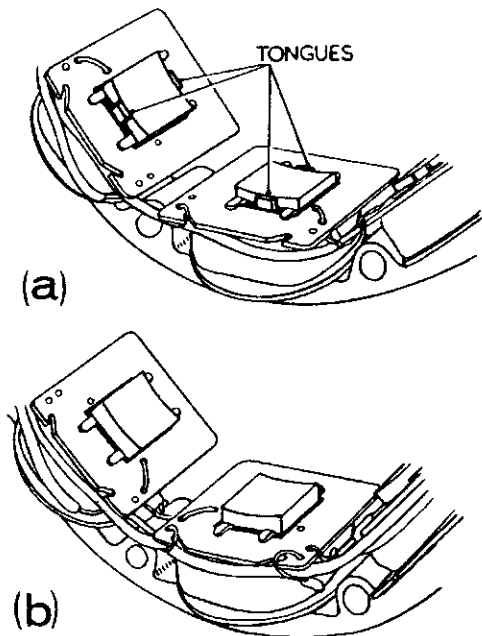

Fig. 7 Alternator stators (a) new type (b) old type

Function

Today, motor cycle alternators are designed, either, to provide battery charging through a full-wave bridge-connected rectifier, in conjunction with magneto or coil ignition – when (with coil ignition) provision is also made for emergency starting in the event of a flat battery and even for restricted running without a battery – or to

provide an A.C. energy transfer ignition system with direct lighting.

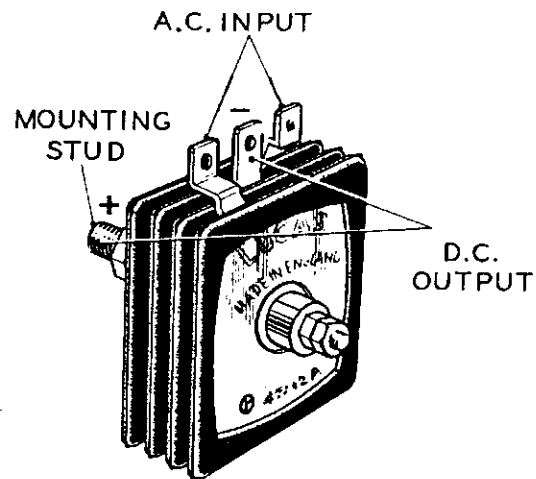

Fig. 8a Selenium metal plate rectifier (new type)

Alternators and battery D.C. lighting, with magneto or D.C. coil ignition, are normally specified for Roadsters, while alternators for direct A.C. lighting and A.C. energy transfer ignition are normally specified for Competition machines. A few alternator equipped machines were made in which both battery lighting and energy transfer ignition were combined. However, this practice was discontinued due, mainly, to the problem that the then existing sizes of alternators presented of providing adequate ignition timing ranges with ample capacity for battery charging.

Two typical motor cycle rectifiers are shown in Figs. 8(a) and 8(b).

Alternators for Battery Charging

When no lights are in use, the rectified output of the alternator is sufficient only to supply the ignition coil and to trickle charge the battery. On turning the lighting switch, the output is automatically increased to meet the additional load. On some machines (usually those fitted with magneto ignition) an increase occurs both when the parking light is switched on and again when the main bulb is brought into use. On other machines (usually of low capacity and with coil ignition, or with low speeds engines and heavy electrical loading) an increase occurs only when the main bulb is switched on. Details of the alternative circuits involved are given in the section on "Working Principles".

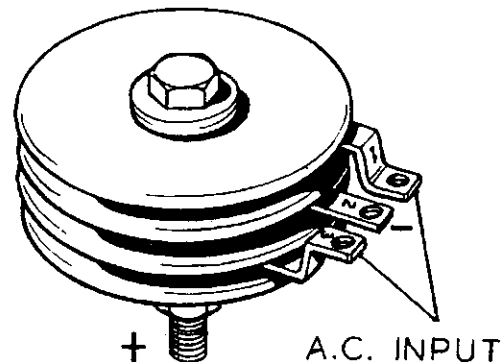

Fig. 8b Selenium metal plate rectifier (old type)

General Description of the Lucas Range of Alternators and their Functions in Service

Alternators for A.C. Ignition

Alternator models for A.C. ignition are used, together with a contact breaker unit and a special energy transfer ignition coil, model 2ET or 3ET – the four-limb stator winding of the alternator and the ignition coil primary winding being electrically matched. The alternator supplies a pulse of energy to the ignition coil primary winding each time the contact breaker contacts open. These low tension pulses are converted by the ignition coil to the high tension voltages required at the sparking plug. This form of ignition combines the good top speed characteristics of the magneto with the good low speed performance of the conventional ignition coil.

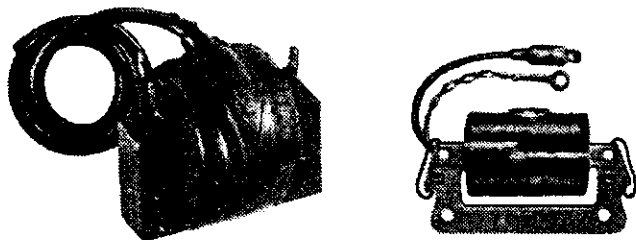

Fig. 9 Model 2ET coil (left) and model 3ET coil (right)

The remaining stator limbs are wound to provide alternating current for a direct lighting set, or rectified current for battery charging. Stop-lights are fed, either, from two coils of a four-coil ignition winding or from independent coils.

ROUTINE MAINTENANCE Alternator

The alternator, having no rotating windings, commutator, brushgear, bearings or oil seals, requires no maintenance, apart from an occasional check of the snap-connectors in the three output cables to ensure that these are clean and secure.

To obviate metal contamination of the rotor, stator and windings, the chain case oil should be changed as regularly as is recommended by the motor cycle manufacturer. This procedure is particularly important if the stator carries ignition windings.

If removal of the rotor becomes necessary for any reason, there will be no necessity to fit magnet keepers to the rotor poles. On removing a rotor, wipe off any metal swarf that may have been attracted to the pole tips and put the rotor in a clean place.

Rectifiers

Selenium plate types: These rectifiers require no maintenance, apart from an occasional check of the cables and the securing nut.

The nuts that clamp the rectifier plates together must never under any circumstances be turned, the clamping pressure having been carefully set during manufacture to give the correct rectifier characteristics.

When tightening rectifier fixing nuts, the plate assembly must never be gripped by hand in an attempt to prevent turning. Instead, two spanners must always be used – one being applied to the fixing nut and the other to the hexagonal part of the mounting stud or, in earlier types, to the backing nut.

The 2BA nuts shown in Fig. 8(a) must never be disturbed.

Silicon Diode Types: These rectifiers do not require any maintenance and, provided they are mounted in such a position as to allow plenty of cool air to flow between the plates on which the diodes are attached; these circular plates are in effect a heat-sink, they will give a long trouble-free service life.

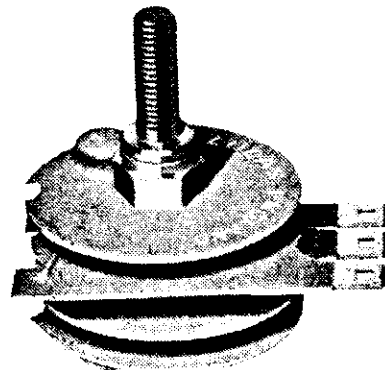

Fig. 10 Silicon diode rectifier with Lucas terminals

Zener Diode – Battery Charge Current Controller (when fitted): As with the silicon rectifiers, the main thing is to see that the mounting plate or heat-sink is positioned so that it has plenty of cool air flowing across it. It should also be kept as clean and as dry as possible. No other maintenance is required.

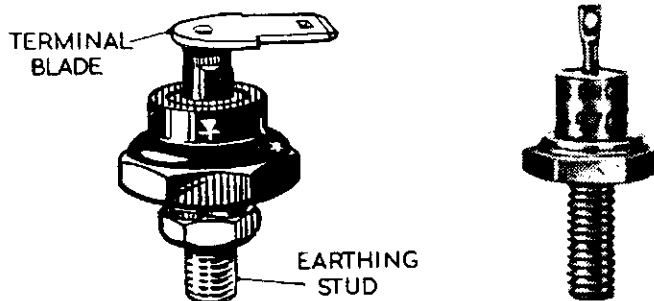

Fig. 11a (left) Zener Diode, model ZD715 (part no. 49345)
Fig. 11b (right) Clipper diode, model CD4008

Clipper Diode – Voltage Stabiliser

The same maintenance instructions given for the Zener Diode apply to the Clipper Diode. Provided it is mounted on a suitable heat-sink, in a good flow of cool air, it only requires to be kept clean and dry in order to give a long trouble-free service life.

Like most semi-conductor devices, the Clipper Diode is heat sensitive and has a maximum working temperature which must not be exceeded. In this case, 239°F. (115°C.) is the safe upper limit. This means that the Diode must be mounted on an aluminium or copper plate which will act as a heat-sink. The heat-sink, to be effective, must be $\frac{1}{16}$ " (1.59 mm.) thick, while the plate area will depend on the maximum output of the alternator as follows:—

- Up to 21 watts: 2" x 3" (50.8 x 76.2 mm.).
- Up to 25 watts: 3" x 3" (76.2 x 76.2 mm.).
- Up to 30 watts: 3" x 4" (76.2 x 101.6 mm.).

Care should be taken to see that the mounting stud is not overtightened when bolting to the heat-sink. The Clipper Diode should not be used with alternators having outputs greater than 30 watts.

Working Principles

HOW AN E.M.F. IS PRODUCED

When a conductor is moved through a magnetic field an electro-motive force or E.M.F. is induced into it. If the conductor forms a loop or closed circuit, an electric current will register on a sensitive meter connected across the conductor. When the conductor is moved downwards, as shown in the illustration Fig. 12a, the needle swings in a direction corresponding to the direction of current flow.

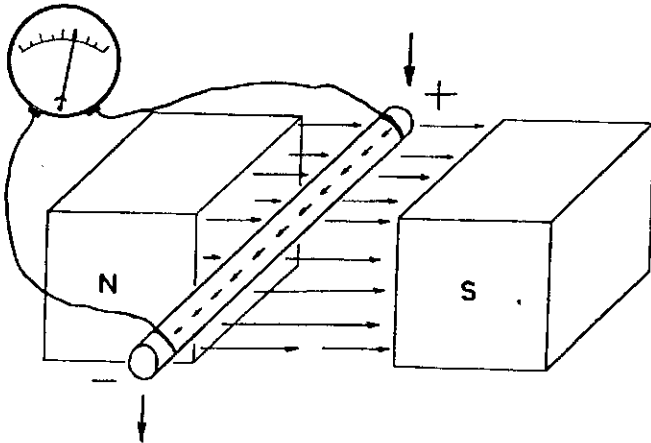

Fig. 12a

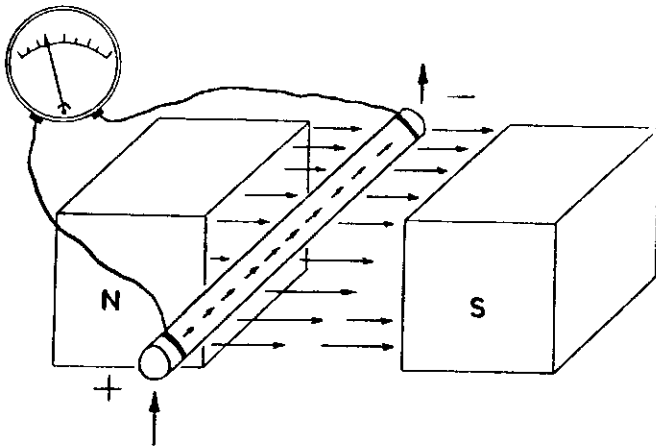

Fig. 12b

If the conductor is moved upwards, Fig. 12b, the needle will swing in the opposite direction, indicating that the current flow is also in the opposite direction.

The amount of movement of the needle will depend upon the speed at which the conductor is moved up and down, and the density of the magnetic field. The same effect can be obtained by moving a magnet in and out of a coil of wire, Fig. 13.

Induction will again take place and current flows in the wire coil. This time, because the coil consists of several turns of wire, instead of one single conductor, the induction will be increased, thereby giving a greater output. The sensitive meter, if connected across the ends of the coil, will register in exactly the same manner as it did with the single conductor.

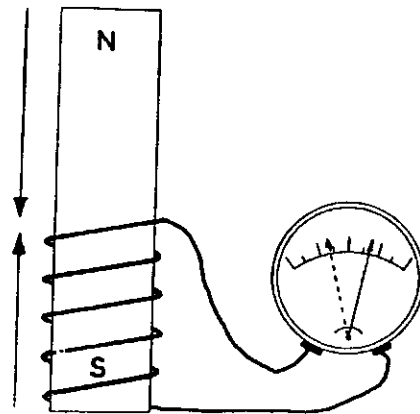

Fig. 13

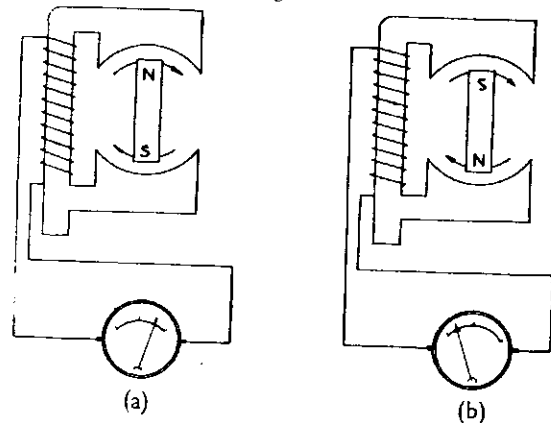

Fig. 14

A SIMPLE A.C. GENERATOR

Figure 14 shows an A.C. generator in its simplest form. The coil has now been wound round a piece of iron which forms a yoke. The yoke helps to concentrate the magnetic field around the coil. In the centre of the yoke a bar magnet is made to rotate.

The direction of the magnetic field will change every 180° of rotation of the magnet. In the left hand illustration the north pole is at the top, but after the magnet has rotated 180° , the south pole is at the top. The magnetic field has been reversed. The direction of current flow in the coil has also been reversed. Induction has taken place due to movement of the magnet in close proximity to the coil, and alternating current has been produced.

Exactly the same thing happens on a larger scale, with the LUCAS range of single-phase A.C. generators. The current generated in the coils is used for lighting, and ignition purposes, etc.

The principle of operation of the early LUCAS inductor type generator is the same as that of the present day rotating magnet type, the difference being in the method used to achieve this.

In the inductor generator (IA45) the coils and magnets are stationary and a six-pole, laminated steel rotor, fixed to the engine crankshaft, is used to cause the flux reversals (Fig. 15a).

The RM range of generators uses a magnetic six-pole rotor to cause the flux reversals, Fig. 15b, the coils are stationary, being fixed to the stator assembly.

Working Principles

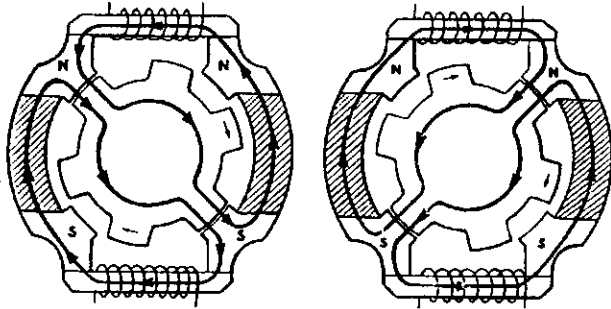

Fig. 15a

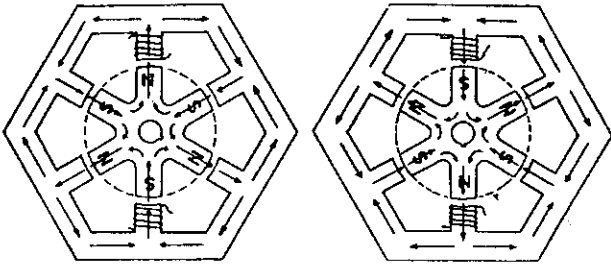
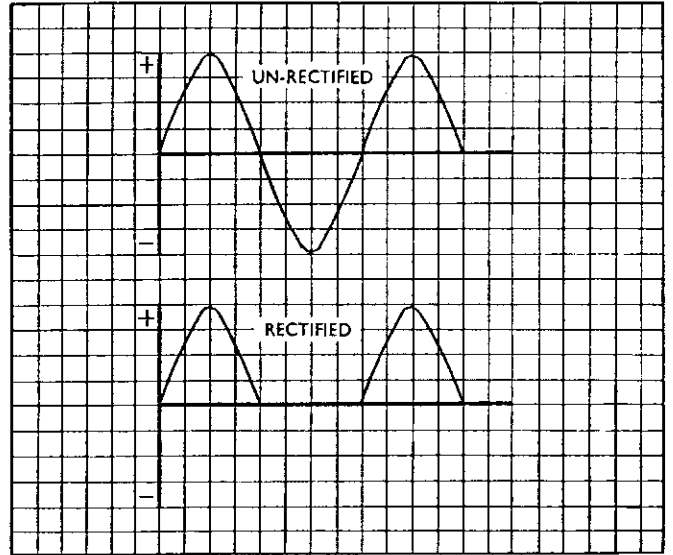

Fig. 15b

RECTIFIER FOR BATTERY CHARGING

Because of the alternating characteristic of the current produced by the alternator it cannot be connected directly to a battery for charging purposes. A battery can only be charged by a D.C. or unidirectional current. If a battery is to be charged by the alternator, then a rectifier must be incorporated in the circuit.



Figs. 17a (top) and 17b (bottom)

THE SINE WAVE

The sine wave shown in Fig. 16 is simply a representation of the sort of current output from an elementary alternator. It shows the current output during one complete revolution of the bar magnet alternator in Fig. 14.

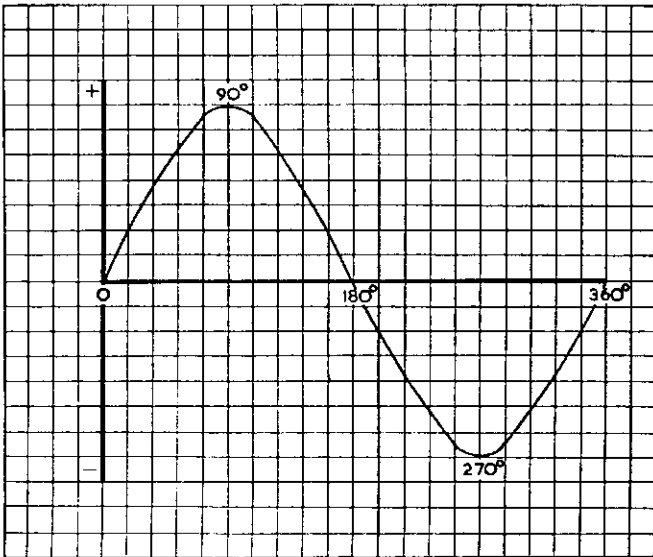

Fig. 16

The vertical line represents the amount of current in amperes, which is positive, above the neutral point or horizontal line; and negative below the neutral line. Starting from the left side, we divide this line into 360°, that is, one complete revolution of the bar magnet. From 0° the current gradually builds up to its maximum value at 90°; then gradually reduces, being zero again at 180°. It now carries on in the negative direction, reaching a maximum at 270°, then gradually reduces again, becoming zero at 360°. This cycle is repeated as long as the magnet is rotated.

A rectifier is a device for converting an alternating current, Fig. 17a, into a unidirectional current either by the suppression or inversion of alternate half-waves, Fig. 17b.

Both selenium plate and silicon diode type rectifiers are used with LUCAS A.C. sets. The formation of a selenium element is shown in Fig. 18. It consists of a steel base plate with selenium. A metal alloy is then sprayed on to the selenium, forming what is called a counter electrode. This combination of base plate, selenium and counter electrode has the property of allowing current to pass in one direction only, that is, from the base plate to the counter electrode. In practice, there is a small reverse current leakage, but from our point of view it can be disregarded.

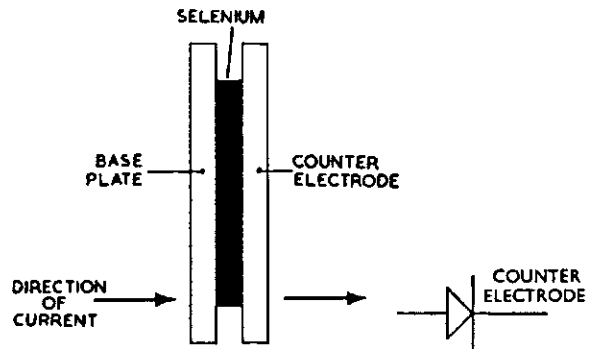

Fig. 18

Working Principles

With rectifiers of this type in the circuit, the generator can be connected up to charge a battery. The alternating output, which in effect would try to flow round the circuit, first in a clockwise direction and then in an anti-clockwise direction, becomes D.C. or unidirectional, and current therefore will always flow through the battery in one and the same direction, Fig. 19. The negative half waves, which are shown below the horizontal line, Fig. 16a, have been suppressed, and only the positive half waves above the line are allowed to pass through the rectifier and round the circuit. This arrangement is known as half-wave rectification.

In using this method of battery charging however, one half-cycle of our generator output is unused. In practice this problem is overcome by the use of a full-wave rectifier.

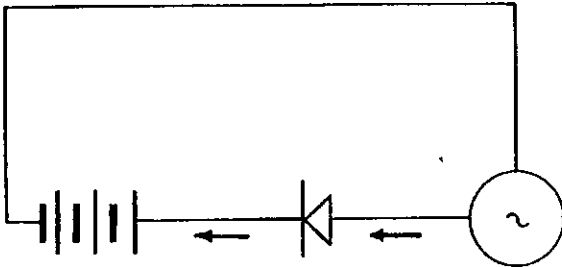

Fig. 19

FULL-WAVE RECTIFICATION

A full-wave rectifier consists of four elements, of the type shown in Fig. 18, connected so as to allow the full output from the alternator to pass through to the battery.

The illustrations in Fig. 20 show the bridge connected rectifier as it is called, connected in circuit with an alternator and battery. The left hand illustration (a) shows the circuit when current is flowing in a clockwise direction; the right hand illustration (b) an anti-clockwise direction. With this arrangement the full output from the generator is utilised. That is, both the positive half waves and the negative half waves are used to charge the battery. The efficiency of this type of rectifier is affected by the amount of tension on the plates, which are held together by a bolt and self-locking nut. The tension on this bolt is set correctly before leaving the works, and should not be tampered with in service.

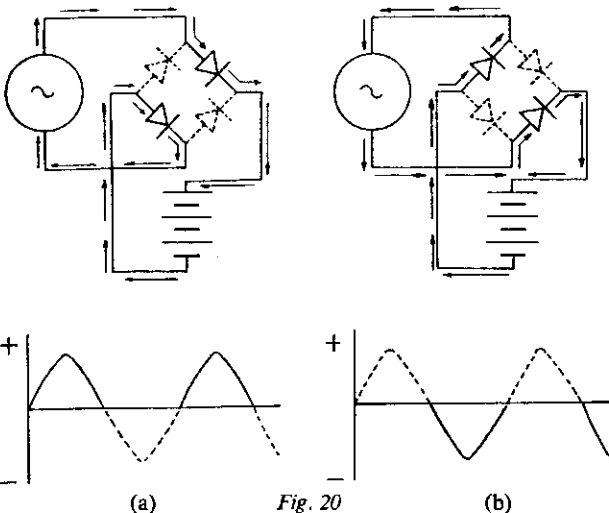

Fig. 20

Another type of selenium plate rectifier, used with the earlier model IA45 and RM12 alternators which have a centre tapped winding, is the two element type illustrated in Fig. 21.

Although structurally different from the bridge connected type, it performs a similar function, rectifying the full alternator output for battery-charging purposes.

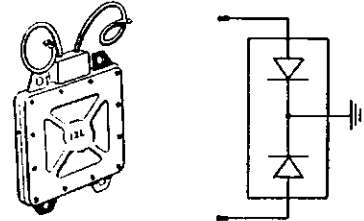

Fig. 21

Selenium plate rectifiers have now been superseded in service by the Silicon Diode rectifier. The silicon diode bridge rectifier incorporates four diodes, each mounted on a small circular plate which in effect constitutes a heat-sink. In appearance this type of rectifier resembles the small circular plate selenium rectifier, and in fact performs exactly the same functions. It is, however, much more robust and less prone to damage. A typical silicon diode bridge rectifier is illustrated in Fig. 22.

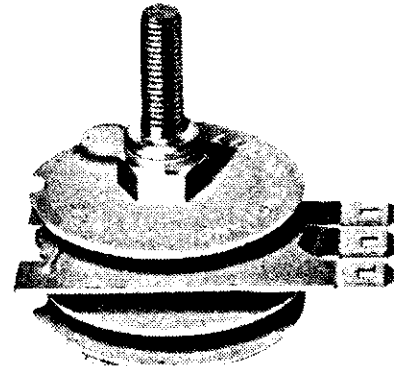

Fig. 22 Silicon diode bridge rectifier

CONTROLLING THE ALTERNATOR OUTPUT

The simple generator which has been described on page 8 is of course not satisfactory for normal requirements, and in practice contains not one, but several coils, each consisting of many turns of wire assembled to the stator, and the bar magnet becomes a multi-pole unit. The ampere output from such a machine is considerably more than would be obtained from the machine with the single coil and bar magnet. Some form of output control is necessary, otherwise the generator output would remain at a maximum irrespective of load requirements and the battery would eventually become overcharged.

Inductor Generator IA45

With the inductor generator, the method of output control is quite simple. A wire resistor, wound on a porcelain former is connected across the generator coil, as shown in Fig. 23.

The resistor is switched in or out of circuit automatically by operation of the lighting switch. When the resistor is in

Working Principles

circuit part of the generator output is dissipated in heat, reducing the amount of current which flows into the battery and thereby avoiding overcharging.

Because the resistor is controlled by the action of the lighting switch it will only be in circuit when it is required. With the lighting switch in the OFF position the resistor is in circuit and so reduces the generator output. When it is in the PILOT or HEAD position, an increase in load, the resistor is out of circuit allowing an increase in output to compensate for the increase in load.

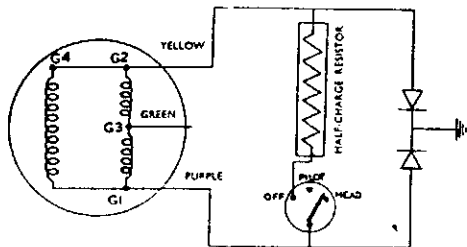

Fig. 23

Rotating Magnet Generators

Rotating magnet generators are also controlled by the action of the lighting switch, but instead of a resistor being used to reduce or control the output, the generator windings themselves are used.

The alternator stator, on the rotating magnet type, carries three pairs of series connected coils, one pair being permanently connected across the rectifier bridge network. The purpose of this latter pair is to provide some degree of charging current for the battery whenever the engine is running. Connections to the remaining coils vary according to the positions of the lighting and ignition switch.

With the ignition key in the IGN position, the basic output control circuits for rotating magnet alternators are as shown in Figs. 24a, b and c.

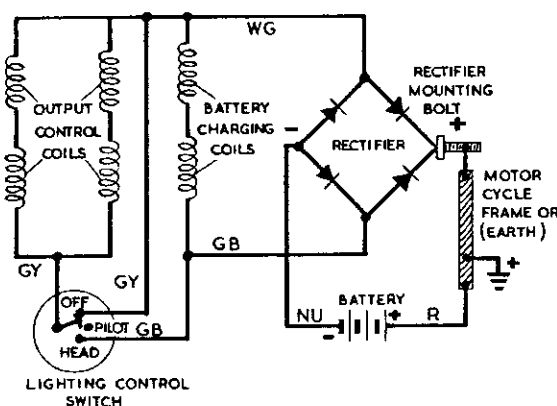

Fig. 24a Lighting switch in the "off" position

With the lighting switch in the OFF position, the output control coils are short circuited, as shown in Fig. 24a, and the alternator output is regulated to its minimum value by

interaction of the coil flux, set up by the heavy current circulating in the short-circuited coils, with the flux of the magnet rotor. Trickle-charging is provided by the permanently connected charging coils.

NOTE: On some machines taking the RM13 this arrangement has been modified, so that in the OFF position the control coils are not short-circuited but open-circuited, as in the PILOT position, giving an increased charge rate for normal running conditions.

In practice, this is achieved by taking out the link between terminals 5 and 6 on the lighting switch. This should be done in every case when servicing the earlier machines. The link is now omitted on production machines taking the RM13 A.C. set.

In the PILOT position, Fig. 24b, the control coils are disconnected and the regulating fluxes are consequently reduced. The alternator output therefore increases and compensates for the additional parking light load.

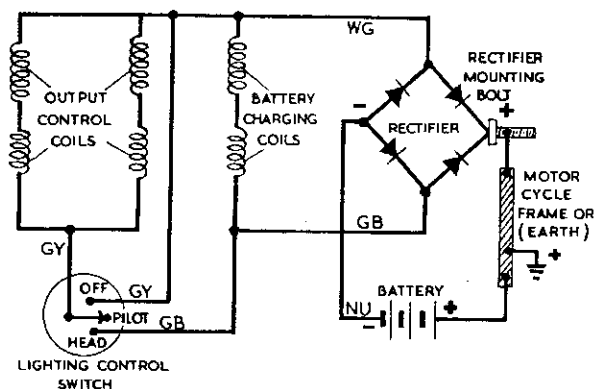

Fig. 24b Lighting switch in the "Pilot" position

In the HEAD position, Fig. 24c, the alternator output is further increased by connecting the control coils in parallel with the charging coils. Maximum output is now obtainable.

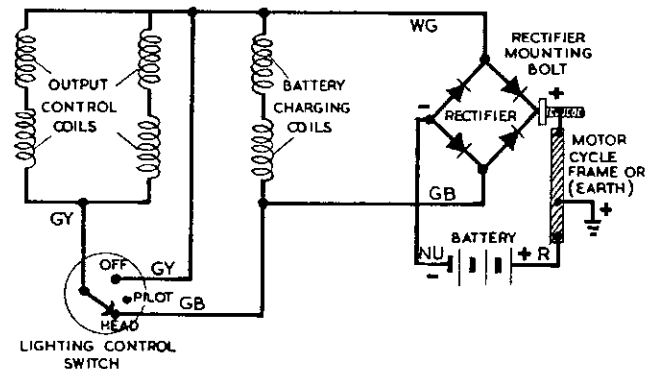

Fig. 24c Lighting position in the "Head" position

Special Control Applications

A.A. and Police machines fitted with two-way radio incorporate a separate "boost" control switch. This switch can be used at any time, irrespective of the position of the main lighting switch. When in the "boost" or closed position maximum output is obtained from the alternator,

Working Principles

see Fig. 25. When the switch is open the output from the alternator is dependent upon the position of the lighting switch.

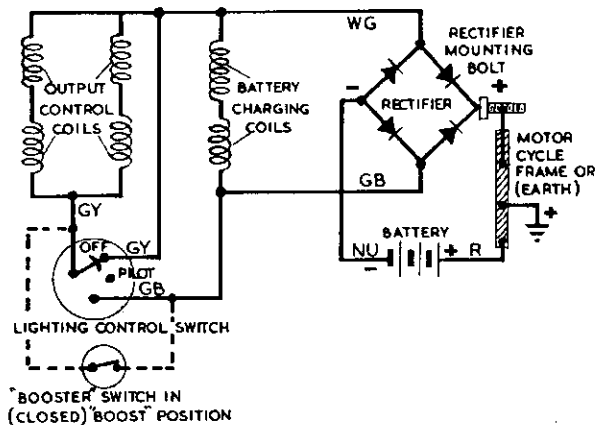

Fig. 25 Circuit with "Boost" switch in "Boost" position

The output of the earlier model RM12 series "C" machines is also controlled by varying the connections of the windings, through the action of the lighting switch, but the connections differ from those of the RM13 and RM14.

Six leads are brought out from the RM12 series "C" alternator, making the arrangement of the connections a little more complicated. However, the same principles apply, the coils being short-circuited or open-circuited as required, and the resultant interaction of the coil and rotor fluxes regulating the output accordingly.

The connections, with the lighting switch in the OFF, PILOT and HEAD positions are shown in illustrations Figs. 26a and b.

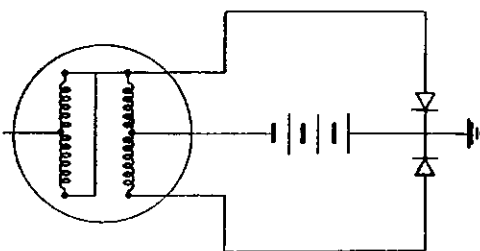

Fig. 26a RM12-Series "C". Arrangement of coils with lighting switch in "off" or "pilot" position

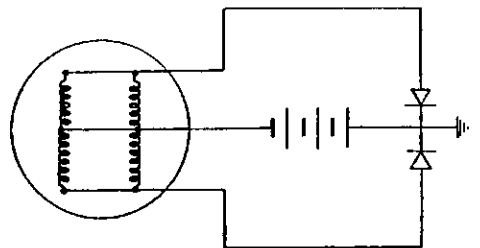

Fig. 26b RM12-Series "C". Arrangement of coils with lighting switch in "head" position

EMERGENCY STARTING

Motor cycles fitted with the alternator-rectifier battery charging system are normally provided with a means of

starting the engine in the event of an otherwise healthy battery becoming badly discharged. For this purpose, a three-position ignition switch is used, labelled "Ign.", "Off" and "Emg.". On switching to "Emg." and kick-starting the engine, the battery receives a charging current and, after a while, the ignition switch should be turned back to the normal running position "Ign.". (With the circuit as used on single-cylinder machines and on twins fitted with two ignition coils, the appropriate time to change back to normal ignition is indicated by a tendency for the engine to misfire, due to the rising battery voltage being in opposition to the alternator voltage—thus a steadily reducing amount of energy is available for transfer to the ignition coil).

The emergency starting feature also enables short journeys to be made (if absolutely unavoidable) without battery or lighting. This is done by connecting the cable normally attached to the battery negative terminal to an earthed point on the machine and kick-starting the engine with the ignition switch in the "Emg." position, Fig. 27.

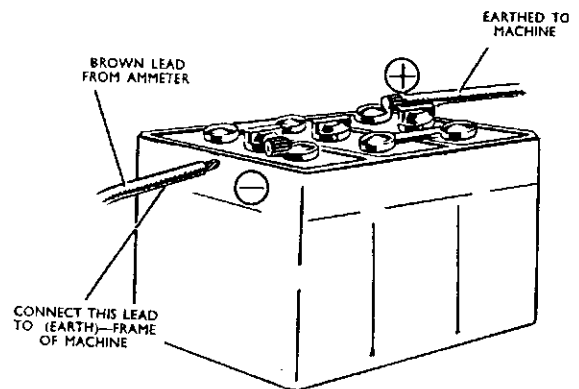

Fig. 27 Connections for running in "EMG" position without battery

Thus, a rider can make for home even if his battery has failed completely or has been pilfered. It must be emphasised, however, that continuous running under these conditions will result in badly burnt contacts in the distributor or contact breaker unit and cannot therefore be recommended.

Single-Cylinder Machines

When current flows through the windings in the direction indicated by the arrows in Fig. 28 and the contacts are closed, the main return circuit to the alternator is through one arm of the rectifier bridge. At the instant of contact separation, the built-up electro-magnetic energy of the alternator windings quickly discharges through an alternative circuit provided by the battery and the ignition coil primary winding. This rapid transfer of energy from the alternator to coil causes H.T. to be induced in the ignition coil secondary windings and a spark to occur at the plug.

When using a machine for trials or competition purposes, fitted with an RM alternator, and no lighting is required, the battery can be removed and the machine run continuously in the EMG position, providing the cable normally connected to the battery negative terminal is re-connected to an earthed point on the machine, see illustration in Fig. 27.

Working Principles

Kim The CD Man © 2003

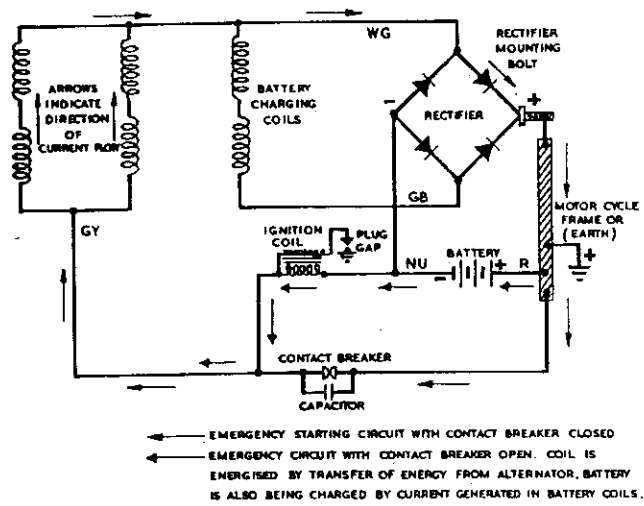

Fig. 28 Emergency Starting Circuit — Single Cylinder Machines

The inductor generator IA45, when connected for emergency start, has a conventional circuit, illustrated in Fig. 29. It will be seen from the illustration that the ignition coil primary winding, and the contact breaker are connected in series.

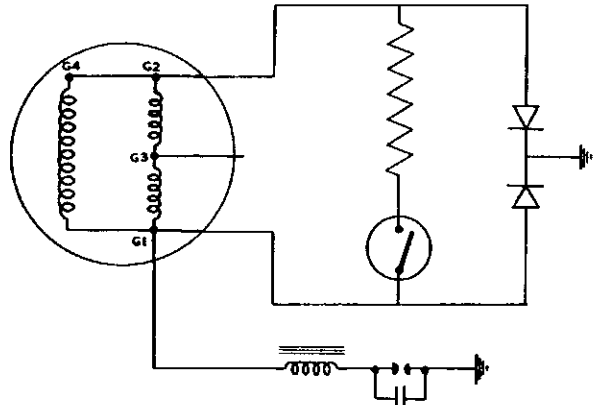

Fig. 29 IA45 — Connected for emergency starting

Also, the resistor is not connected in circuit allowing the full output to be utilised for ignition purposes.

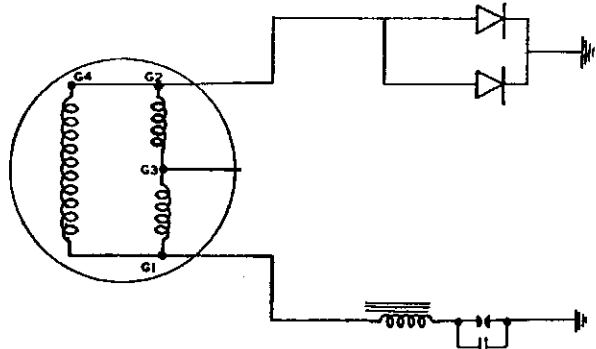

Fig. 30 IA45 — Connected for use without battery

As with the RM12 circuit, the battery does not receive a charge whilst running in the emergency position, so it is necessary to switch back to the IGN position if lighting or horn are to be used.

If it is required to use the machine for trials or competition purposes and no battery or lighting is required, then the circuit should be re-connected as shown in the illustration, Fig. 30.

Twin-Cylinder Machines (single ignition coil and distributor)

From Fig. 31 it will be seen that for twin cylinder machines the ignition coil primary winding and the contact breaker are connected in series, and not in parallel as for single cylinder machines. The adoption of this conventional practice permits a slightly more simple harness and switching system to be utilised. It is, however, unsuitable for use with single cylinder machines due to "idle" sparking occurring *before* the contacts separate. Twin engines when fitted with a distributor containing two electrodes, are unaffected by this premature sparking.

With single cylinder machines connected as shown in Fig. 28 "idle" sparking occurs *after* the contacts have separated and so does not affect these engines.

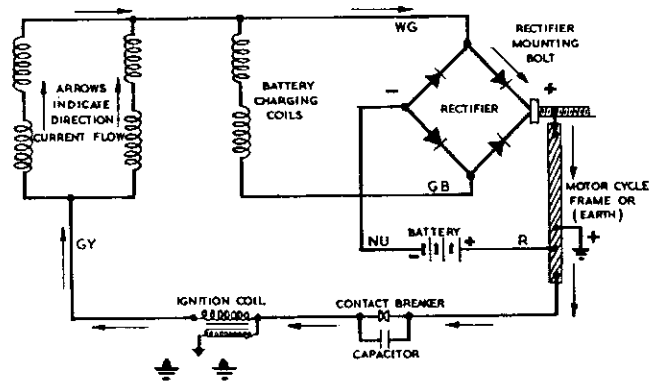

Fig. 31 Emergency starting circuit — twin cylinder machines with H.T. distributor. The H.T. coil and contact-breaker are connected in the conventional manner

Since with the emergency start circuit the battery receives a small charging current, causing the battery voltage to rise quickly, the machine should not be run, under normal conditions, continuously in the emergency start position, because the rising voltage of the battery opposes that of the alternator and gradually effects a reduction in the energy available for transfer to the ignition coil.

This reduction in spark energy will cause mis-firing to occur, which will, in fact, remind the rider that he has omitted to return the ignition key to the IGN position.

When using a machine for trials or competition purposes, fitted with an RM alternator, and no lighting is required, the battery can be removed and the machine run continuously in the EMG position, providing the cable normally connected to the battery negative terminal is re-connected to an earthed point on the machine, see illustration in Fig. 27.

Working Principles

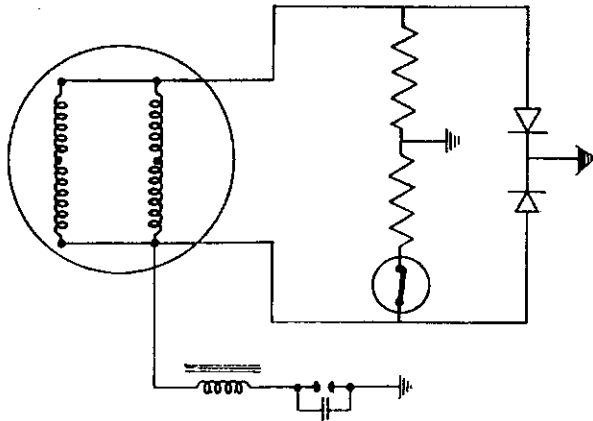

Fig. 32 RM12 — Series "C". Connected for emergency starting

RM12 Series "C" (Six Lead) — The circuit for emergency starting on this alternator differs from that used with the later machines. The arrangement of the stator coil winding differs; six leads are brought out instead of three. It is used in conjunction with a centre tapped rectifier (Fig. 21) and a resistor is connected across the alternator to allow for continuous running in the EMG position.

A disadvantage with the RM12 layout is that the battery does not receive a charge whilst the machine is being run in the emergency start position and, without a battery, it is not possible to use the lighting or horn. The illustration in Fig. 32 shows the emergency start circuit layout for the RM12 Series "C" alternator.

As with the RM13 and RM14 sets, the brown lead connected to the battery negative terminal should be reconnected to an earthed point on the machine, for trials or competition purposes, as shown in Fig. 28.

Twin-Cylinder Machines (twin ignition coils and twin contact-breakers)

With the ignition switch in the normal running position IGN, each coil, with its associated pair of contact-breaker contacts, serves one of the cylinders — each functioning as an ordinary battery coil ignition circuit. On switching to EMG, however, one of the ignition coils functions on the energy transfer principle.

The illustration (Fig. 33) shows the circuit used for emergency starting. With this circuit the No. 1 contact-breaker is arranged to open when the alternating current in the windings reaches a maximum in the direction shown by the large arrows. The circuit functions as follows:

With the contacts closed the main return circuit to the alternator is then via one arm (element) of the rectifier bridge and the closed contacts. In effect the four output control windings have been short-circuited allowing a heavy current to build up and circulate through them.

At the instant of contact separation this built-up energy quickly discharges through an alternative circuit provided by the battery and primary winding of the No. 1 or EMG ignition coil. The rapid transfer of current from alternator to ignition coil primary results in H.T. being induced in the secondary winding and an efficient spark, at the plug.

The efficiency of the energy transfer ignition is quite high because the alternative circuit through the battery, when the contacts are opened, is virtually a short-circuit

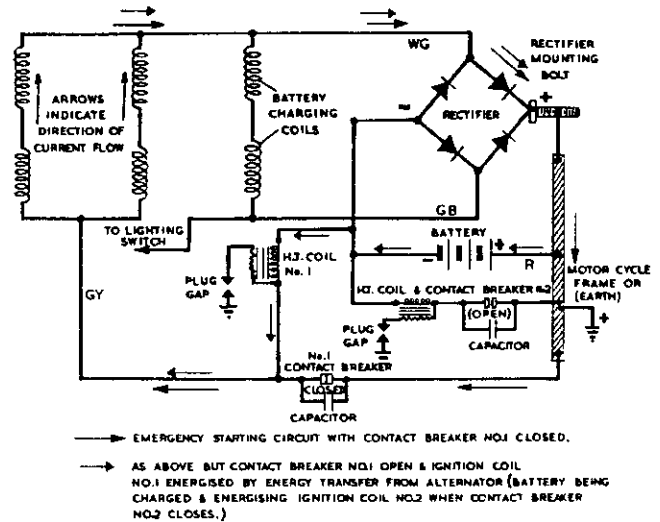

Fig. 33 Emergency starting circuit — Twin cylinder machines (with two ignition coils and double contact-breaker unit)

path owing to the fact that the "flat" battery has little or no potential difference across it. Therefore, very little energy is lost at this point.

However, due to the fact that the current surges do pass through the battery, and the fact that the two permanently connected charging coils are also in circuit, the battery begins to build up a potential difference across its terminals until, after several current pulses, assuming the engine has fired and is running on one cylinder, it gradually effects a reduction in the amount of energy available for transfer to the ignition coil. This reduction in spark energy will cause misfiring to occur, which in the event of the rider omitting to return the ignition key from position EMG to IGN, serves as a reminder to do so. The contact points will be badly burnt if the rider prolongs running in the EMG position.

Another feature of the system is that coil No. 2 eventually comes into operation during emergency starting, so that after a few seconds running on one cylinder, number two cylinder cuts-in and the engine functions as a normal twin-cylinder unit. The fact that it will operate on both cylinders after a few seconds does not detract from the statement, made in the previous paragraph, about the rising battery voltage causing misfiring to occur.

Although the No. 2 coil "SW" terminal is linked to the same feed cable as the "SW" terminal of No. 1 coil, it does not pass any of the energy transferred from the alternator, during the "energy transfer" pulse, as at this particular instant the No. 2 contact-breaker points are open, open-circuiting the No. 2 coil primary circuit. It is fed eventually however, because the battery voltage or potential difference builds up due to the current from the alternator passing through it, causing the battery to assume a stronger polarity characteristic. And therefore, in between the No. 1 coil being fed by energy pulses from the alternator, the No. 2 coil will, when its associated contacts close, receive current direct from the battery which is gradually becoming charged. This results in the engine firing on both cylinders. It will not run at full power until switched to the IGN position, because the energy now available for the

Working Principles

No. 1 coil is being reduced and misfiring will still occur.

Actually, during the stage when both coils are functioning their primary windings are being fed in opposite directions. The No. 1 coil is receiving pulses from the alternator, via the battery, the insulated side of the circuit, through the primary from "SW" to "CB" and back to the alternator. The No. 2 coil is fed by a steady current direct from the battery, via earth, through No. 2 contacts to "CB", through primary to "SW" and back to battery "-ve".

Ignition performance under emergency starting conditions should be equivalent to that of a magneto at kick-start speeds.

NOTE

If emergency starting is necessary on a machine fitted with a "boost" control switch, the switch must be in the off position before attempting EMG starting. Otherwise, the emergency starting system will be shorted-circuited.

THE IMPORTANCE OF CORRECT TIMING FOR EMERGENCY IGNITION

Correct ignition timing, both electrically and mechanically, is a very critical factor with the A.C. sets, particularly in relation to emergency starting. As already stated, in the emergency start position the alternator supplies current direct to the ignition circuit, timing being so arranged that the contacts are opened when the peak of the voltage wave coincides with each firing point of the engine, illustrated graphically in Fig. 34(a).

It will be realised that if for any reason the contacts do not open at the precise instant required, emergency starting performance will be affected. Electrically, the timing position is fixed by the manufacturer, i.e., the alternator rotor is keyed on to the crankshaft in a position consistent with peak voltage, and cannot be altered. It is on the mechanical side that variations in timing can arise. The engine ignition timing must be accurately set to the figures specified for the particular machine. The contact breaker

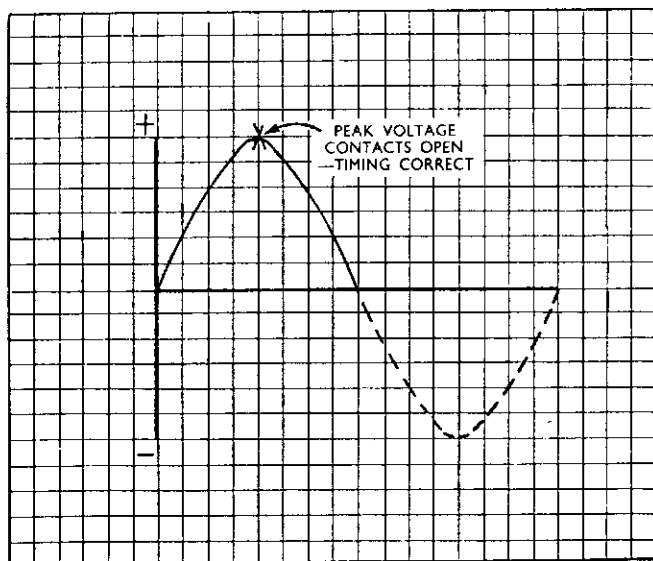

Fig. 34a Timing correct as it coincides with maximum generator voltage

gap must also be set to the specified figure and maintained at this as variation in the gap setting will affect the timing position in relation to spark energy. If the timing at the distributor or contact breaker is too much advanced or retarded, either through a timing error, incorrect contact gaps, or weak automatic advance springs, the contacts will not open at the peak of the voltage curve, see Fig. 34(b) consequently the spark will be weak.

REMEMBER IGNITION TIMING IS CRITICAL

FAULTS WHICH GIVE RISE TO POOR EMERGENCY STARTING

Faulty or dirty connections anywhere in the alternator electrical circuit will obviously have a bad effect on performance. The points to watch for particularly are bad earth connections at the battery and rectifier. Both units are connected to the frame of the machine and a periodic check should be made to see that the connections are tight. Remember that the battery "+ve" terminal is the one earthed to the frame of the machine.

Dirty Contacts or Incorrect Gap Setting

The contact-breaker points should be periodically checked and cleaned if necessary, also the gap should be checked and maintained as its correct setting, i.e., 0.014" - 0.016". This applies to both contact-breaker units.

Dirty Plugs or Incorrect Gap Setting

Plug gaps should be periodically checked and if necessary adjusted to the required gap, as specified by the manufacturer. It is also very important that the external insulator is kept clean and dry. Plugs should be replaced if the electrodes are badly worn.

Faulty Rectifier

A rectifier can be faulty, due to ageing which is an inherent characteristic, even though its external appearance may suggest it is in good working order. There is only one way of finding out and that is by removing it from the machine and carrying out a bench test.

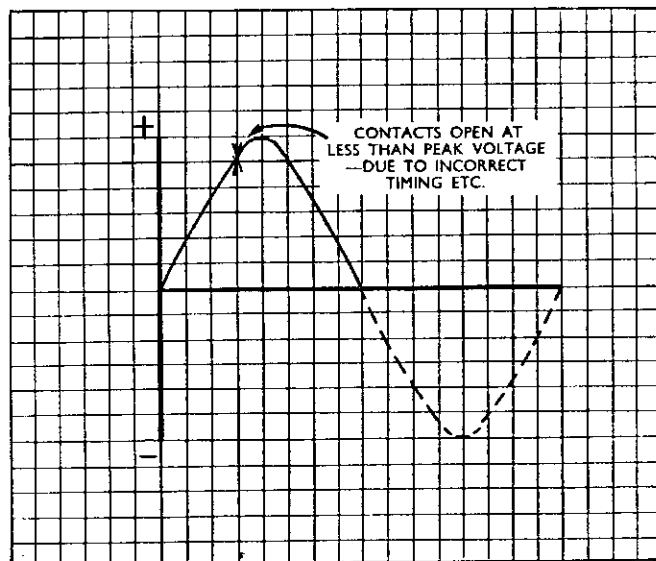

Fig. 34b This illustration shows the effect of over-advanced timing. Retarded or late timing will produce a similar effect because the contacts will open after maximum voltage has been generated

Working Principles

Rectifiers should be kept clean and dry and so fitted as to allow air to circulate freely through the plates for cooling purposes.

Dirty or Corroded Battery Terminals

Battery connections should be kept clean and tight, particularly the one made to the frame of the machine. It is also important to keep the top of the battery clean and dry.

Sulphated Battery

A sulphated battery is usually the result of lack of maintenance, i.e., failure to maintain the electrolyte at the specified level, and allowing the battery to remain for long periods in a partially charged or discharged condition. A regular check on each cell should be made to see if it requires "topping-up" and if necessary distilled water should be added to the electrolyte to bring it up to the correct level.

A.C. IGNITION

An alternator designed for A.C. ignition has the ignition generating coils connected in series with each other and with the primary winding of a special ignition coil. The earlier model coil is known as the 2ET, the current model is called the 3ET, (Figs. 35 and 36).

These special ignition coils employ a closed iron circuit and have a primary winding whose impedance is closely matched to that of the ignition generating coils of the alternator. As a result of this electrical matching the ignition performance combines the good top speed characteristics of the magneto with the good low speed performance of the conventional ignition coil.

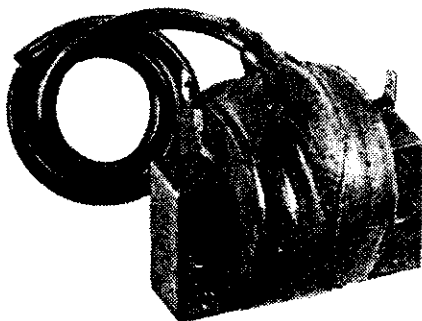

Fig. 35 Model 2ET Ignition Coil

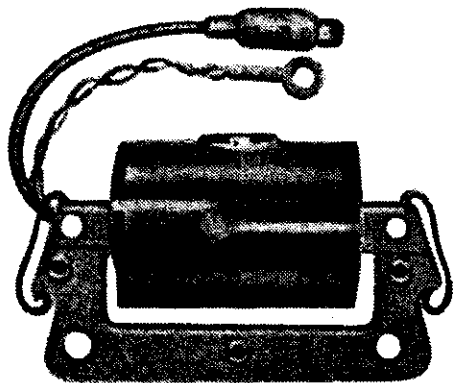

Fig. 36 Model 3ET Ignition Coil

The A.C. ignition system functions as follows:

The contacts of a contact-breaker unit or distributor are connected in parallel with the ignition coil primary windings, since one end of the stator winding, one end of the ignition coil primary winding and one side of the contact-breaker is earthed, as shown in Figs. 37 and 38.

Closure of the contact-breaker contacts short-circuits the ignition coil primary winding and, at the same time, creates a closed circuit of the stator ignition windings. As the magnet rotor turns, voltages are induced in the stator coils giving rise to alternating currents during the period that the contacts are closed. At the instant of contact opening, however, a pulse of electro-magnetic energy (developed in the stator during the contacts closed period) is discharged through the ignition coil primary winding. The effect of this energy pulse in the primary winding is to induce a high tension voltage in the ignition coil secondary winding which is then applied either directly or by way of a distributor to the appropriate sparking plug.

Timing considerations

Since the magnetic rotor of the alternator is keyed or otherwise located on the crankshaft, the magnetic pulse in the alternator stator, which produces the energy pulse to feed the ignition coil primary winding, must be timed to occur at the firing point of the engine.

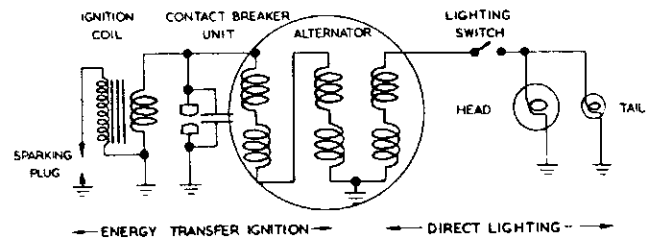

Fig. 37 A.C. ignition and direct lighting

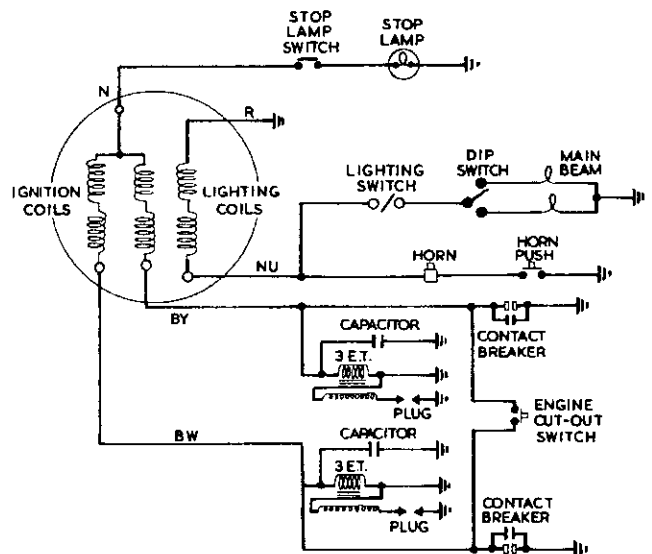

Fig. 38 A.C. ignition and direct lighting circuit for a twin-cylinder machine, using double contact-breakers and twin E.T. ignition coils

Working Principles

The magnetic pulse occupies several degrees of crankshaft (and therefore of rotor) rotation. A fairly wide angular tolerance would thus be available for a fixed ignition engine.

However, it is desirable with most four-stroke engines to incorporate an ignition timing control (usually centrifugally operated) giving a range of advanced and retarded sparking. The magnetic relationship of the alternator rotor to its stator must therefore be governed by this fact, namely, that the engine firing point will vary by several degrees between the fully retarded starting condition and the fully advanced running condition.

This is exactly the same problem which obtains with a manually controlled magneto and gives rise to the same characteristics, i.e., the available sparking voltage for a given kick-start speed reduces progressively with the amount of retard angle. A magneto, however, is a self-contained unit and will produce a spark however grossly it may be mistimed to the engine. This is because a magneto contact-breaker is always in correct relationship to the magnetic geometry of the unit. With an alternator, however, the position of the magnetic rotor with respect to the stator, and to the engine piston at the instant of firing, is pre-determined by its located position on the engine crankshaft.

The range of retarded magnetic timing that can be used with a particular engine depends in part on that engine's startability, since the required plug voltage is influenced by many factors of engine design. The speed at which it can be kicked over in attempting to reach this voltage will depend on piston and bearing friction, kick-starter ratio, etc.

The characteristics reproduced in Fig. 39 show how the available plug voltage varies with different magnetic timing positions and for different speeds of rotation. The reference point is known as the Magnetic Neutral position, when the interpolar gaps of the rotor are situated on the centre-lines of the stator limbs.

It will be seen that whilst the optimum magnetic position is some 4° past the Magnetic Neutral at 200 rev/min, it changes to some 12° past at 2,000 rev/min, due to distortion of the magnetic flux.

It will also be seen that the sparking performance deteriorates rapidly a few degrees before the Magnetic Neutral position. Hence commercial tolerances on keyways, etc., dictate the inadvisability of approaching too near to this critical point in the advanced or running position of engine timing.

As previously stated the extent to which the retard timing can be used depends on plug voltage requirements at starting and on kick-starter speed.

For example, if the required plug voltage is 6 kilo-volts, the retarded timing would be restricted to about 20° (engine) if the kick-starting speed was to be limited to 200 rev/min - in practice, a fairly low speed. On the other hand, at the fairly normal kick-starting speed of 400 rev/min, a timing range of some 30° could be accommodated with plug voltages up to about 8 kilo-volts.

It will be appreciated, therefore, that accurate ignition timing is an important requirement in the operation of an engine transfer system. The optimum conditions are

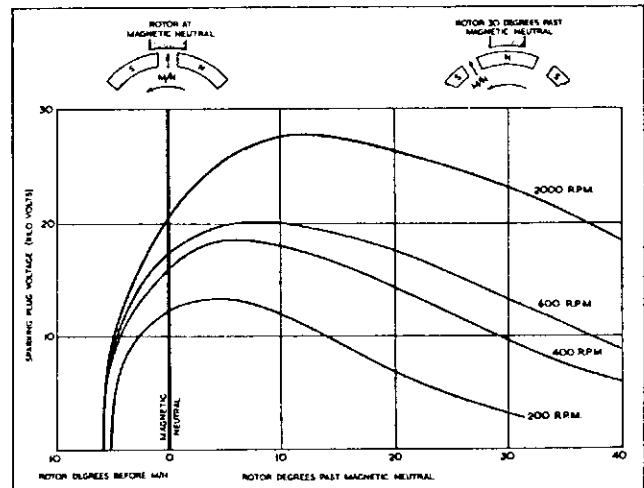

Fig. 39 Curves showing how sparking plug voltages depend on magnetic timing and kick-starting speeds

determined by the engine designers during the development stages and these conditions should always be maintained in order to ensure the highest performance, both from the engine and from the ignition system designed to work with it.

It will also be appreciated that amateur tuning, departing from the designers' recommendations, cannot be expected to improve a highly developed engine. Indeed, some harmful results may occur. For this reason, indifferent sparking outside the prescribed range will almost certainly indicate tampering and may well serve as a warning to the would-be tuner.

ZENER DIODE CHARGE CONTROL

The new LUCAS Zener Diode Charge Control for 12-volt alternator equipped motor cycles eliminates over-charging of the battery and permits the use of extra accessories such as flashing direction-indicators and a fog or long range driving lamp. With coil ignition machines, four coils of the conventional alternator are permanently connected across the rectifier. With magneto ignition, two coils are so connected. The Zener Diode is connected in parallel with the 12-volt battery (or two 6-volt batteries connected in series) between the ignition coil feed-wire terminal of the ignition switch and the Diode heat-sink, which is at "earth" potential.

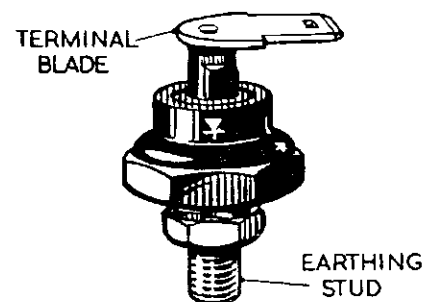

Fig. 40 Zener Diode

Working Principles

FUNCTION OF ZENER DIODE AS A CHARGING CURRENT REGULATOR

The illustrations in Fig. 41 show how the Diode is connected into the alternator circuit. Bearing in mind that it is in *parallel* with (or shunted across) the battery, it operates as follows:

Assuming the battery is in a low state of charge, its terminal voltage (the same voltage is across the Diode) will also be low, therefore the maximum charging current will flow into the battery from the alternator. At first none of the current is by-passed by the Diode, the latter being non-conductive due to the low battery terminal volts. However, as the battery becomes recharged its terminal voltage rises until, at approximately 14 volts, the Zener Diode, which up to this point has opposed the passage of current, becomes partially conductive, thereby providing an alternative path for a small part of the charging current. Further small increases in battery voltage result in large increases in Zener conductivity until, at approximately 15-volts (the on-charge voltage of a fully charged 12-volt battery), about 5 amperes of the alternator output is by-passing the battery. The battery will continue to receive only a portion of the alternator output as long as the system voltage is relatively high.

Depression of the system voltage, due to the use of headlamp or other lighting equipment, causes the Zener Diode current to decrease and the balance to be diverted and consumed by the component in use. If the electrical loading is sufficient to cause the system voltage to fall below 14-volts, the Zener Diode will revert to its high resistance state of virtual non-conductivity and the full generated output will go to meet the demands of the battery.

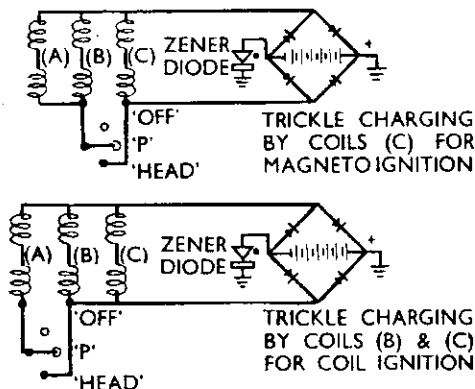

Fig. 41 Motorcycle alternator circuits with Zener Diode Charge Control

To prevent overloading of the Zener Diode (which has a nominal current rating of 5 amperes) some form of switching is still required. In lighting switch positions "Off" and "P" four coils of the stator are permanently connected across the rectifier for coil ignition circuits, and two coils for magneto circuits. In the "Head" position full alternator output is obtained by connecting all six coils across the rectifier. This is shown in Fig. 41. The Zener Diode is normally connected so that it is switched "in" and "out" of circuit by the action of the ignition switch.

Some 1966 motorcycles already incorporate another variation of the Zener Diode Charge Control. All six coils

are permanently connected to give a continuous maximum output, there is no provision for varying it through the action of the lighting switch. In this application the Zener Diode is mounted on a heat-sink of approximately 36 sq. in. in area, which is positioned so that the maximum amount of air can flow over it. The alternator coil connections, on earlier machines, are made by joining together the external cables Green/Black and Green/Yellow. Eventually these connections will be made internally, on the stator windings. Page 84 shows the complete wiring circuit for this new system. Simplified switching and wiring circuits are possible with this arrangement, as compared with earlier systems.

Caution

Do not attempt to convert existing machines to this new system, unless the Zener Diode is first mounted on a heat-sink of not less than 36 sq in, and can be positioned on the machine so that the maximum cooling effect is obtained. It *must not* be fitted in any position where the air flow is poor, otherwise premature failure of the diode will ensue.

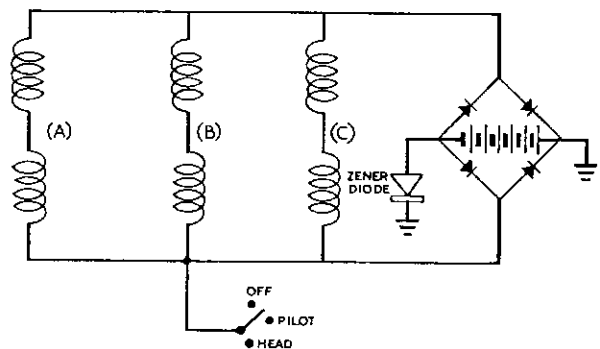

Fig. 42 Latest alternator circuit with Zener Diode Charge Control, full output from coils "A", "B" and "C" is obtained irrespective of position of lighting switch

Conversion of existing 6-volt alternator equipped Motorcycles to 12-volt — With Zener Diode Charge Control

Full details for carrying out the conversions are given in Publication No. 2380, available on request, together with a list of all of the various models of motor cycles, which can be converted to this new method of charging control. General details of the equipment required are given on pages 28 to 31.

CLIPPER DIODE — VOLTAGE STABILISER FOR MACHINES FITTED WITH DIRECT LIGHTING SYSTEMS

A common fault experienced with machines equipped with Direct Lighting is the blowing of bulbs. This may be due to faulty dipper switches, causing momentary voltage surges, bad connections or indefinite earths, or purely excessive voltage generation caused by improper design probably amplified by wide production tolerances in the manufacturing of the generator units. Whichever is the cause, the Clipper Diode will effectively protect the bulbs against filament failure. The diode will not offer protection against vibration, filament fractures or faulty bulb manufacture.

Working Principles

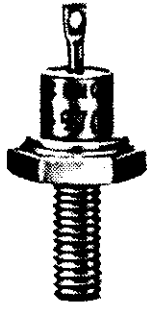

Fig. 43 Clipper Diode

The diode is wired into the circuit so that when the lights are switched on, the generator is also feeding the diode. This can be achieved by connecting either into the Tail-lamp feed or the wire supplying the Dipper Switch. If no Dipper Switch is used, the connection would be made directly to the Headlamp bulb feed.

Function of Clipper Diode as a Voltage Stabiliser

The Clipper Diode, as its name implies, limits or clips the positive and negative peaks of the generated voltage when it exceeds a certain maximum level, and in effect maintains or stabilises the system voltage at a constant safe value. It can be likened to an opened switch, in its non-conductive state, until the generated voltage exceeds the required system voltage, then it automatically closes, becomes conductive, dissipating the excess power in the form of heat. The Zener breakdown voltage of the diode is 9 — 11 volts.

It should be remembered that the Clipper Diode is in effect two Zener Diodes in a back-to-back arrangement, as both positive and negative voltage pulses need to be limited.

General Servicing Information

INCREASED CHARGING RATES — 6-VOLT A.C. EQUIPPED MACHINES

During the winter months, when motor cycles are used mainly for short journeys, and parking lights are used more frequently, motor cyclists find, that on A.C. equipped machines, it is sometimes difficult to maintain the battery in a fully charged condition.

It is not possible to increase the maximum output of the alternator (i.e., when the lighting switch is in the head-lamp position), but an increase in output is obtainable in the "off" and "pilot" switch positions. This is achieved simply by interchanging the green and yellow (or mid green) and green and black (or dark green) leads at the snap connectors where the alternator leads join the main harness.

A greatly increased charge rate is obtained with the alternative connections and we do, therefore, recommend that they are used only whilst making short journeys during the winter months. If a long journey is necessary, the original connections should be restored.

It is appreciated that changing the leads at the connectors is not entirely convenient. Fortunately, it is possible to modify the wiring to incorporate a switch for this purpose. The wiring modifications are simple, although differing slightly, according to the type of ignition switch fitted to the machine. In each case, however, the same switch, part number 31757, is required. This switch has "Lucar" type terminals, so that "Lucar" connectors will also be required. Connectors and plastic covers can be obtained in packets of 10 under part number 54942078 and 54190042 respectively.

Machines with PRS8 Lighting/Ignition Switch or 63SA or 88SA Ignition Switches

Remove the alternator green and yellow (or mid green) lead from terminal 16 on the lighting/ignition or ignition switch, and connect instead to terminal No. 2 on the changeover switch. (See diagram 1). Connect a new lead from terminal No. 3 on the changeover switch to terminal No. 16 on the light/ignition or ignition switch. Remove the alternator green and black (or dark green) lead from the rectifier terminal, but do not remove the other lead at this rectifier terminal which is connected to the lighting switch.

Connect the lead removed from the rectifier to terminal 5 on the changeover switch and a new lead from terminal No. 6 on same switch back to the rectifier terminal from which the alternator lead was removed.

Machines fitted with PR1/2 Ignition Switch

The same instructions as above apply, except that the alternator green and yellow (or mid green) lead is removed from terminal 11 of the PR1/2 switch. (See diagram 2.). This lead is still connected to terminal No. 2 on the changeover switch, whilst the new lead from terminal No. 3 on the switch is now connected back to terminal No. 11 on the ignition switch.

Special Notes:

Due to the type of connections employed on the 63SA and 88SA switches, we recommend that to make these alterations the lead is cut a few inches from the ignition

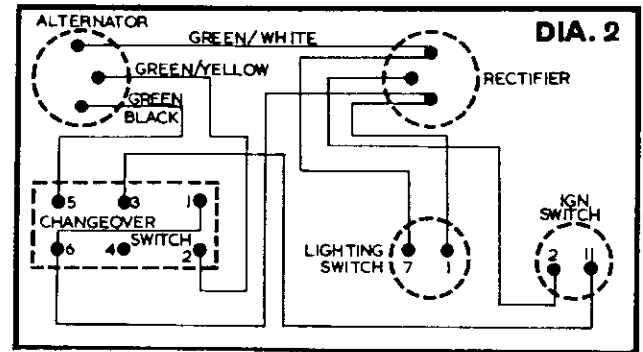
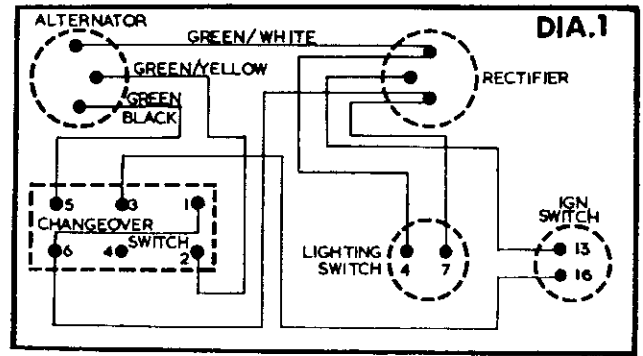

switch and the new connections made with the aid of snap connectors.

Changeover switch must be in the normal charge position if it is necessary to start the machine in the emergency position, although once the ignition switch has been turned to normal ignition position, the changeover switch can be returned to the high charge position.

IGNITION WARNING DEVICES

Many motor cyclists would like some form of warning device which would indicate that the ignition has inadvertently been left on, a state of affairs which usually results in a flat battery.

With motor cycle A.C. circuits it is not possible to fit, at reasonable cost, an ignition warning light which will function in exactly the same manner as on D.C. equipped machines. But, if a warning light is connected in parallel with the ignition coil, it will remain on as long as the ignition switch is on and would, therefore, provide a reliable warning.

Simple to install, the warning light body is earthed to the frame of the machine and the single lead is connected to the feed lead which connects the ignition switch to the ignition coil. Either the ignition switch or coil terminal would be suitable connecting points.

WIRING MODIFICATIONS — WHEN CONVERTING A.C. EQUIPPED MACHINES FROM COIL TO MAGNETO IGNITION

Some owners preferring magneto ignition modify their coil ignition alternator equipped machines to magneto operation. However, it must be remembered that it is still necessary to turn the ignition key to the "on" position on

General Servicing Information

converted machines before the alternator can charge the battery. This could easily be overlooked, and as continuous running in this condition will almost certainly damage the rectifier, we recommend the following wiring modifications depending upon the type of lighting/ignition switches.

Machines fitted with PRS8 combined Lighting/Ignition Switches

Remove the Brown/Purple or Purple lead from terminal No. 13 on switch and connect into switch terminal No. 12. Remove the lead from terminal 18 and connect instead into terminal No. 16.

Machines fitted with 63SA or 88SA separate Lighting and Ignition Switches

Disconnect the Brown/Purple or Purple lead joined to terminal 13 on ignition switch and connect to the lead joined to terminal 12.

Disconnect the lead at terminal 18 and connect now to terminal 16.

Note:

Due to the type of connections employed on these switches, we recommend that to make these alterations, the lead is cut as close to the switch as possible, and new connections made with the aid of snap connectors.

Machines fitted with 41SA Lighting Switch and PR1/2 Ignition Switch

Move the Brown/Purple or Purple lead from terminal 2 to terminal 4 on the ignition switch, and similarly move the Green and Yellow lead from terminal 11 to terminal 13.

Once the appropriate modifications have been made, the ignition switch will no longer be operative.

RM12 ALTERNATORS

Both the RM12 Series "A" (four lead) and Series "C" (six lead) alternators are now obsolete, but the stators are still being serviced on a repair only basis.

However, it has been necessary to use currently available cable, in order to keep costs to a reasonable figure.

In cases where the stator has been repaired, the new leads should be connected to the main harness, in accordance with the following instructions:

RM12 Series "A" four lead Stator

New Stator Lead Colour	connect to	Existing Main Harness Cable Colour
Purple		Purple
Tan		Red
Light Green		Yellow
Mid Green		Green

RM12 Series "C" six lead Stator

New Stator Lead Colour	connect to	Existing Main Harness Cable Colour
Purple		Purple
Brown		Buff
Light Green		Yellow
Dark Green		Slate or Grey
Mid Green		Green
Tan		

*Connect these leads to Green by using the existing double snap connector.

RM13/14/15 ALTERNATORS

When these alternators were introduced, the three output cables were Light Green, Mid Green, and Dark Green.

It was observed that, after long service, these colours were affected by oil and atmospheric conditions, and it became difficult to distinguish the individual colours. To assist identification, the Mid Green cable was modified to Green and Yellow.

Later, for the same reasons, it was decided to modify both Light Green and Dark Green cables to Green and White, Green and Black respectively.

Original	Intermediate	Later
Light Green	Light Green	Green and White
Mid Green	Green and Yellow	Green and Yellow
Dark Green	Dark Green	Green and Black

FITTING A "LUCAR" SERVICE CONNECTOR

STAGE 1.

THREAD THE INSULATING COVER OVER THE CABLE



STAGE 2.

STRIP INSULATION NEATLY FROM CONDUCTORS

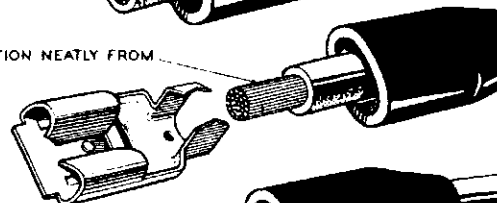

STAGE 3.

FEED CONDUCTORS THROUGH APERTURE & GRIP CABLE FIRMLY IN TAGS

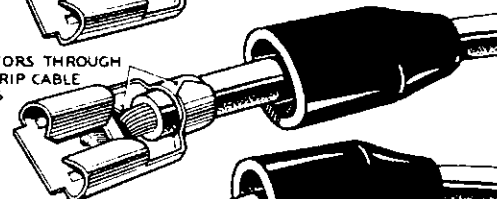

STAGE 4.

SPRAY CONDUCTORS BACK TOWARDS CABLE & SPREAD FLAT

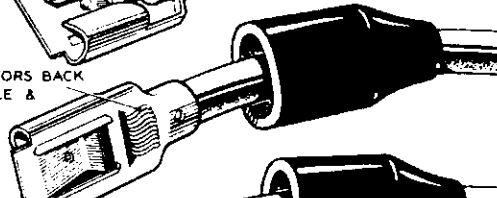

STAGE 5.

SOLDER SECURELY & NEATLY TO CONNECTOR DO NOT ALLOW SOLDER TO RUN FREELY THROUGH APERTURE

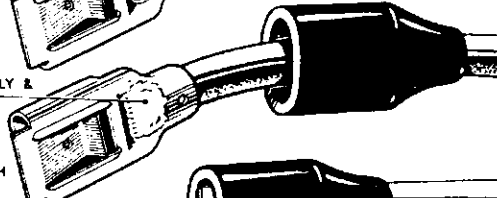

STAGE 6.

ALLOW THE JOINT TO COOL THEN SLIDE THE COVER OVER THE CONNECTOR



General Servicing Information

USING THE MACHINE FOR TRIALS OR COMPETITION PURPOSES

If the machine does not incorporate A.C. ignition, it can be used without a battery, and in the EMG. position, provided the lead which comes from the main harness and connects to the battery negative terminal, is earthed to the frame of the machine.

If an IA45 alternator is fitted, re-connect leads as shown in Fig. 30.

PRS8 SWITCH — CONNECTIONS

The connector linking terminals "5" and "6" of this switch must be discarded if no connector was fitted between these terminals on the original switch.

Single-Cylinder Machines

The wire-link connections of this switch are arranged to control A.C. Lighting-Ignition Sets as fitted to single-cylinder machines.

Twin-Cylinder Machines

If this switch is required to control an A.C. Lighting-Ignition Set on a multi-cylinder machine, one of the wire-link connections must be modified as follows:

- (i) Disconnect and remove the wire which passes across the back of the switch from Terminal 14 to Terminal 19.
- (ii) Shorten this wire and re-connect it between Terminal 14 and Terminal 15.

WARNING — USE OF D.C. SUPPLY FOR CONTINUITY TESTS

Under no circumstances should a D.C. supply be used for checking the continuity of the stator windings, unless a bulb of low wattage or resistor, is used in series with the test leads.

SECURING A SILICON DIODE RECTIFIER

The central fixing bolt of the rectifier must make electrical contact with the frame of the motor cycle. When tightening a rectifier hold the spanners as shown in the illustration right. Never disturb the self-locking nut which clamps the plates together. If the plates are twisted the electrical connections will be broken. Note that the fixing bolt and nut are $\frac{1}{4}$ x 28 U.N.F. thread and are both marked by circles to indicate this thread form.

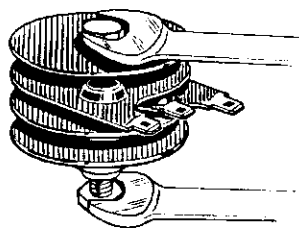

Fitting Model 41SA Service Replacement Lighting Switch—Part Number 31763

This switch can be used to replace Model 41SA Lighting Switch, Service Number 31754.

It will be seen that this switch has six terminals whereas the original switch had only four terminals. When fitting the new switch, the extra two terminals, numbers "6" and "7", are not used – the remaining four terminals being connected up in the same manner as the original switch.

Fitting Model 41SA Service Replacement Lighting Switch—Part Number 31676

This switch can be used to replace Model 41SA Lighting Switch, Service Number 31626, fitted to some 1956/57 Norton and Ariel Single and Twin Cylinder Motor Cycles.

It will be seen that this switch has six terminals whereas the original switch had only four terminals. When fitting the new switch, the extra two terminals, numbers "6" and "7", are not used – the remaining four terminals being connected up in the same manner as the original switch.

Wiring Connections when fitting PRI/2 – 34095 in place of PRI/1 – 34088

(As used with A.C. lighting-ignition set RM12 fitted to Triumph 5TAC motor cycles 1952/53, frame numbers 33868 – 35334 inclusive).

This 14-Terminal Ignition Switch, PRI/2 34095, is an authorised replacement for the 9-Terminal Ignition Switch, PRI/1 34088, originally fitted to the above motor cycles. Terminals 3 – 14 and 2 – 6 – 8 on the new switch are linked. External connections must be made as follows:

Cable Colour	Terminal on Old Switch	Terminal on New Switch
Green	2	2
White	10	3
Grey (Slate)	3	7
Red	4	11
Light Blue	6	13
Purple	1	15

Fitting Model PRI/2 – 34093 Service Replacement Switch

(As used with A.C. lighting-ignition sets RM13 and RM14).

General Servicing Information

Single-Cylinder Machines

The free end of the link shown attached to Terminal 6 must be connected to Terminal 15.

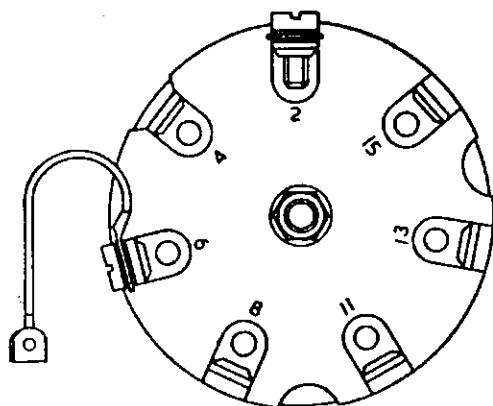

Multi-Cylinder Machines

The free end of the link shown attached to Terminal 6 must be connected to Terminal 8.

Fitting Model PRS6-34087 to Triumph Series "A" Machines

Remove the link connected between terminals "4" and "6" before fitting to a Triumph Series "A" machine.

Velocette Scooter 1961 — Alternator Wiring Connections

All Velocette scooters have the alternator cables connected Green/Yellow to Green/Black; Green/Black to Green/Yellow, to give a continuous maximum charging rate. This is normal procedure and is carried out on the production line at Veloce Ltd.

METHODS OF ADJUSTING THE DAYTIME CHARGE RATE ON RADIO-EQUIPPED MOTOR CYCLES

Six-volt battery charging requirements of motor cycles are normally met by fitting an alternator (or a dynamo) having a maximum output of some 9½ to 10½ amperes. If, in addition to the usual electrical equipment, radio communication apparatus is fitted, some five or seven extra amperes are required to operate the receiver and up to twenty-one to operate the transmitter. The receiver often represents a constant running load on machines used for road patrol duties.

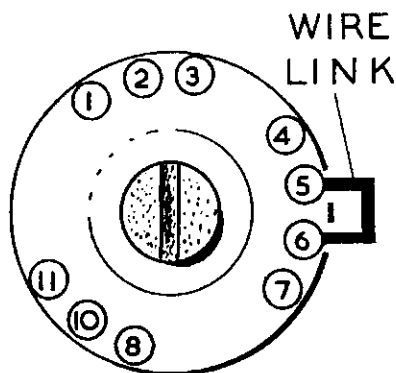

Fig. 44

The running conditions of radio equipped motor cycles vary from high-speed long-distance daylight patrol work to slow-running localised duties involving long periods of night parking. Conditions of the first kind call for a small trickle charge while those of the second demand the highest possible boost charge whenever the engine is running. A high degree of charge-rate flexibility is therefore essential if the generator output is to match all service needs and thus ensure satisfactory battery performance and life. LUCAS alternators have this flexibility. They are designed to provide five alternative daytime charge-rates – the most suitable being selected by interchanging certain external connections. It should be noted that regardless of the charge-rate selected, the maximum output is always developed in the lighting switch position "Head".

The adjustments are simple to make but the responsibility for making them should rest with the Maintenance Personnel who, being familiar with the running conditions and the state of the batteries on machines in their care, are best placed to judge when modifications to the charge-rates are necessary. In the event of doubt, however, advice should immediately be sought from the world-wide Lucas Service Organisation.

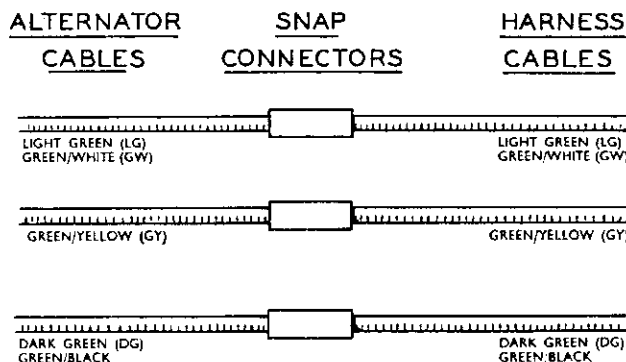

Fig. 45

The alternator stator carries three pairs of series-connected coils. The output in the lighting switch positions "Off" and "Pilot" is adjusted by varying the number of coils connected across the rectifier and battery and either shorting or open-circuiting any remaining coils, according to the tabulated instructions opposite. The number of coils connected across the rectifier and battery can be varied by

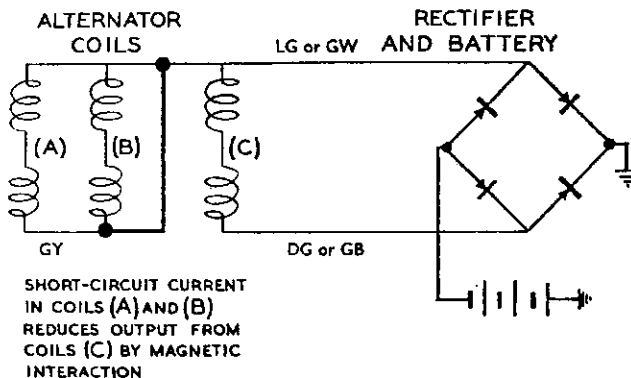

Fig. 46

General Servicing Information

transposing connections between the alternator and the wiring harness at the snap-connectors. Any remaining coils can be shorted or open-circuited by inserting or withdrawing the wire link shown connecting the lighting switch terminals "5" and "6" in Fig. 44.

How to make an adjustment

If the state of charge of a battery appears consistently to indicate that the daytime charge-rate is either too high or too low, proceed as follows:

- (i) Examine the alternator cables where they join the wiring harness and make a note of the colour of each cable as it enters and leaves its snap-connector.

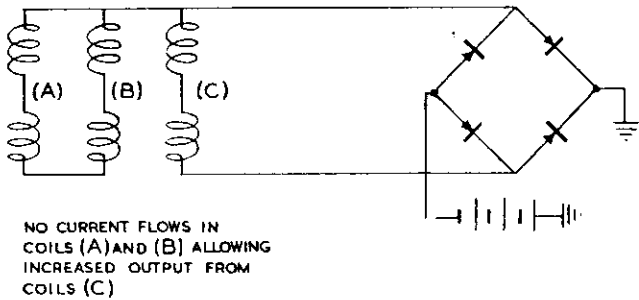

Fig. 47

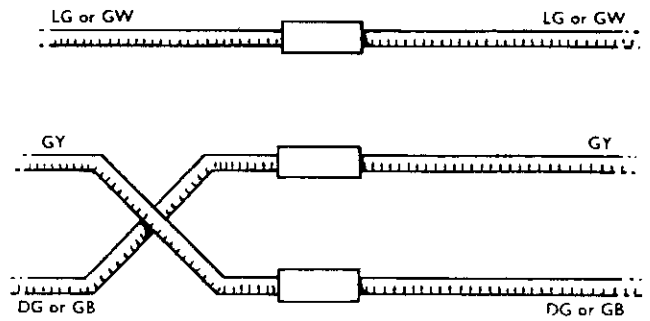

Fig. 48

- (ii) Examine the lighting switch and see if terminals "5" and "6" are linked.
- (iii) Refer to the table below and note that the five alternative methods of connection are given in columns 1 and 2 - line 1 producing the minimum output and line 5 the maximum.

(Some idea of the effect of each method can be gained by reference to columns 3 and 4. Similar effects can be obtained with other alternators in the Lucas range. Reference to the theoretical circuit of each method is made in column 5).

Alternator Connections 1	Lighting Switch Terminals '5' and '6' 2	Model RM14 Output in amperes at:		Schematic Diagram 5
		2,000 r.p.m. 3	5,000 r.p.m. 4	
1 As Fig. 45	Linked	2.4 - 2.9	2.75 - 3.25	Fig. 46
2 As Fig. 45	Not linked	3.75 - 4.25	4.5 - 5.0	Fig. 47
3 As Fig. 48	Linked	5.25 - 5.75	6.25 - 6.75	Fig. 49
4 As Fig. 48	Not linked	6.5 - 7.0	7.5 - 8.0	Fig. 50
5 As Fig. 51	Not linked	8.5 - 9.0	9.5 - 10.0	Fig. 52

NOTE

The output of alternators connected as in Figs. 46 and 49 increases in the switch positions "Pilot" and "Head". When connected as in Figs. 47 and 50, an increase occurs only in the switch position "Head". When connected as in Fig. 52 maximum output is developed in all positions of the switch.

This latter method of connection is recommended for any small capacity motor cycle carrying a radio receiver. Even though the receiver be of low power and limited range, it does represent a steady additional drain on the battery - a drain to be balanced from the output of a single small alternator. If the amount of night riding is considerable, it may also be necessary to arrange for systematic recharging from a separate supply.

Disconnect at the snap connectors the PURPLE, GREEN and YELLOW cables, but leave the BLUE cable connected for ignition purposes. The above readings should be obtained from a satisfactory alternator.

General Servicing Information

(iv) Identify the method of connection used on the machine by comparing it with those given in columns 1 and 2, and reconnect the alternator and switch to obtain the next higher or lower charge-rate, as required.

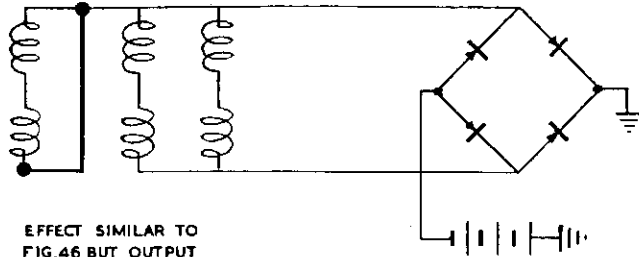

Fig. 49

If, after a representative trial period, the alternator output still does not match the running conditions, repeat the above procedure.

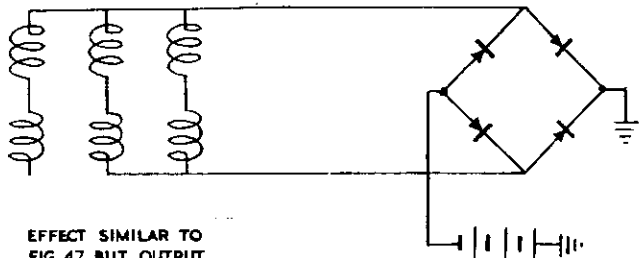

Fig. 50

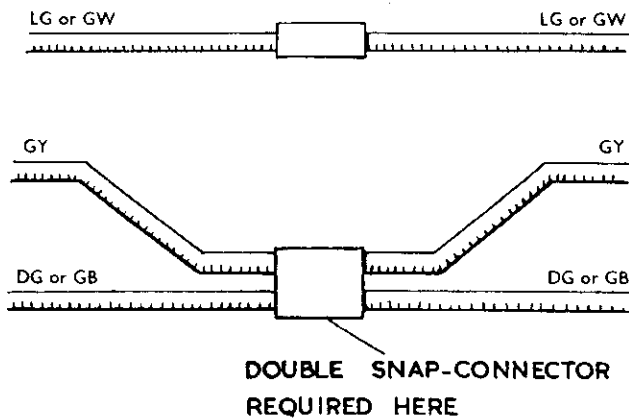

Fig. 51

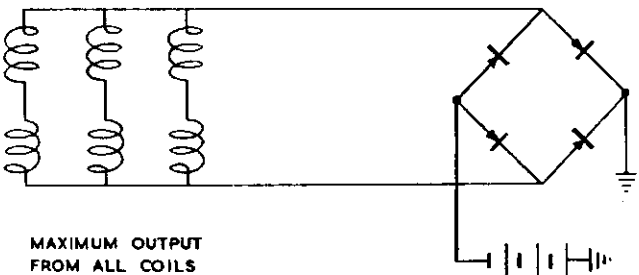

Fig. 52

THE DOUBLE GENERATOR CHARGING SYSTEM

Some machines intended to carry radio communication equipment are fitted by the motor cycle manufacturers with the LUCAS Double Generator System in which the combined outputs of an alternator and d.c. generator are fed into a 6-volt battery. A typical wiring diagram for a coil ignition machine fitted with this system is given in Fig. 53 and that for a magneto ignition machine in Fig. 54.

The system comprises a crankcase-located Model RM13, 14 or 15 alternator with its magnet rotor carried on and driven by an extension to the crankshaft, and a Model E3L generator mounted either separately and driven at engine speed or forming part of a standard magdyno.

In general, the normal electrical demands are met by the rectified output of the alternator whilst any additional radio loading is met by the generator. The alternator output is controlled by the lighting switch in the usual manner and, depending on the alternator and switch connections, increases automatically in the switch positions "Pilot" and "Head". The generator output is under compensated voltage control.

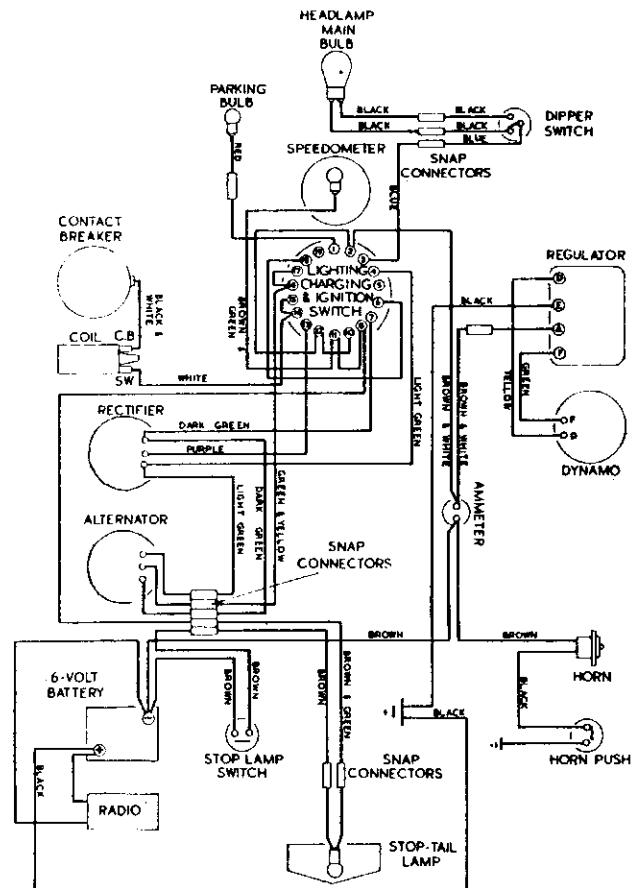

Fig. 53 Alternator/D.C. generator and coil ignition

Providing the generators are driven above their minimum "balancing speeds" (when charge and discharge currents are equal) the battery charging current is additional to the load current and varies from a trickle charge of some 1.5 - 2.5 amperes into charged batteries to 3.5 -

General Servicing Information

5-0 amperes into discharged batteries. These combined charging rates are substantially constant for all sizes of battery and, as mentioned above, lamp switching and compensated voltage control cause the output from the generators to increase automatically and balance the load as each item of equipment is switched on.

On leaving the motor cycle manufacturers, the alternator terminal connections are arranged as in Fig. 44 and the lighting switch terminals "5" and "6" are not linked. However, the charge rate can be varied to suit individual requirements as previously described.

High-Output Alternators

Unless special reasons exist for retaining model E3L generator and its associated control box, as in certain export orders, motor cycles requiring additional electrical generating capacity are now fitted with a single high-output alternator and rectifier.

Models 63SA and 88SA Switches

These small switches each comprise two separate lighting and ignition portions having, together, virtually the same terminal numbering as the larger combined ignition and lighting switch model PRS8 shown in the wiring diagrams in Figs. 53 and 54. Terminal connections are made by crimping or soldering.

Adjustment of Alternator Output

Removal of the wire link shown in Fig. 44 is applicable only to model PRS8 switches, since, with models 63SA and 88SA, the cable from terminal "18" shown in Fig. 53 is taken to terminal "5" and not to terminal "6". The same increase in alternator output can however be obtained with switches 63SA and 88SA by cutting and taping-up the cable from terminal "4". About 1½" should be left attached to the switch to allow for any future re-connection.

Note

Terminal "4" (or, in switch models U39 and 41SA, No. "7") is only used with 3-rate charging systems, i.e., where an increase in alternator output occurs in the Parking Light position. When used, terminal "4" (or "7", U39 and 41SA) must be disconnected before attempting the wiring modifications shown in Figs. 48 and 51, should the higher outputs obtained with these latter methods of connection be required.

Cable Colours

Cables formerly coloured Light Green are now White-with-Green.

Cables formerly coloured Dark Green are now Green-with-Black.

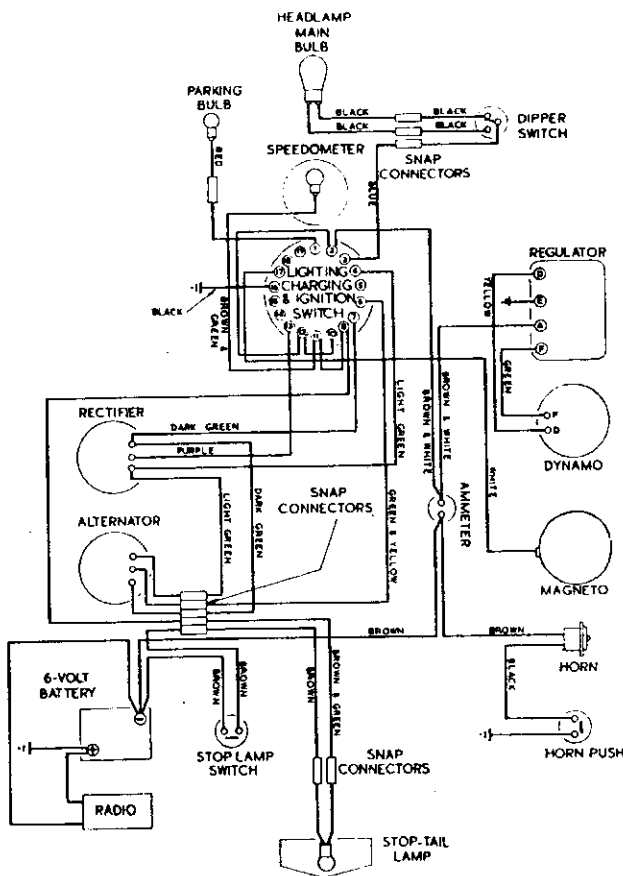
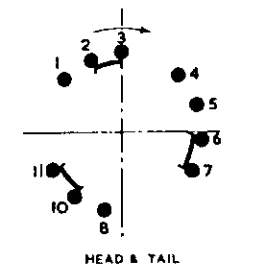
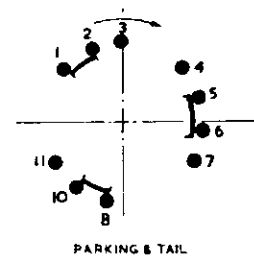
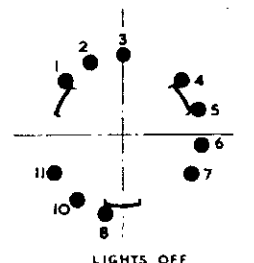

Fig. 54 Alternator/D.C. Generator and Magneto Ignition

LIGHTING PORTION VIEWED FROM FRONT OF SWITCH



IGNITION PORTION VIEWED FROM BACK OF SWITCH

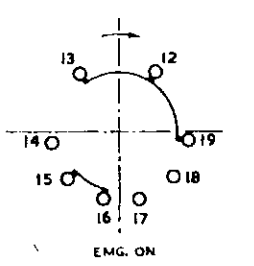
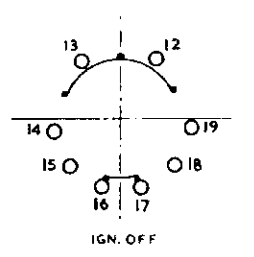
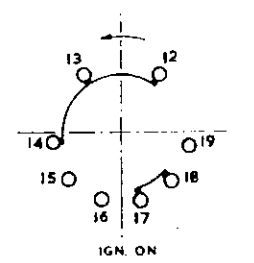

Fig. 55 Internal switch connections of model PRS8 Switch. (Applicable also to models 63SA and 88SA)

General Servicing Information

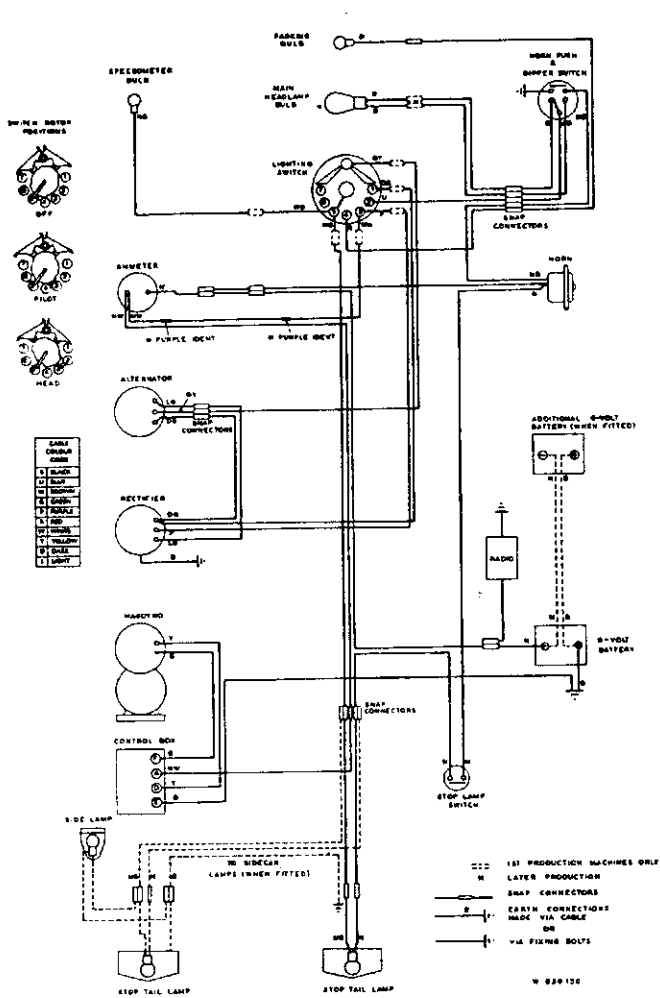

Fig. 56 Double Generator installation with Alternator, Magdyno and, either model U39 or 41SA Lighting Switch. (Note: Cable LG connected to terminal "7" on 3-rate charging systems to give lowest output) (see Fig. 46)

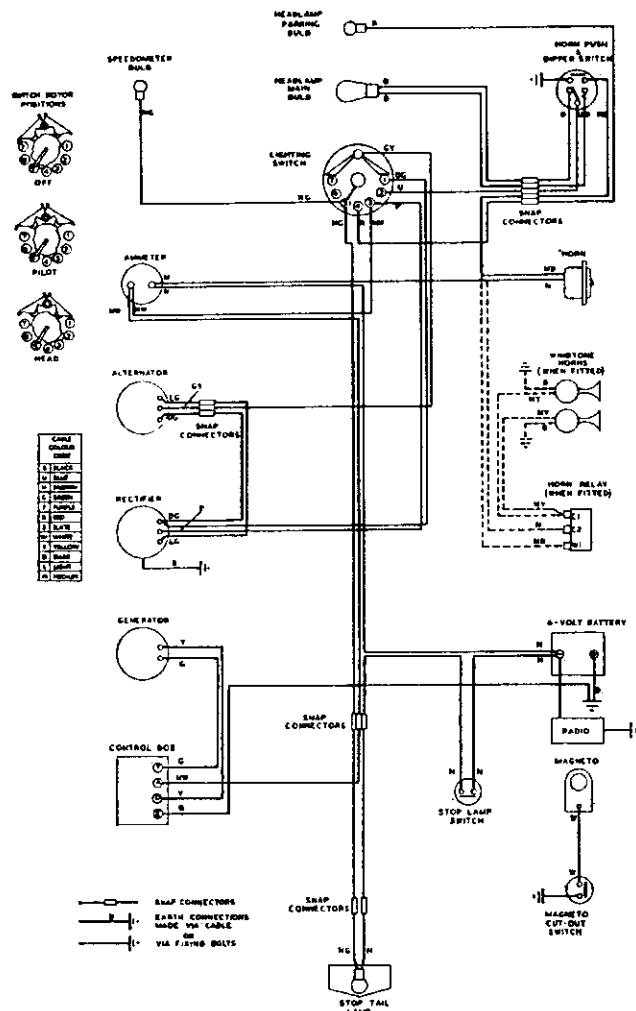

Fig. 57 Double Generator installation with Alternator, D.C. generator, Magneto and, either Model U39 or 41SA Lighting Switch. Also, alternative connections for Twin Windtone Horns and associated relay (suitable only on double generator machines)

NOMINAL OUTPUT OF MODELS RM13, RM13/15, RM15, AND 5AF ALTERNATORS

Alternator Connections 1	Lighting Switch PRS8 Terminals '5' and '6'* 2	Alternator Output (Rectified) in amperes at:								Schematic Diagram 5
		2,000 r.p.m. 3				5,000 r.p.m. 4				
		RM13	RM13/15 5AF (6-volt)	5AF (12-volt)	RM15	RM13	RM13/15 5AF (6-volt)	5AF (12-volt)	RM15	
1 As Fig. 45	Linked	1.75-2.0	2.25-2.5	1.25-1.5	2.25-2.5	2.75-3.25	2.75-3.25	2.5-3.0	3.0-3.5	Fig. 46
2 As Fig. 45	Not linked	3.0-3.25	3.25-3.5	2.0-2.25	3.75-4.0	4.25-4.75	4.5-5.0	3.75-4.25	4.75-5.25	Fig. 47
3 As Fig. 48	Linked	3.25-3.5	4.5-4.75	3.0-3.25	5.0-5.25	5.75-6.25	6.0-6.5	5.25-5.75	6.0-6.5	Fig. 49
4 As Fig. 48	Not linked	5.25-5.5	5.75-6.0	3.75-4.0	6.25-6.5	7.0-7.5	7.5-8.0	6.5-7.0	7.5-8.0	Fig. 50
5 As Fig. 51	Not linked	7.0-7.25	7.75-8.0	5.0-5.25	8.25-8.5	9.0-9.5	9.5-10.0	8.0-8.5	9.5-10.0	Fig. 52†

*For U39, 41SA, 63SA and 88SA equivalents, see page 26 and Fig. 56 caption.

†The connections shown in Fig. 52 are also obtained on operating the Maximum Charge Rate Switch fitted to certain single-alternator motor cycles equipped with two-way radio. To avoid overcharging, such switches must only be operated with the radio load connected.

General Servicing Information

THE CONVERSION OF EXISTING 6-VOLT MOTOR CYCLES TO 12-VOLT ZENER DIODE CONTROLLED OPERATION

NEW EQUIPMENT REQUIRED

When converting a LUCAS motor cycle alternator circuit from 6-volt to 12-volt Zener Diode controlled operation the electrical units which must be considered are: battery, Zener Diode and its associated heat-sink, rectifier, ignition coil, distributor (or contact breaker unit), lighting equipment, and any extra electrical accessories that may be fitted. Each of these units is considered separately below.

Battery

12-volt motor cycle batteries are available but, another method of obtaining a 12-volt supply is to put another 6-volt battery in series with the existing one. Providing the two batteries are of the same type and capacity, and the old one is in a charged and healthy condition, this arrangement will function satisfactorily. The lowest suitable battery capacity is in the region of six or seven ampere-hours. Two batteries, model MK9E/2, connected in series would give a 12-volt capacity of 7AH. Two of these batteries occupy approximately the same space as one PU7E battery.

Two ML9E batteries could be used. These have a capacity of 12 ampere-hours at the 10-hour rate, but as they are larger the problem of accommodating them on the motor cycle will be greater. For sidecar use, one of the smaller car batteries such as model BHN5A/7/8 could be installed in the sidecar boot.

Battery Model	Voltage per Unit	Ampere-Hour Capacity (10-Hour Rate)	Dimensions in Inches		
			Length	Width	Height
MK9E/2	6	7	4 $\frac{1}{2}$	1 $\frac{1}{2}$	5
ML9E	6	12	4 $\frac{1}{2}$	2 $\frac{3}{8}$	5 $\frac{3}{8}$
BHN5A/7/8	12	18	7 $\frac{7}{8}$	5 $\frac{1}{2}$	7 $\frac{7}{8}$
PU5A	12	8	5 $\frac{5}{8}$	3 $\frac{1}{4}$	5 $\frac{5}{8}$

Zener Diode and heat sink

A stud-mounted Zener diode, Part Number 49345 will be required. The diode must be bolted to a heat sink (cooling fin) to prevent its working temperature from rising above the designed operating range. The heat sink must be made of copper or aluminium sheet of approximately 16 S.W.G. ($\frac{1}{16}$ " thick), have an area of 25 square inches, and be as square as space limitations permit. In practice, it is found that an area of 6" x 4 $\frac{1}{4}$ " (as shown in Fig. 58) can most readily be accommodated. The diode must be mounted as near to the centre of the heat sink as possible. Care must be taken to see that the metal of the heat sink is *flat around the diode fixing hole to ensure maximum heat conduction from the diode. The diode fixing nut should be tightened to a torque between 24 and 28 lbf in. Care should be taken not to exceed this figure otherwise the fixing stud may shear.

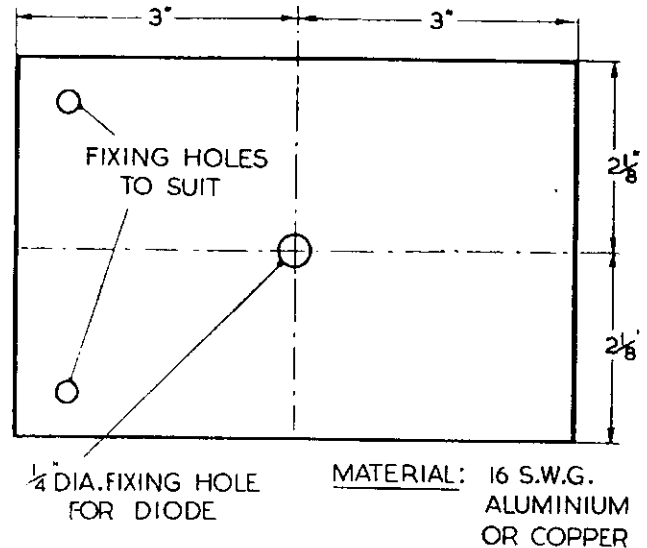

Fig. 58 Outline and dimensions of typical heat sink for Zener Diode

Rectifier

Over the years several rectifiers have been used on alternator equipped machines but only the latest design, Part No. 49072, is definitely suitable for use with Zener diode charge control. This is a black silicon bridge unit, introduced in April 1962, which functions equally well in either 6 or 12-volt circuits. If the existing rectifier is a square selenium unit, Part No. 47132, or one of the earlier selenium types, it should be removed and Part No. 49072 fitted. Lucar terminals, Part No. 54942078, and insulating covers, Part No. 54190042, will be required for connecting up the new rectifier.

Ignition Coil

The existing ignition coil will be a 6-volt unit. This must be replaced by a 12-volt unit.

Replace model MA6 with MA12, Part No. 45101, or model LA6 with LA12, Part No. 45141.

Capacitor

The capacitor fitted in contact breaker unit model 18D1 and distributor model 18D2 is unsuitable for use with 12-volt ignition coils. It must therefore be removed and a new capacitor, Part No. 54441582, fitted externally.

All other capacitors are suitable for 12-volt operation.

Horn

Several 12-volt horns are available, including a 12-volt version of the original horn fitted (probably high frequency horn model 8H), the more powerful high frequency model 6H, and the car type windtone horn, model 9H, which can be used either singly, or as a matched low and high note pair. If a pair of windtone horns is fitted, it will be necessary to use a relay to limit the current passing through the horn button contacts.

*Ensure that the washer is fitted immediately under the nut and not between the diode and heat sink. All burrs must be removed to ensure metal-to-metal contact.

General Servicing Information

Zener Diode

On coil ignition motorcycles the Lucar terminal of the diode should be connected to the "SW" or "-ve" terminal of the ignition coil. On magneto ignition motorcycles this connection should be made to the "-ve" terminal of the battery.

On magneto ignition motorcycles equipped with ammeters, it is necessary to connect the diode to the ammeter terminal which carries the Brown-with-White cable(s) to enable the ammeter to indicate charging.

Note:

The method of fitting Lucar connectors to cables is shown stage-by-stage on page 21.

Rectifier

The terminals of the silicon bridge rectifier have the same arrangement as the earlier selenium types, the connections should therefore be as shown in Fig. 60.

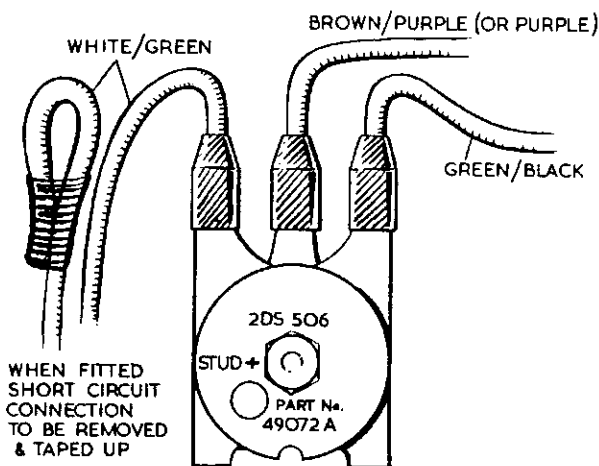

Fig. 60 Rectifier connections with White/Green "short circuit" cable disconnected and taped up

If the original circuit includes a White/Green cable (or equivalent) connecting a rectifier outer terminal to the lighting switch, it will be necessary in most instances to disconnect one end of this cable and tape it up, as shown in Fig. 60.

Note:

This connection, often used with magneto ignition machines, served to limit battery charging currents during daylight riding by shorting out certain of the alternator coils in the lighting switch position "Off". Whenever possible, we have indicated in the *equipment lists, tabulated for individual models, on pages 5-15, whether or not the White/Green cable is to be disconnected.

When fitting the rectifier to the machine remember the bolt acts as the "+ve" connection to earth.

Ignition Coil

The terminal arrangement of the replacement coil is identical to the original coil. The White cable should therefore be connected to the "SW" or "-ve" terminal, and the Black/White cable to the "CB" or "+ve" terminal.

Capacitor (When applicable; see page 28)

Connect the capacitor either to the L.T. terminal of the contact breaker unit (or distributor), or to the ignition coil terminal "CB" (or "+"). The body of the capacitor must be in good electrical contact with earth.

Horn

Connect in the same manner as the original, or as directed in the boxing leaflet supplied with the new horn(s).

Alternator

As the Zener diode can only deal with 5 amperes, it is necessary to retain some form of alternator coil switching in the headlamp position.

With coil ignition machines four of the six alternator coils should be permanently connected across the rectifier and the remaining two coils brought into circuit when the headlamp is switched on. As shown in Fig. 61a, this is done by transposing two of the three alternator-to-wiring-harness connections (Green/Yellow and Green/Black) at the snap-connectors.

Note:

In two-colour cables, the first named is the main colour and the second the tracer. The identifying colours at present used have been chosen for their permanency — they do not discolour with age and normal service. For reference, we give below the four transitional colour coding schemes used since 3-wire motorcycle alternators were introduced some twelve years ago.

	1	2
	Light Green	Light Green
	Mid Green	Green-with-Yellow
	Dark Green	Dark Green
	3	4
	Green-with-White	White-with-Green
	Green-with-Yellow	Green-with-Yellow
	Green-with-Black	Green-with-Black

With magneto equipped machines there is no ignition coil load so the output from four alternator coils would be too high for the diode to control. Thus two only of the alternator coils must be permanently connected across the rectifier, with the remaining four coils being brought into circuit by the lighting switch. This is done by connecting the alternator output cables colour to colour, as shown in Fig. 61 (b).

*This equipment list, Publication No. 2380A, is available on request to Motor Cycle Section — Service Dept., J. Lucas (Sales & Service) Ltd., Great Hampton Street, Birmingham, 18.

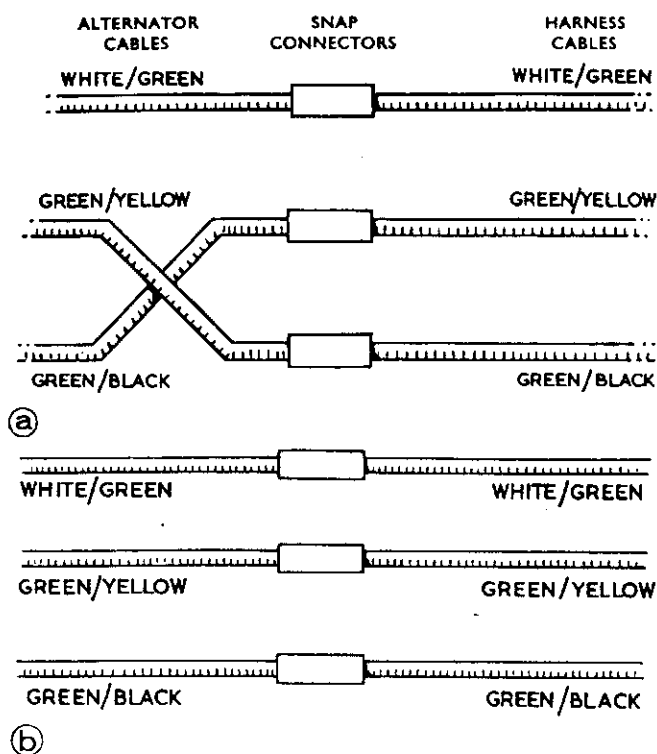

Fig. 61 Alternator to wiring harness connections (a) for coil ignition and (b) for magneto ignition machines

MAINTENANCE

Providing the diode and its heat sink are kept clean, to ensure maximum efficiency, no maintenance will be necessary. Maintenance of the other items of equipment listed in the conversion is dealt with in Booklet No. 2644 which will be supplied upon request.

SPECIAL ALTERNATOR STATOR WINDINGS FOR AMERICAN TERRITORIES

Lucas alternators are designed to develop current outputs to meet differing conditions of machine usage and electrical loading. Thus "high" and "low" output versions of each standard alternator are manufactured, and all are covered in the following tables. In addition, mention must be made of the special "low-low" output alternators fitted to certain motor cycles exported to American territories whose stator windings are designed to obviate over-charging under "Turnpike" riding conditions. Stators produced for this duty are stamped with one of the following Part Numbers: 47171 or 47183, and were fitted on machines up to 1963. These Part Numbers can be seen on removal of the primary chain case. If your machine is equipped with one of these alternators, you must reconnect the cables as shown in Fig. 61(a) and, if fitted, disconnect the short circuit connection, as shown in Fig. 60.

Right-hand dip headlamps

On machines fitted with right-hand dip headlamps (marked "LEFT HAND DRIVE"), replace the bulb with Lucas No. 355, 12-volt 42/36 watt.

1966 TRIUMPH T20SS

How to modify the wiring for trials and scrambles work

This machine is equipped with an alternator having a stator wound with three pairs of coils. The output from the alternator, controlled by the lighting switch, depends on how these sets of coils are interconnected. A higher output is given when the headlamp is switched on and a lower output when the parking light only is used. The smaller output is also given in the switch "OFF" position for feeding the ignition coil, stop-light and battery.

However, if the lighting equipment should be removed, for trials and scrambles work, even less current will be required from the alternator, in fact, just enough to supply the ignition coil and to trickle-charge the battery. To meet this latter condition, provision has been made to enable the owner to make a simple modification to one of the cable harness connections. The modification consists of withdrawing a cable from one snap-connector and inserting it into another, as explained below.

On inspection, it will be seen that three cables are brought out from the alternator, and these are coloured White-with-Green (terminating in a double snap-connector), Green-with-Yellow and Green-with-Black (terminating in a triple snap-connector). At the snap-connectors these cables are joined, colour for colour, to three similar cables from the harness loom. In addition, a fourth cable, coloured Green-with-White, is brought out from the loom.

For running with lighting equipment fitted, this fourth cable GW must be inserted in the unoccupied portion of the triple snap-connector (see Fig. 62), but, whenever the lighting equipment is removed, cable GW must be withdrawn and plugged into the unoccupied portion of the double snap-connector. This will serve to reduce the alternator output to the correct value, when the lighting switch is in the "OFF" position, as the alternator control coils are in effect short-circuited. Failure to carry out this modification, when running without lighting equipment, could result in an over-charged battery, with possible damage to the machine.

Note

The three portions of the triple snap-connector are electrically separate, but the two portions of the double connector are electrically common.

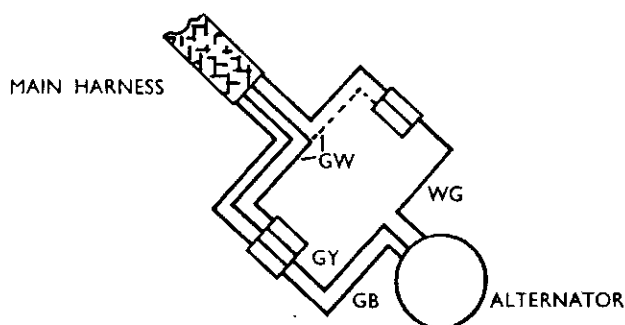

Fig. 62

General Servicing Information

RM12 ALTERNATOR — CONVERTING SERIES "B" MACHINES TO SERIES "C" INCLUDES LATEST IMPROVEMENTS FOR "EMERGENCY" RUNNING

As a direct result of service experience with the new "six lead" RM12 alternator it seemed desirable that provision should be made for continuous operation in the "EMG" switch position. A revision to the equipment was therefore made.

It permits the continuous use of the machine in the "EMG" switch position with full engine performance. Previously it was not possible to do this because the high speed output from the alternator series "B" was too great. This latest improvement protects the electrical circuits from accidental misuse of the "EMG" switch and also helps where riders wish to use the machine temporarily without a battery for "trials" or other sporting events. It should be pointed out that the battery cannot be charged in the "EMG" switch position and, without a battery, it is not possible to use the lighting or horn.

N.B.: Where the equipment is run temporarily without a battery ALWAYS connect the brown battery lead in the harness to earth.

We supply complete kits (Part No. 047504) to our Service Depots so that they can arrange to convert all the machines now in service.

FITTING INSTRUCTIONS

There are four stages in the procedure:

1. Fit new rotor.
2. Fit new resistor and bracket and resistor leads.
3. Modify the alternator feed cables.
4. Fit new switches and switch harness.

Fitting New Rotor

- (a) Remove exhaust pipe from L.H. side of motor cycle (alternator side).
- (b) Remove foot rest.
- (c) Remove foot brake pedal — by removing brake pedal retaining nut and sliding the brake pedal off the pivot.
- (d) Take off the chain case — remove screws around case and gently ease off the cover, taking care not to damage paper gasket. (If gasket is damaged a new one must be fitted).

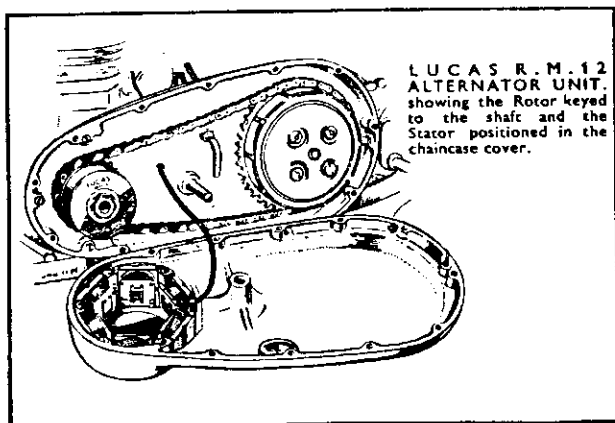

Fig. 63

- (e) Remove rotor fixing bolt — engage top gear and hold back wheel while unscrewing bolt — this prevents the engine shaft turning.
- (f) Remove rotor — this is a tight fit on the shaft, and must be gently eased off with a large sprocket drawer or two suitable levers.
- (g) Fit new rotor.
Reverse above procedure for re-assembly — remember to bend up the locking washer tag against rotor fixing bolt.
- (h) Replace chain case cover — tighten screws evenly and refill with half-pint of SAE 20 engine oil.
- (i) Finally replace the foot rest and brake pedal. Smear the brake pivot pin with medium grease and tighten the lock nut securely.

Fitting New Resistor

- (a) Run the sleeved resistor cables from the nacelle over the top of the main harness to the resistor mounting bracket under the saddle.
- (b) Unbolt the rectifier mounting bracket and turn it over (see illustration), take care not to lose the distance piece under the front fixing bolt.
- (c) Connect red and blue leads to resistor and fit in position shown.
- (d) Make sure resistor has a good earth by removing any enamel under the fixing bolt.

Reconnecting Alternator Leads

- (a) Remove both green and both red leads from the connector block under the saddle. Using the double snap connector provided, connect the green and the red lead from the alternator to the green lead in the main harness. Tape up the red lead in the main harness which is no longer required. (See inset illustration, (Fig. 64.)

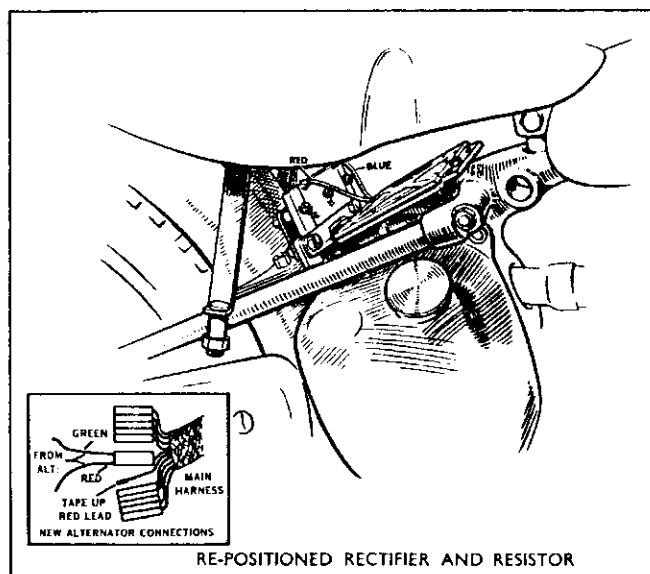

Fig. 64

General Servicing Information

Fitting New Switches and Switch Harness

- (a) Disconnect negative battery lead.
- (b) Remove light unit.
- (c) Disconnect speedometer drive cable and bulb holder then remove speedometer from the nacelle.
- (d) Remove the clip holding the cable harness to left side fork leg.
- (e) Remove the existing switches from nacelle, unscrew lock nuts and pull switches forward, clear of the nacelle.
- (f) Disconnect the main harness leads from the two five-way connectors.
- (g) Disconnect blue lead from lighting switch (terminal 3).
- (h) Disconnect orange lead from ammeter.
- (i) Disconnect brown leads from horn and ammeter.
- (j) Cut off black lead going to lighting switch close to the earthing-eyelet which fastens under the speedometer securing bolt.
- (k) The two switches can now be completely removed.
- (l) Connect new switch harness to main harness – (colour to colour); tape up red lead in main harness – no longer required.
- (m) Connect blue lead from dip switch to terminal (3) on lighting switch.
- (n) Connect maroon lead from terminal (1) on lighting switch to speedometer illumination bulb holder (remove holder from the old switch harness).
- (o) Connect brown leads *eyelet* to ammeter, left hand terminal looking into the nacelle.
- (p) Connect loose end of brown lead to horn.
- (q) Connect orange lead to other ammeter terminal.
- (r) Connect resistor red and blue leads to the appropriate terminals on the snap connector block.
- (s) Fit new switches in nacelle.
- (t) Clip harness to left hand fork.
- (u) Refit speedometer in nacelle, and connect up speedometer drive; make sure that the black earth lead eyelet is clamped in position under the fixing bolt.
- (v) Replace speedometer bulb holder in its housing.
- (w) Make sure that no switch wires or terminals are touching the speedometer or fixing bracket.
- (x) Replace light unit.

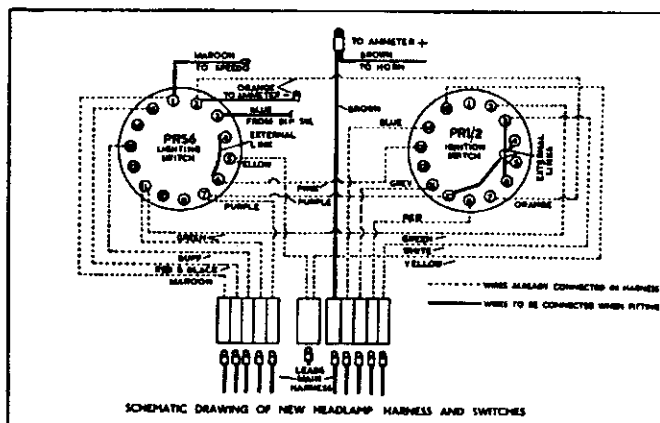

Fig. 65

- (y) Reconnect the battery lead and test the circuit in each switch position.

TEST EQUIPMENT REQUIRED

In order to carry out our recommended service tests, the following instruments are required:

1. A.C. voltmeter, scaled 0 – 20 volts (moving coil).
2. D.C. voltmeter, scaled 0 – 20 volts (moving coil).
3. D.C. ammeter, scaled 0 – 20 amps. (moving coil).
4. A 1 ohm resistor (non-inductively wound on a hollow asbestos former).
5. A 12 volt battery, 50 ampere-hour (approximately).

High grade moving coil meters should be used with a clear scale, so that the meter can be read accurately to a quarter of a volt, or ampere.

The 1 ohm (non-inductive) resistor should be capable of carrying approximately 10 amps. without overheating.

HOW TO MAKE UP A ONE OHM RESISTOR

The 1 ohm resistor must be accurate otherwise correct voltage (or current) values will not be obtained.

A suitable resistor can be made from 4 yards 18 S.W.G. (.048" dia.) NICHROME wire together with two flexible leads and suitable crocodile clips, see Fig. 66.

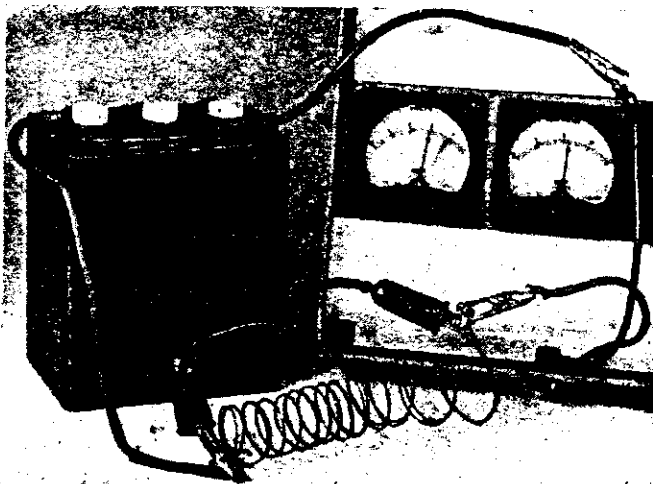

Fig. 66

To Calibrate

Bend the wire into two equal parts.

- (a) Fix a heavy gauge flexible lead to centre bend of the wire, and connect this lead to the positive terminal of a 6-volt battery.
- (b) Connect a voltmeter across the battery terminals.
- (c) Connect an ammeter to the battery negative post.
- (d) Take a lead from the other terminal of the ammeter, connect a crocodile clip to it, and connect to the free ends of the wire (which should be twisted together).
- (e) Move the clip along the wire, making contact with both wires until the discharge reading on the ammeter exactly equals the number of volts shown on the voltmeter. The resistance is then 1 ohm.
- (f) Cut the wire at this point, twist the two ends together and fix a second heavy gauge flexible lead.
- (g) Wind the wire on to a hollow asbestos former 2" dia. (approximately).

General Servicing Information

The foregoing gives a general description of the test equipment required and it would perhaps be helpful to mention here that there are a number of compact portable test sets on the market suitable for this class of work. The manufacturers of this equipment will undoubtedly be pleased to supply you with all relevant information upon request.

If any difficulty should arise however, or should you be undecided as to the capabilities of a particular set we shall on receipt of a post card be very pleased to help and advise in your choice of the correct equipment.

SWITCH CONTINUITY TESTS

A 36-watt lighting bulb with leads attached to it can be used for checking the continuity of lighting and ignition switches. Internal connection diagrams for the various types of switches used with the alternator systems are shown on the wiring diagrams contained in this book.

Switches can be checked without the need for removing them from the machine, and if advantage is taken of the fact that harness connections are made to snap connectors external wiring and switch continuity can be established at the same time. Alternatively, remove the switches from the machine and bench test individually.

A 6-volt or 12-volt supply can be used for testing to ensure that switch contacts are working correctly under load. A fault such as a high resistance connection may not be apparent if the switch is not tested with a load current approximately that which it normally carries during use in service.

TESTING PROCEDURE

Until completely conversant with alternator sets it is advisable to carry out all testing progressively in the following sequence:

Test (1) Test the set overall by checking the current input to the battery. Check that battery is in a good state of charge. If battery is faulty it must be temporarily replaced with a good one before testing.

Test (2) Check the output from the individual sets of generator coils.

Test (3) Test the rectifier.

Test (4) Test wiring and continuity through switch positions.

IMPORTANT

All Lucas A.C. sets use a POSITIVE EARTH battery system, i.e., the battery POSITIVE lead is connected to the frame of the machine. Both selenium and silicon rectifiers and semi-conductor devices, if fitted, will be irreparably damaged if the battery is incorrectly connected.

FITTING A CLIPPER DIODE

To ensure maximum life and efficiency from this diode read the following instructions before attempting to fit it to a machine.

Fitting the Diode to a Heat Sink

The diode should be mounted onto a metal plate (heat-sink) made from either aluminium or copper, (the metal plate should be free of paint to allow metal-to-metal contact), the minimum dimensions of which are $\frac{1}{8}$ in. (1.58 mm.) in thickness measuring $1\frac{1}{2}$ in. x $1\frac{1}{2}$ in. (38.10 x 38.10 mm.). A $\frac{3}{16}$ in. (4.76 mm.) hole should be drilled in the centre. The plate should then be fixed to the machine

in any convenient position which allows free passage of air around the diode and plate when in motion. Do not position the unit too close to the ground as it may be subjected to dirt and water thrown up by the wheels. Ensure that the plate is properly earthed to the machine. A separate earth lead should be fitted if there is any doubt as to the plate being earthed properly through its fixing bolts.

As an alternative method, the diode could be mounted in the headlamp shell, which would in effect act as a heat-sink. But, only if the radius of the shell is such that when the diode is fitted the whole area of its base is in contact (flat onto the metal shell) with the shell. A suitable hole, $\frac{3}{16}$ in. (4.76 mm.) in diameter should be drilled near the bottom of the shell and the diode placed in position, (with any paint removed so that a metal-to-metal contact is achieved), so that the mounting stud protrudes on the outside of the shell.

CAUTION:

The Diode fixing nut must be tightened to a torque between 8 and 12 lbf in (0.092 — 0.138 Kg-m). Care should be taken when tightening as the copper (threaded) fixing stud will easily break if overstressed.

Soldering a length of Cable to the Diode Terminal

The exact length of cable required will depend on where the diode has been positioned. To solder the cable to the diode terminal a small (instrument type) soldering iron and resin cored solder must be used. Also, a thermal shunt, such as a pair of long-nosed pliers should be used, to grip the diode terminal during soldering, to prevent the possibility of damage due to excessive heating.

Connecting the Diode into Circuit

The main point to remember when connecting the diode into circuit is that it must be connected on the lamp (bulb) side of the lighting switch and *not* the alternator side. If connected to the alternator side of the switch it will be subjected to continuous full loading, with consequent reduction in service life, instead of only being loaded when the lights are switched on. This can be achieved by connecting either into the Tail-lamp feed or the wire supplying the Dipper Switch. If no Dipper Switch is used, the connection would be made directly to the Headlamp bulb feed.

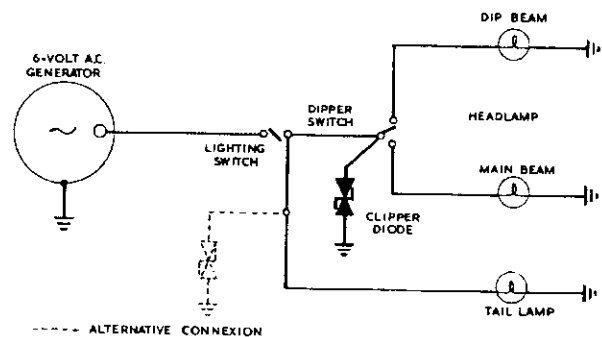
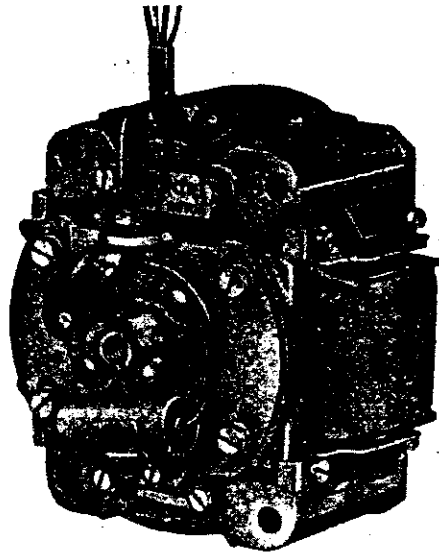

Fig. 67 Method of connecting Clipper Diode in circuit

Note: Fault Diagnosis

A faulty Clipper Diode is self-evident as premature bulb failure, when operating the dipper switch, will ensue. Before fitting a replacement check that wiring connections are clean and tight, particularly the earth cable.

TEST PROCEDURE



IA45 ALTERNATOR SET

Checking D.C. Input to Battery

TEST 1. Ammeter connected in series with main lead and battery.

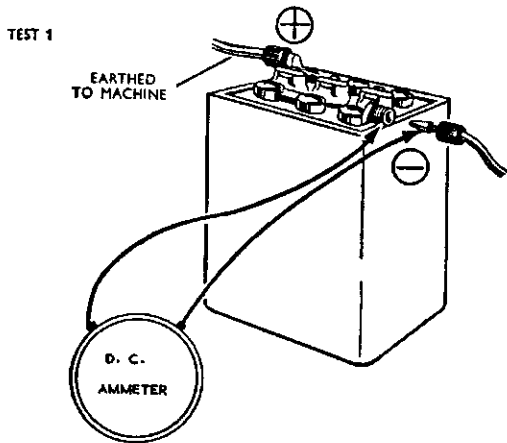

TEST 2. Disconnect main lead from battery. Connect 1 ohm resistor in place of battery. Feed ignition coil separately from battery. Turn ignition switch to IGN position.

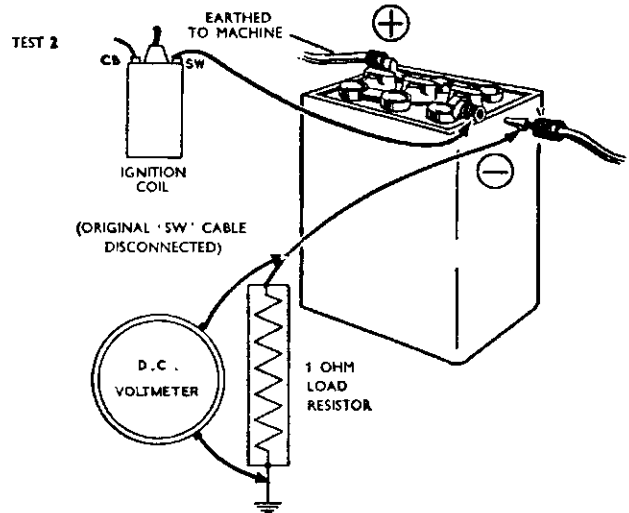

If battery is in poor condition or low state of charge use TEST 2.

Test	Switch Position	Reading Amps. at 3,000 r.p.m.
1	OFF	3.0 (min.)
	PILOT	5.0 (min.)
	HEAD	2.5 (min.)

Test	Switch Position	Reading Volts at 3,000 r.p.m.
2	OFF	4.5 (min.)
	PILOT	8.0 (min.)
	HEAD	5.5 (min.)

CONCLUSIONS FROM THESE TESTS

Test 1. If meter readings are as stated, the charging circuit and alternator are satisfactory.

No reading; check the generator.

A low reading can be caused by a faulty battery. Proceed with Test 2. If readings still low check battery with hydrometer and discharge tester. A high reading, 2 – 3 amps above values given, in the "OFF" position may be due to an open-circuit half-charge resistor, which should be checked, or to one cell of the battery being short-circuited. If Test 2 readings are satisfactory, then check the battery.

Test 2. If meter readings are lower or higher than values stated, check the generator.

No reading on meter, check the rectifier.

IMPORTANT

Inaccurate readings can be due to faulty wiring, bad connections at the snap connectors. Make a quick visual check of all connections before proceeding with the tests.

Remember it is no use carrying out Test 1 if the battery is faulty or in a low state of charge, if in doubt proceed with Test 2.

Testing the IA45 Alternator on the Machine, using an A.C. Voltmeter and 1 Ohm Load Resistor

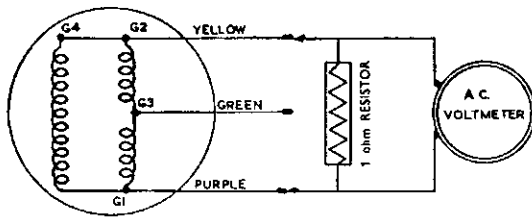

Test	Voltmeter and Resistor Connected Across	Voltmeter Reading at 4,000 – 5,000 r.p.m.
1	G1 AND G2	4.5 (min.)
2	G1 AND G3	8.5 (min.)
	G2 AND G3	8.5 (min.)

Test	Individual Coil Check (disconnect G2 and G4)	
3	G1 AND G4	2.3 (min.)
	G1 AND G2	2.3 (min.)

Test	NO READING SHOULD BE OBTAINED WITH VOLTMETER CONNECTED ACROSS ANY ONE LEAD AND THE GENERATOR STATOR (EARTH)
4	

Disconnect at the snap connectors the Purple, Green, and Yellow cables, but leave the Blue cable connected for ignition purposes. The above readings should be obtained from a satisfactory alternator.

CONCLUSIONS FROM THESE TESTS

- (a) If a reading is obtained in Test 4, a coil or cable is earthed. Check coil lead and terminal plate.
- (b) If no reading is obtained in Test 4 but very low readings in Tests 1 and 2, a short circuit across an internal connection of a coil can be suspected. Test 3 should then indicate the faulty coil. If very low readings are obtained from both coils in this test the alternator is most probably severely demagnetised.
- (c) A reading of approximately 2.5 to 3.5 volts in Test 1 will normally be obtained if the rotor has been withdrawn and replaced. Remagnetisation is required.

IMPORTANT

If the alternator voltage is excessive, do not immediately assume it is over-magnetised. First check for poor earths and for badly soldered and loose connections. A badly earthed rectifier will give the same apparent effect as an over-magnetised generator.

As snap connectors are used on the set it is quite possible that they have not been pressed firmly together and it is advisable that these are checked if voltage readings are considerably higher than the values given.

NOTE

When carrying out Test 1, and G4 is brought out as a separate cable, a temporary link should be connected between G4 and G2 on the alternator terminal plate.

Rectifier—Bench Testing

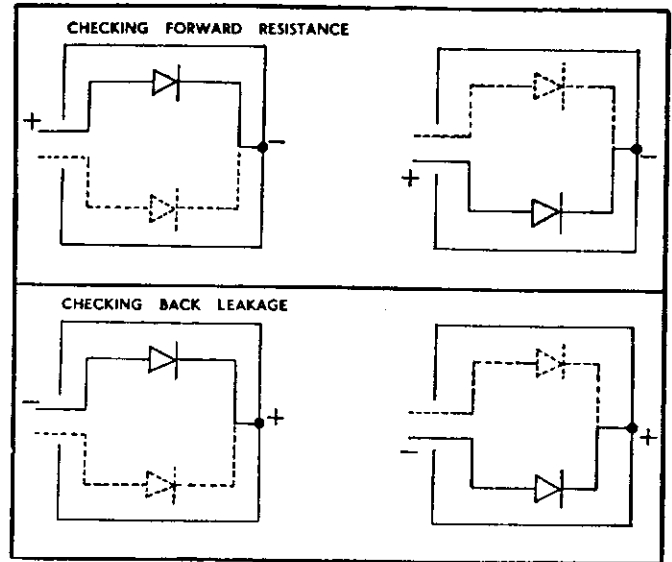
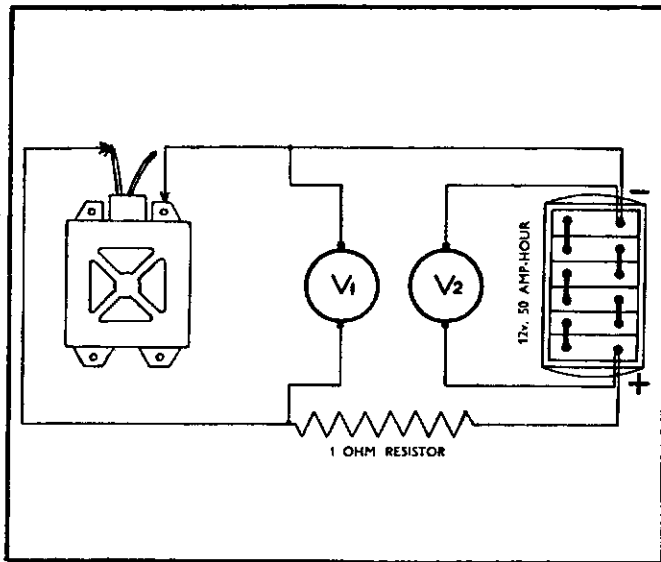

- V1 — will measure the volt drop across the rectifier cell, which should not be greater than 2.5 volts.
 V2 — must be checked when testing the rectifier cell, to make certain the supply voltage is 12 volts on load.

It is essential that the supply is kept at 12 volts for these tests.

FORWARD RESISTANCE TEST

- Test 1. Connect negative lead to rectifier case. Connect positive lead to each cable connector in turn; reading on V1 should not be greater than 2.5 volts. Keep the testing time as short as possible to avoid overheating the rectifier cell.

BACK LEAKAGE TEST

- Test 2. Connect positive test lead to case; negative test lead to each cable connector in turn. Reading on V1 should not be below 10 volts.

CONCLUSIONS FROM THESE TESTS

If the voltage reading, in Test 1, is exceeded on either rectifier cell, the unit is aged and should be replaced.

If the reading in Test 2 is well below 10 volts, on either or both cells, the rectifier is shorted internally and should be replaced.

DOUBLE BANK RECTIFIER (47094) USED WITH THE RM12 SERIES "A"

The test procedure and figures for this rectifier are as quoted in the above tests. But it will be necessary to disconnect the two leads which are connected to the rectifier fixing bolts, before testing the two units separately.

IMPORTANT

There are two types of Westinghouse rectifiers in service on LUCAS sets. The original having low voltage plates being identified by the figures 2L stamped on the case, the other which has high voltage plates being identified by the figures 12L.

The values quoted in the above tests are for the high voltage rectifiers 12L. When testing a low voltage rectifier 2L the Forward Resistance reading should be the same but the Back Leakage figure can be down to 9 volts.

Circuit Continuity through Switch Positions

TO TEST IGNITION SWITCH

1. (Connecting charging circuit to battery).
Connect red voltmeter test lead to earth.
Connect black voltmeter lead (with 1 ohm load in parallel) to single snap connector containing green cable from alternator.
Switch ignition on when battery volts should register on D.C. voltmeter.

TO TEST HALF-CHARGE SWITCH AND RESISTANCE

2. Disconnect the two cables (purple and yellow) coming from the headlamp into the snap connectors. Temporarily connect the purple cable to the single snap connectors containing green cable.
Connect black voltmeter lead (and 1 ohm load in parallel) to the yellow cable.
Leave ignition switch "ON".
With light switch off, battery volts should register on D.C. meter and zero volts with the light switch in Pilot or Head position.
3. The two remaining cables are from the rectifier which can be tested from this position by carrying out the procedure given in the Rectifier Test.

CONCLUSIONS FROM THESE TESTS

1. No voltage or low voltage in Test 1 indicates open circuit or high resistance connection in switch or wiring from switch to alternator.
2. No reading in "OFF" position indicates open circuit in resistance or switch which would give high charge in off position.
3. Faulty rectifier or rectifier cable connections would result in no charge.

TEST PROCEDURE

SERIES 'A'

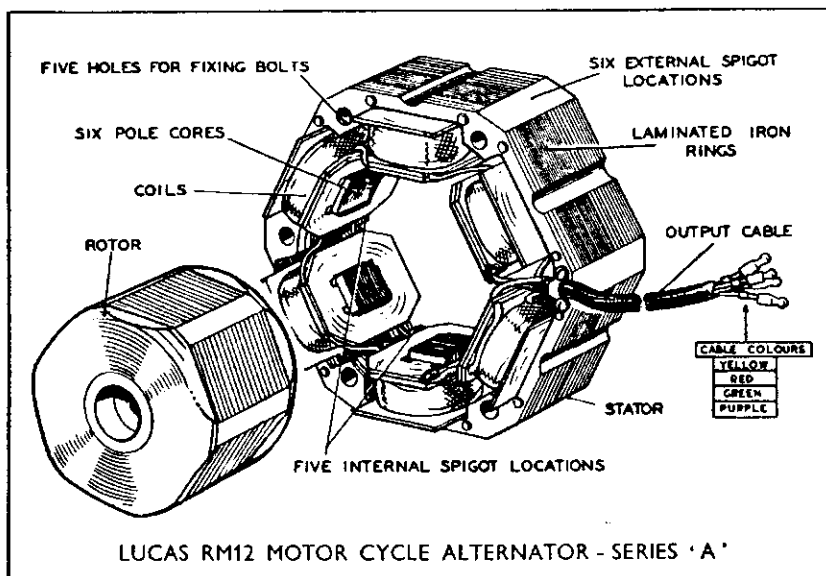

SERIES 'C'

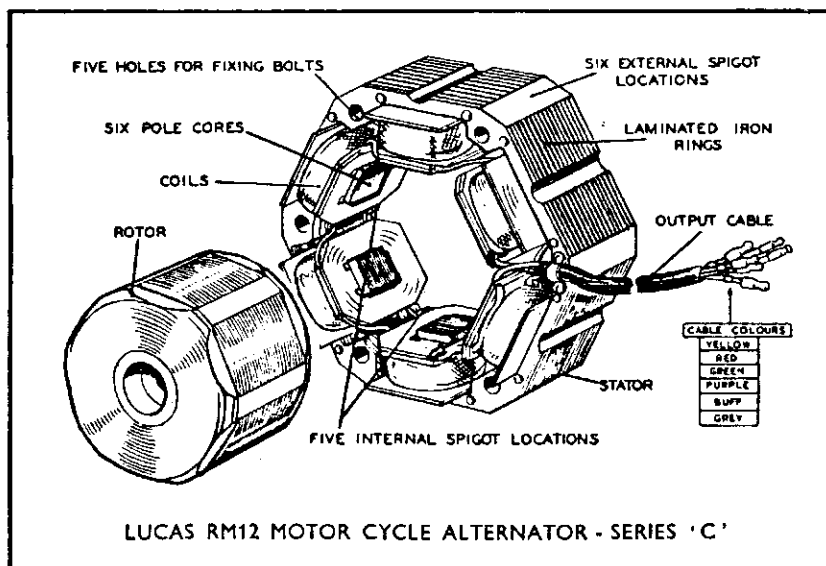

RM12 ALTERNATOR SET

Checking D.C. Input to Battery

TEST 1. Ammeter connected in series with main lead and battery.

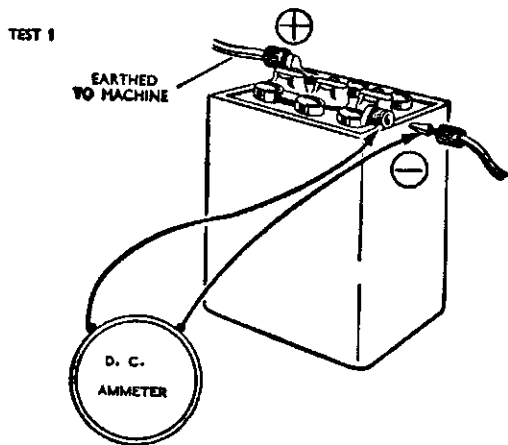

TEST 2. Disconnect main lead from battery. Connect 1 ohm resistor in place of battery. Feed ignition coil separately from battery. Turn ignition switch to IGN position.

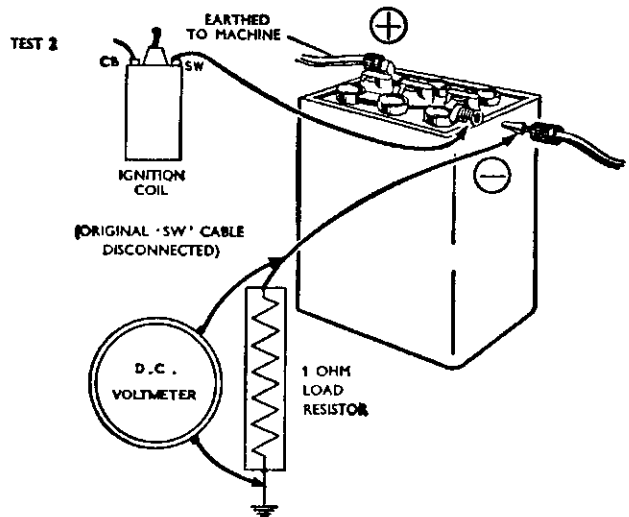

If battery is in poor condition or low state of charge use TEST 2.

Test	Switch Position	Reading Amps. at 3,000 r.p.m.
1	OFF	2.5 (min.)
	LOW	2.5 (min.)
	HIGH	3.5 (min.)

Test	Switch Position	Reading Volts at 3,000 r.p.m.
2	OFF	2.0 (min.)
	LOW	3.0 (min.)
	HIGH	4.0 (min.)

CONCLUSIONS FROM THESE TESTS

Test 1. If meter readings are as stated, the charging circuit and alternator are satisfactory.

No reading; check the alternator.
A high reading can be due to a short-circuited battery cell.

A low reading can be caused by a faulty battery. Proceed with Test 2. If readings still low check battery with hydrometer and discharge tester.

Test 2. If meter readings are lower or higher than values stated, check the alternator.
No reading on meter, check the rectifier.

IMPORTANT

Inaccurate readings can be due to faulty wiring, bad connections at the snap connectors. Make a quick visual check of all connections before proceeding with the tests.

Remember it is no use carrying out Test 1 if the battery is faulty or in a low state of charge, if in doubt proceed with Test 2.

Testing the RM12, Series "A" or Series "C" Alternator on the Machine, using an A.C. voltmeter and 1 Ohm Load Resistor

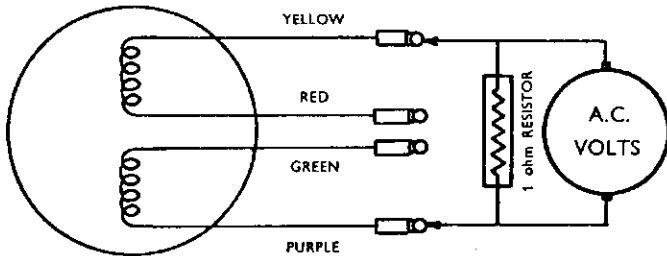

SERIES 'A' (Four Lead)

Test	Voltmeter and Resistor Connected Across	Reading Volts at 3,000 r.p.m.
1	YELLOW AND RED	8.0 (min.)
2	GREEN AND PURPLE	8.0 (min.)
3	YELLOW AND PURPLE WITH GREEN AND RED JOINED TOGETHER	6.0 (min.)
4	PURPLE AND GREEN WITH RED AND YELLOW JOINED TOGETHER	5.5 (min.)
5	ANY ONE LEAD AND GENERATOR STATOR (EARTH)	NO READING

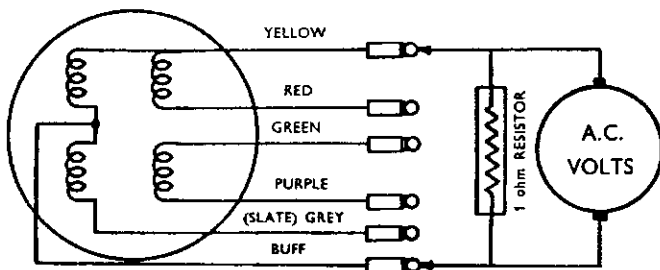

SERIES 'C' (Six Lead)

Test	Voltmeter and Resistor Connected Across	Reading Volts at 3,000 r.p.m.
1	YELLOW AND RED	7.25 (min.)
2	YELLOW AND BUFF	7.25 (min.)
3	GREY AND BUFF	7.25 (min.)
4	GREEN AND PURPLE	7.25 (min.)
5	ANY ONE LEAD AND GENERATOR STATOR (EARTH)	NO READING

CONCLUSIONS FROM THESE TESTS

Low reading on any coil indicates partially earthed or shorted turns. Zero reading will indicate open-circuit or earthed coil.

If all coils read low, partial de-magnetisation of rotor may have occurred as a result of faulty rectifier. Check rectifier, and battery earth polarity before replacing rotor.

A reading between any one lead and the generator stator indicates an earthed coil. Replace stator or locate the earth fault by isolating and testing the individual coils.

IMPORTANT

With the engine running at 3,000 rev./min. approx., the output voltages are steady, and even if the engine is running a few r.p.m. faster or slower the values stated in the tests will be obtained from a good alternator.

Rectifier—Bench Testing

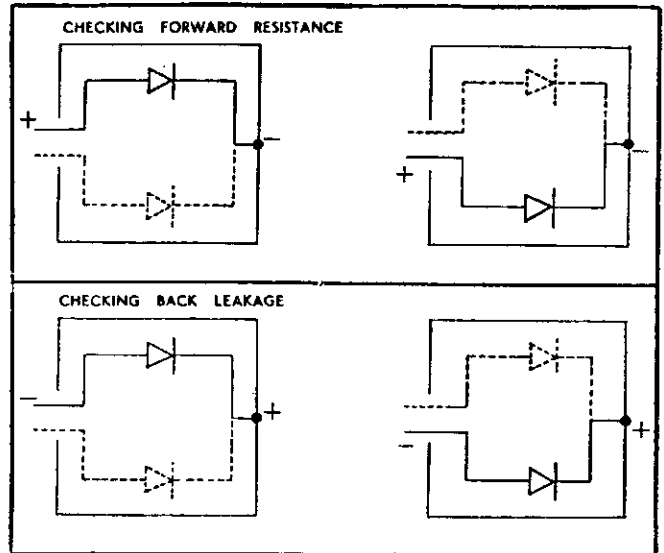
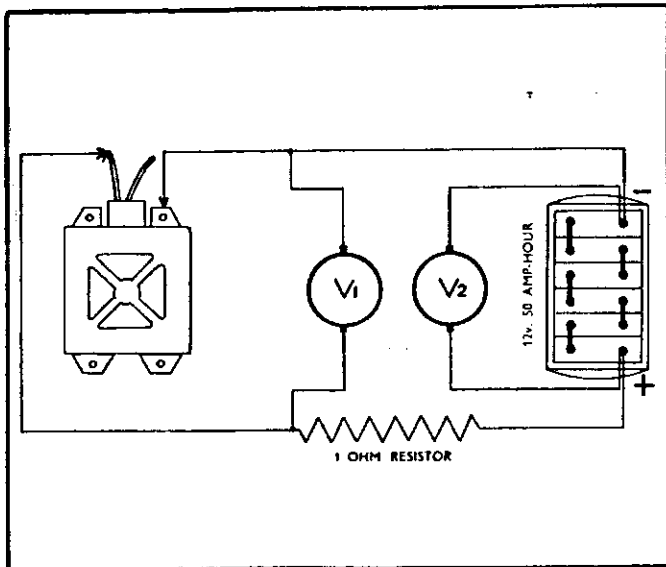

- V1 — will measure the volt drop across the rectifier cell, which should not be greater than 2.5 volts.
 V2 — must be checked when testing the rectifier cell, to make certain the supply voltage is 12 volts on load.

It is essential that the supply is kept at 12 volts for these tests.

FORWARD RESISTANCE TEST

Test 1. Connect negative lead to rectifier case. Connect positive lead to each cable connector in turn; reading on V1 should not be greater than 2.5 volts. Keep the testing time as short as possible to avoid overheating the rectifier cell.

BACK LEAKAGE TEST

Test 2. Connect positive test lead to case; negative test lead to each cable connector in turn. Reading on V1 should not be below 10 volts.

CONCLUSIONS FROM THESE TESTS

If the voltage reading, in Test 1, is exceeded on either rectifier cell, the unit is aged and should be replaced.

If the reading in Test 2 is well below 10 volts, on either or both cells, the rectifier is shorted internally and should be replaced.

DOUBLE BANK RECTIFIER (47094) USED WITH THE RM12 SERIES "A"

The test procedure and figures for this rectifier are as quoted in the above tests. But it will be necessary to disconnect the two leads which are connected to the rectifier fixing bolts, before testing the two units separately.

IMPORTANT

There are two types of Westinghouse rectifiers in service on LUCAS sets. The original having low voltage plates being identified by the figures 2L stamped on the case, the other which has high voltage plates being identified by the figures 12L.

The values quoted in the above tests are for the high voltage rectifiers 12L. When testing a low voltage rectifier 2L the Forward Resistance reading should be the same but the Back Leakage figure can be down to 9-volts.

Testing the External Wiring Circuit on RM12 Series 'C' Sets

USING D.C. VOLTMETER WITH 1 OHM LOAD IN PARALLEL

1. Connect red test lead to EARTH.
2. Disconnect six alternator cables from main harness (located under saddle).

Test Alternator Wiring through Ignition Switch

3. With ignition switch OFF connect black test lead to each of the six main harness cables. Voltmeter should read zero on all six cables.
4. With ignition switch ON, repeat operation as above. Voltmeter should read battery volts on GREEN cable. Remainder zero.

Test Alternator Wiring through Headlamp Switch

5. With ignition switch still ON, operate lighting switch to "Head" position. Battery volts should also register at BUFF cable.

Test Alternator Wiring through Switch in "Emergency Start" position

6. Turn ignition switch to emergency position when there should be no voltage reading at any of the six connections.

NOTE

These tests are to be carried out in the case of "No Charge" or "No Emergency Start" if previous tests have been carried out and all is in order.

Testing the 'High' and 'Low' Charge Switch Circuits

USING D.C. VOLTMETER WITH 1 OHM LOAD IN PARALLEL

1. With the alternator leads still disconnected, disconnect the battery.
2. Connect the red lead to positive terminal of battery.
3. Connect a wander lead to negative battery terminal.
4. Use the negative lead from voltmeter and wander lead to make the following continuity test.

TEST A

Continuity through light switch cables and light switch in the "OFF" and "LOW" positions, with the ignition switched on.

Connect test leads to yellow and grey cables which should be common and register approximately battery volts.

TEST B

Continuity through cables and light switch in the "HEAD" position, with the ignition switched on.

Connect test leads to grey and purple cables. If correct, meter should register battery volts.

TEST C

Continuity through cables and ignition switch in the "EMERGENCY START" position.

Connect test leads to purple and grey, purple and red, grey and red leads from resistance which should all be common and register approximately battery volts.

TEST D

Repeat the operation for red and blue leads from resistance which should read battery volts if correct.

NOTE

Incorrect switching of these cables will cause incorrect charging rates, i.e., failure of yellow and grey to link together will cause high charge rate with headlight switch off.

In the case of incorrect switch it is necessary to remove the switches from panel and check connections and if necessary the switch itself.

TEST PROCEDURE

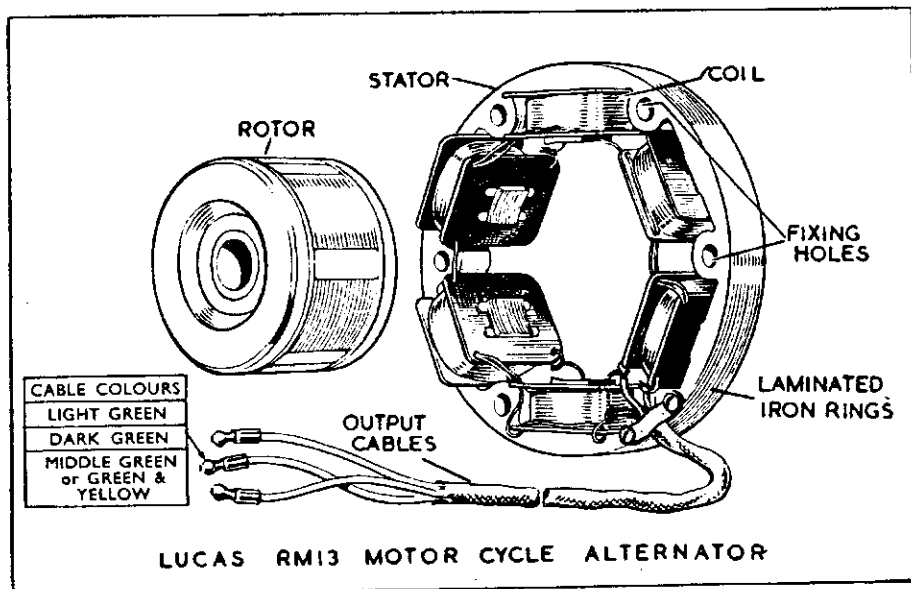

RM13 - RM13/15 - RM14 - RM15 - RM18 - RM19 - RM20/19 - 5AF - 9AF
ALTERNATOR SETS (6 and 12-volt)

Checking the Rectifier D.C. Current Output — on the Machine

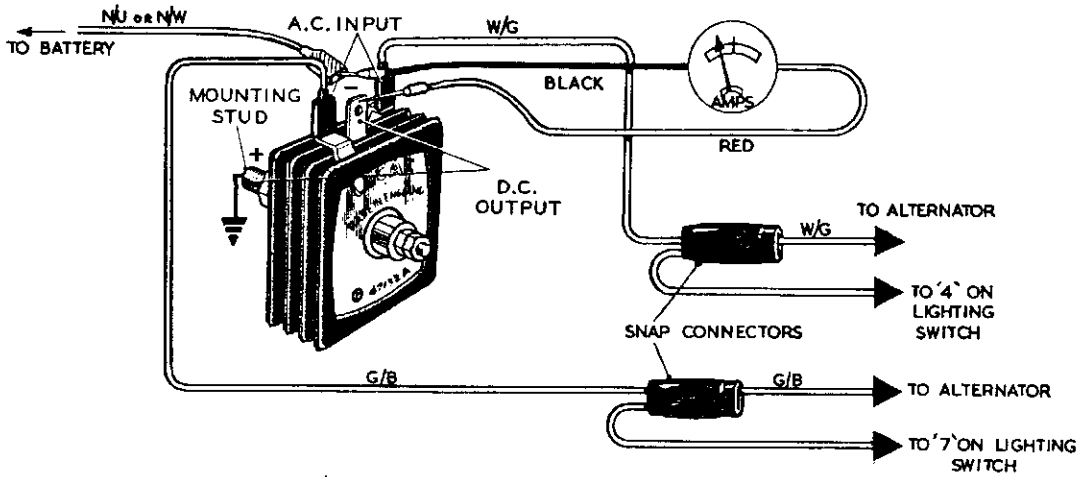

SILICON DIODE RECTIFIER

The latest type of rectifier, fitted on current machines is a Silicon Diode type. The terminal arrangement is the same as for the Selenium type

SELENIUM RECTIFIER

NOTE

SEE TEST DATA CARD IN REAR COVER POCKET FOR LIST OF APPROPRIATE TEST VALUES

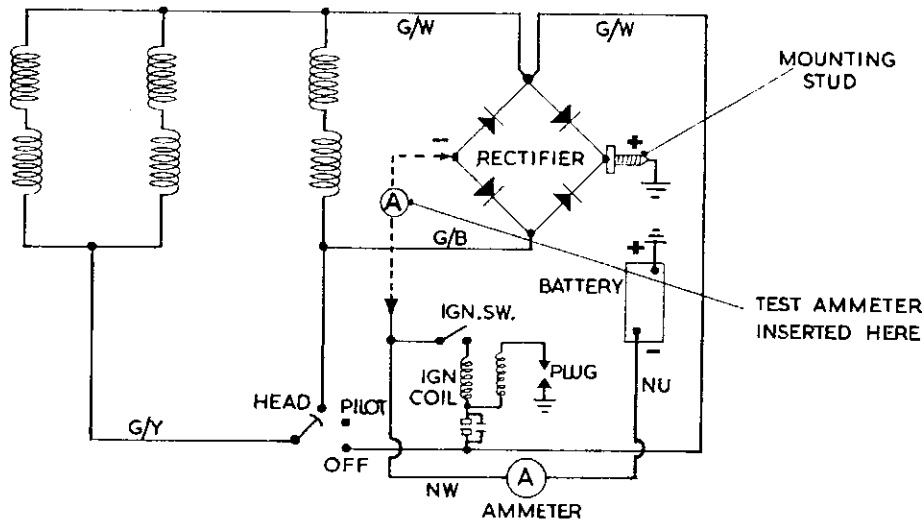

Checking the Rectifier D.C. Current Output — on the Machine

TEST PROCEDURE

- (a) First check state of charge of battery on machine. If it is not in a healthy, well-charged condition it must be temporarily replaced with a fully-charged one, *before* testing.
- (b) Remove cable(s) from the centre terminal of rectifier.
- (c) Disconnect Zener Diode, when fitted.
- (d) Connect ammeter Black lead to cable(s) removed, and ammeter Red lead to rectifier centre terminal.
- (e) Start engine and run at 3,000 rev/min.
- (f) Note reading on ammeter, with the lighting switch in the "Off", "Pilot", and "Head" positions. Readings should approximate the values given in the test data card for the appropriate alternator. (See inside rear cover for Test Data Card).

TEST CONCLUSIONS

If the ammeter registers the value stated for the equipment, the charging circuit and alternator are satisfactory.

No reading on the ammeter indicates either a faulty alternator or rectifier. To find out which is at fault apply the individual tests for the alternator and rectifier.

A faulty battery can cause "high" or "low" readings. If reading is "high" it can be due to a short-circuited battery cell, a "low" reading can be caused by a sulphated battery or faulty connections, or result from partial de-magnetisation of the alternator rotor.

IMPORTANT

No readings will be obtained if any wiring connections are open-circuited. Inaccurate readings can be due to faulty wiring such as poor earth connections, or "snap" connectors.

SERVICE NOTE

Remember that some alternator sets are connected to give a two-rate output while others are connected to give a three-rate output. In practice, this means that the actual values registered by the ammeter will differ slightly in the "off" and "pilot" positions, according to which wiring arrangement is used.

Alternators — Coil arrangements and connections

"Kill The CD Man" © 2003

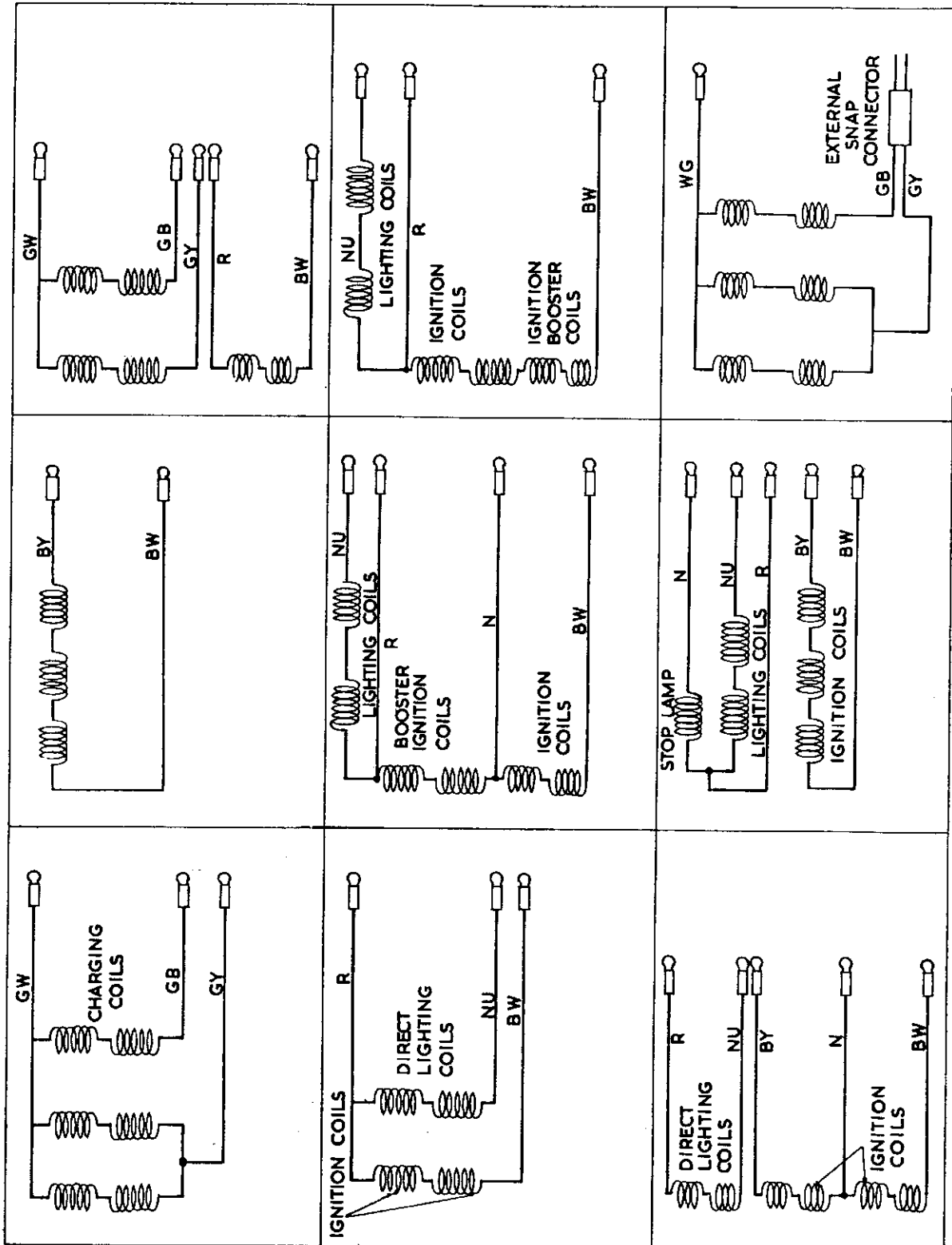

For checking with A.C. Voltmeter and 1 Ohm Load Resistor

TEST PROCEDURE

- (a) Disconnect the alternator cables, at the snap connectors where they are joined to the main harness.
- (b) Connect the A.C. voltmeter, with 1 ohm load resistor in parallel, across the alternator coils in the order detailed for the particular model under test. (See test data card in pocket of rear cover). The engine of the machine should be run at a constant speed, at approximately 3,000 rev/min, while making the test. The motor cycle should be on its rear stand, with Top Gear engaged. The speedometer can be used as a guide as to engine speed, a 45 mile/h reading approximately an engine speed of 3,000 rev/min. If a tachometer is fitted to the machine then an accurate assessment of engine speed is possible.

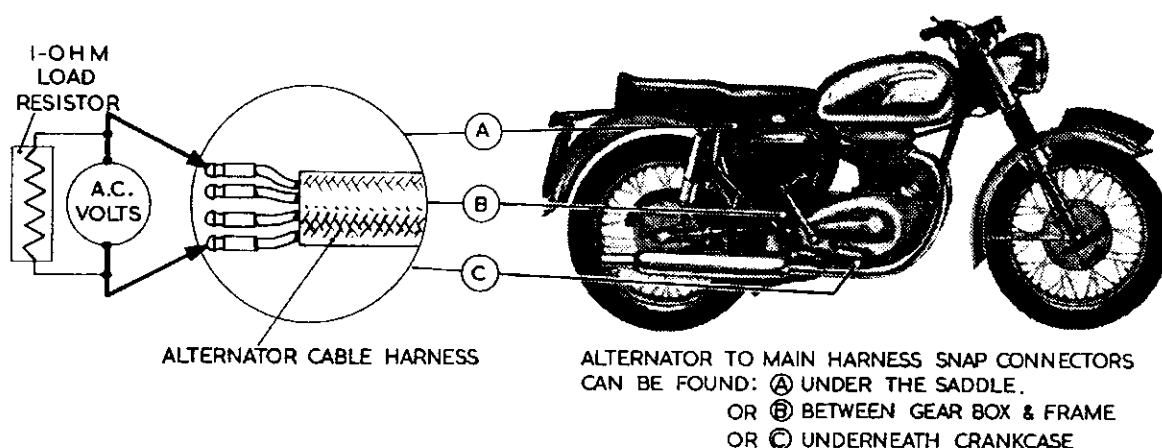

ALTERNATOR TO MAIN HARNESS SNAP CONNECTORS CAN BE FOUND: (A) UNDER THE SADDLE.
OR (B) BETWEEN GEAR BOX & FRAME
OR (C) UNDERNEATH CRANKCASE

TEST CONCLUSIONS

- A. A low reading on any group of coils indicates partially earthed or shorted turns.
- B. A zero reading on any group of coils will indicate an open-circuit coil.
- C. If all coils read low, partial de-magnetisation of rotor may have occurred as a result of faulty rectifier. Check rectifier, and battery earth polarity before replacing rotor.
- D. A reading between any one lead and the generator stator indicates an earthed coil. Replace stator or locate earth by isolating and testing individual coils.

NOTE

With the engine running at approximately 3,000 rev/min the output voltages are steady, and even if the engine is running a few rev./min. faster or slower the minimum values given in the Test Data Card will be obtained from a good alternator.

If the machine is not fitted with a rear wheel stand it will be necessary to find some other means of getting the rear wheels clear of the ground so that the engine can be run with top gear engaged.

Checking Rectifier in Position on Machine

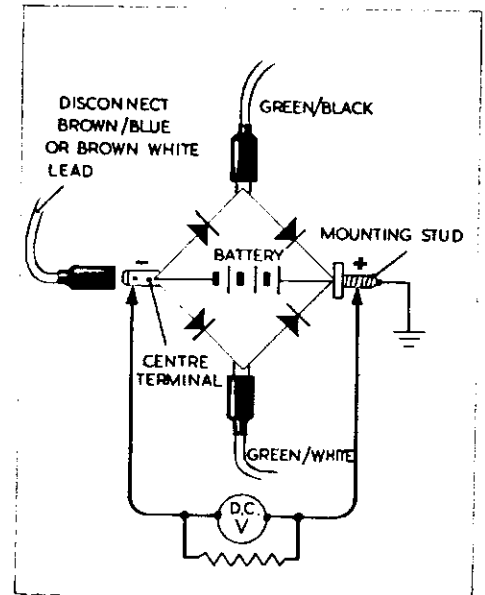
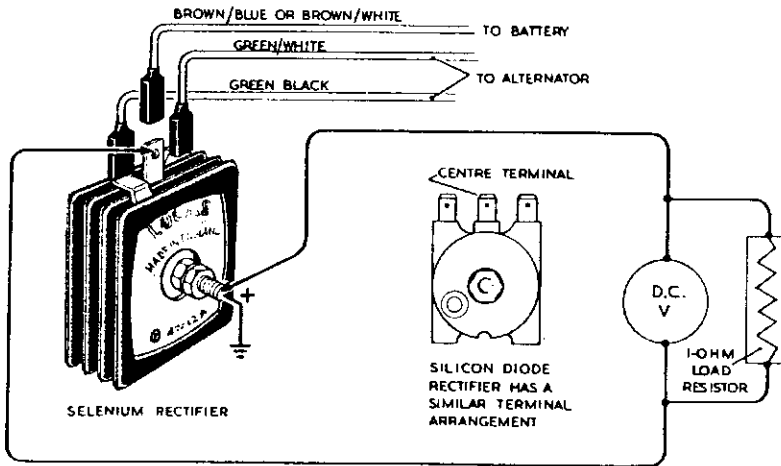

TEST PROCEDURE

- Check that alternator cables are correctly connected to main harness.
- Disconnect Zener Diode, if fitted.
- Disconnect cable(s) from rectifier centre terminal, and Green/Yellow cable at snap-connectors. With a "jumper" lead connect Green/Yellow to Green/Black at rectifier or snap-connector (this is done to ensure alternator will give its full output).
- Connect D.C. voltmeter and load resistor, Red lead to rectifier mounting bolt (Earth), Black lead to rectifier centre terminal.
- Run engine at 3,000 rev/min (approximately 45 mile/h in top gear). Meter reading should approximate the value given for each model Alternator in the A.C. meter test, in which the connected across all six coils i.e., White/Green with Green/Black to Green/Yellow.

CONCLUSIONS

- If reading approximates value stated, rectifier is satisfactory.
- A low reading can result from a bad earth connection between rectifier and frame of machine.
- A very low reading indicates a faulty rectifier, remove for bench testing.

Rectifier (Selenium or Silicon Diode Types) — Bench Testing

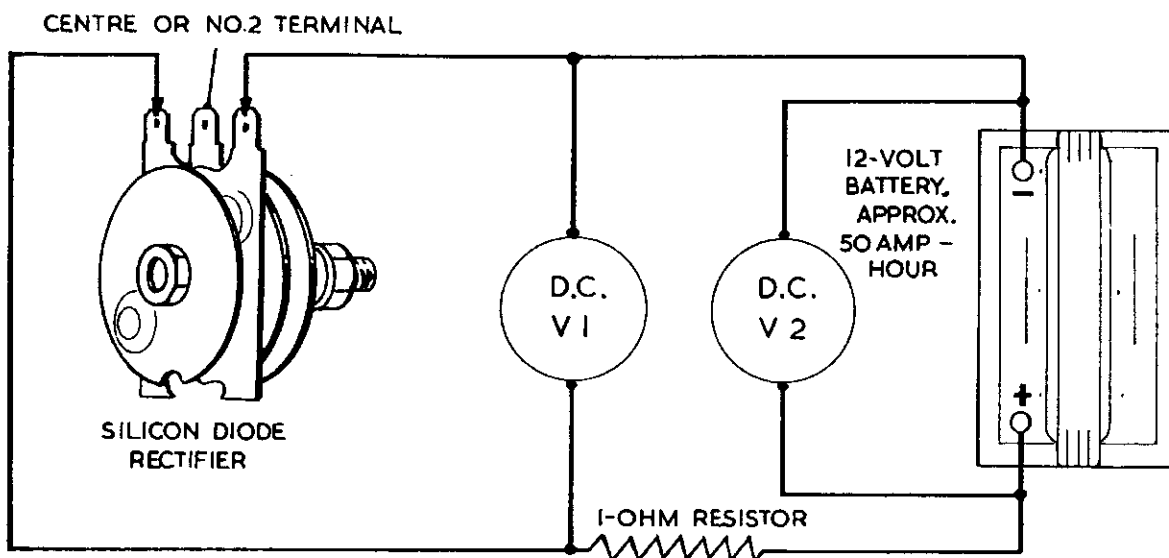

- V1 — will measure the volt drop across the rectifier cell, which should not be greater than 2.5 volts.
- V2 — must be checked when testing the rectifier cell, to make certain the supply voltage is 12 volts on load.

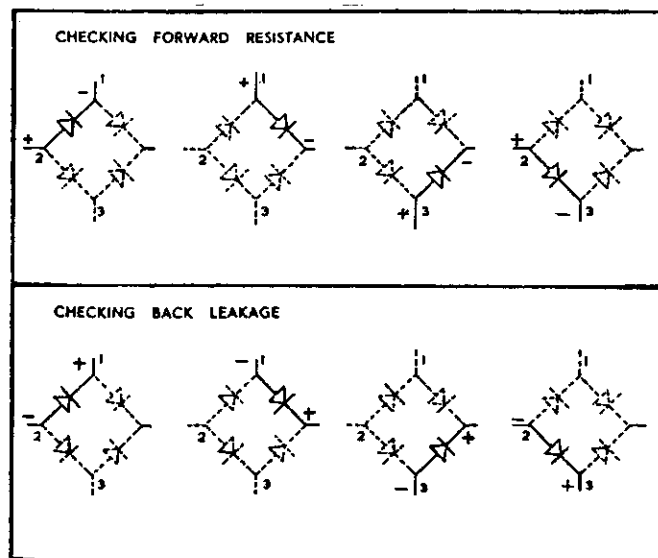

It is essential that the supply is kept at 12 volts for these tests.

FORWARD RESISTANCE TEST

Test 1. Connect test leads in turn across terminals 2 and 1 (Bolt and 1, Bolt and 3, 2 and 3. Reading in all positions should not be greater than 2.5 volts for Selenium types. For Silicon Diode types the reading should not be greater than 1.5 volts. Keep the testing time as short as possible to avoid overheating the rectifier cell.

BACK LEAKAGE TEST

Test 2. Proceed as for Test 1, and test each cell in turn, but reverse the test leads. Reading on V1 should not be less than 11 volts for Selenium types, and zero for Silicon Diode types.

CONCLUSIONS FROM THESE TESTS

Test 1. If the voltage reading on V1 is more than 2.5 volts for selenium rectifier, or more than 1.5 volts for silicon diode rectifier, on any cell, it is aged and the rectifier should be replaced.

Test 2. If the voltage reading on V2 is well below 11 volts for selenium rectifier, or not zero for silicon diode rectifier, on all cells, then the unit is faulty and should be replaced.

IMPORTANT

Before fitting a replacement rectifier check the following points:

1. Check that battery is correctly connected, POSITIVE to EARTH.
2. Check rectifier visually for signs of damage.

NEVER disturb the tension of the nut which holds the elements together on the through bolt of selenium plate rectifiers. The efficiency of the rectifier depends upon the correct tension of the plates. The tension of the nut is set before leaving the works, and cannot be adjusted correctly in service.

Checking the Zener Diode on the Machine (when fitted)

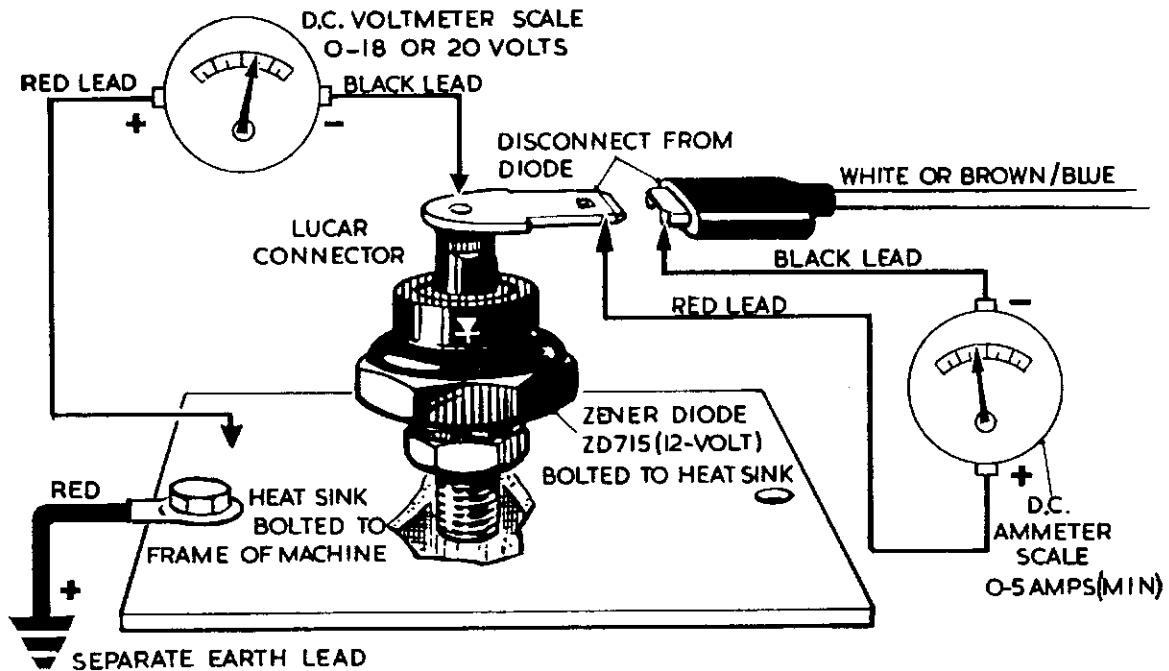

TEST PROCEDURE

Disconnect the lead from the Zener Diode and connect ammeter (in series) between the Diode Lucar terminal and lead previously disconnected. The ammeter red or positive lead must connect to the Diode terminal.

Connect D.C. voltmeter across Zener Diode and heat-sink. The red or positive lead must connect to the heat-sink which is earthed to the machine frame by its fixing bolts and a separate earth lead. The black lead connects to the Lucar terminal.

Ensure that all lights are "off", start the engine, and gradually increase engine speed, while at the same time observing both meters.

NOTE

It is essential that the batteries are in a good condition and in a reasonably good state of charge. If battery condition is uncertain, it should be temporarily replaced by a good battery for this test.

It may be necessary (particularly on magneto equipped machines which have only two coil charging) to reconnect the alternator for six coil charging or maximum output, i.e., join the alternator Green/Black and Green/Yellow leads together at the snap connectors.

- (i) When the voltage across the Zener Diode reaches 12.75 volts, the Zener current ammeter must indicate zero.
- (ii) Increase engine speed until a Zener current of 2 amperes is indicated on the ammeter. At this value a satisfactory Zener Diode should cause a reading on the voltmeter of between 13.5 and 15.5 volts.

TEST CONCLUSIONS

If the ammeter in test (i) registers any current at all before the voltmeter indicates that the voltage across the Zener is 12.75 volts, then a replacement Zener Diode must be fitted.

If test (i) proves satisfactory but in test (ii) a higher voltage than that stated is registered on the voltmeter, before the ammeter registers two amperes, then a replacement Zener Diode must be fitted.

2ET and 3ET Ignition Coils — Spark Performance Test Circuit

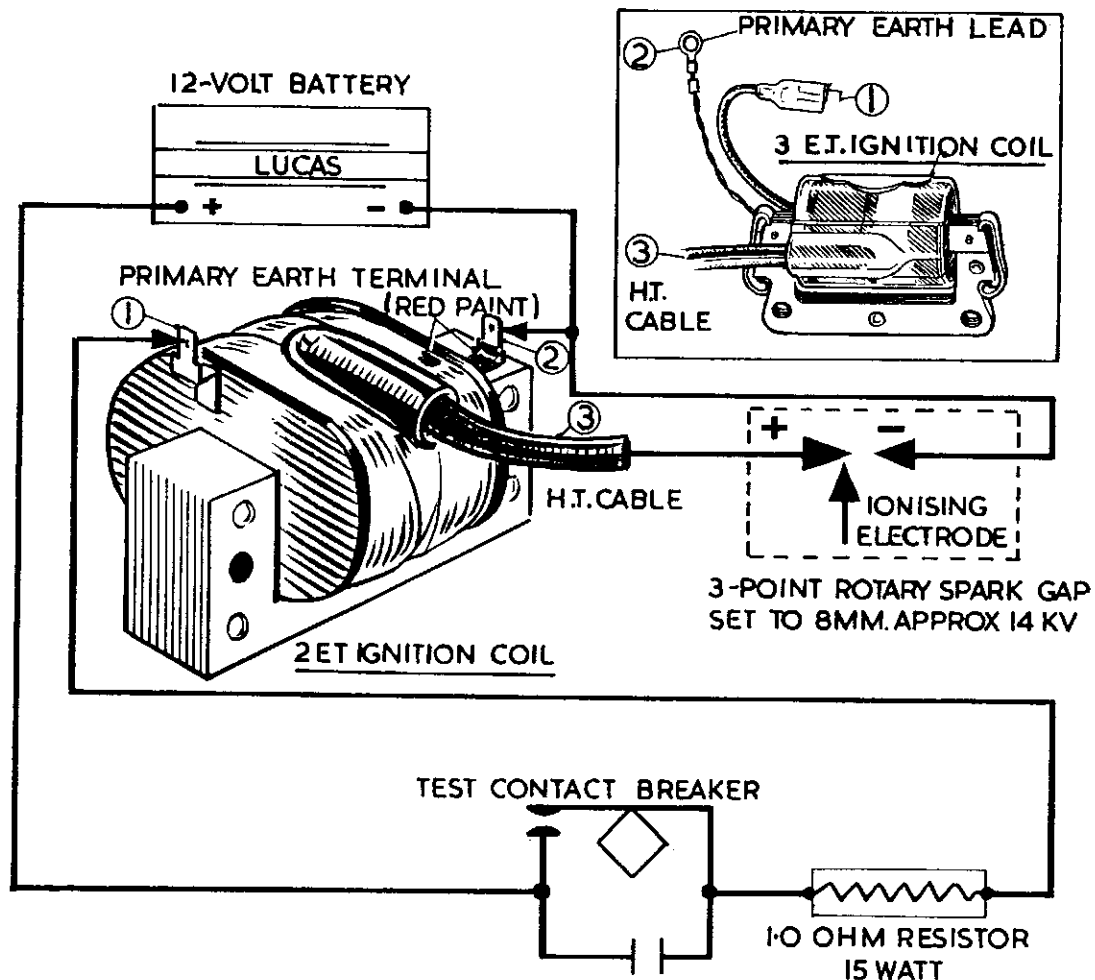
**TEST EQUIPMENT REQUIRED**

A four lobe D.M. type contact-breaker having closed periods of not less than 42° and having an operating range up to 750 rev/min. is required. Also, a 12-volt battery, a 3 point rotary spark gap and a 1 ohm resistor approximately 15 watt.

TEST PROCEDURE

- (a) Connect the 12 volt battery, contact-breaker, and 1.0 ohm resistor in series with the coil primary winding. Circuit polarity should be such that the negative side of the battery is connected to the earthed end of the primary winding.
- (b) Connect, with a "jumper" lead, the spark gap electrode that is farthest away from the ionising electrode, to the negative side of the circuit.
- (c) Connect the H.T. lead from the ignition coil to the 3 point spark gap, to the main electrode nearest to the ionising electrode.
- (d) Run the contact-breaker at 750 rev/min, when regular sparking should occur between the main electrodes when they are set to 8 mm. (approximately 14 kV.). Do not continue this test for longer than 30 seconds because arcing at the contact-breaker points will be fairly heavy, due to the slow running speed and low value primary resistance.

TEST CONCLUSIONS

Intermittent or no sparking, replace the coil.

Circuit Testing

USING D.C. VOLTMETER WITH 1 OHM LOAD IN PARALLEL

1. Disconnect alternator leads from main harness. All other cables, and battery, to be connected as normal. Connect voltmeter across battery (which should be in a well charged state) terminals, note the reading and proceed to 2.

Basic Charging Circuit

2. (a) Connect voltmeter red lead to earth.
- (b) Connect black lead to centre terminal on rectifier.
- (c) Turn ignition switch to "IGN" position; lighting switch to "off".
- (d) Reading on voltmeter should be not more than 1.0 volt below reading obtained in (1) above.

If a zero reading is obtained at rectifier centre terminal, check continuity of wiring circuit back through ignition switch to battery. A reading of more than 1.0 volt below the reading in (1) above, indicates high resistive or bad circuit connections.

Charging Control Circuit

TEST 1—Low Output Position

(Applicable to machines with Green/White lead at switch, and a link between switch terminals 5 and 6)

3. (a) Bridge together the centre and Green/White terminals of the rectifier.
- (b) Connect D.C. voltmeter (with 1 ohm resistor in parallel), black lead to Green/Yellow cable from ignition switch, red lead to earth.
- (c) Lighting switch in the "off" position.
- (d) Ignition switch in the "on" position.
- (e) Reading on meter should be not more than 1.0 volt below reading obtained in (1) above. See note 1.

TEST 2—High Output Position

(Applicable to all machines).

- (f) With voltmeter connected as in Test 1, bridge together the centre and Green/Black terminals of the rectifier.
- (g) Lighting switch in the "Head" position.
- (h) Ignition switch in the "On" position.
- (i) Reading on meter should be not more than 1.0 volt below reading obtained in (1) above. See Note 1.

A reading which is more than 1.0 volt below that obtained in (1) above, indicates high resistive or bad circuit connections.

NOTE 1

If Green/White lead is connected to terminal 4 on the PRS8, 63SA and 88SA switches, or terminal 7 on U39, 41SA. If no lead is fitted at 4 or 7 a zero reading will be obtained.

Emergency Start Circuit

(Twin cylinder machines with distributor)

4. (a) Disconnect alternator leads at the snap-connectors.
- (b) Connect Green/Yellow lead from switch to rectifier centre terminal, by means of a "jumper" lead.
- (c) Open distributor contacts.
- (d) Connect voltmeter with 1 ohm load, red lead to earth, black lead to "SW" (or "—") terminal of ignition coil.
- (e) Ignition switch in "EMG" position.
- (f) Reading on meter should be not more than 1.0 volt below reading obtained in (1) above.

(Single Cylinder Machines and Twin Cylinder Machines without Distributor, i.e., Twin Coil and Twin Contact-Breakers)

5. (a) Alternator leads still disconnected.
- (b) Distributor or contact-breaker contacts open.
- (c) Connect D.C. voltmeter with 1 ohm load, red lead to earth, black lead to "SW" (or "—") terminal of ignition coil.
- (d) Ignition switch in "EMG" position.
- (e) Reading on meter should be not more than 1.0 volt below reading obtained in (1) above.
- (f) Connect Green/Yellow lead from switch to rectifier centre terminal, by means of a jumper lead.
- (g) Move voltmeter black lead from "SW" (or "—") terminal to "CB" (or "+") terminal.
- (h) Ignition switch still in "EMG" position.
- (i) Reading on meter should be not more than 1.0 volt below reading obtained in (1) above.

If a zero reading is obtained check wiring and connections for continuity.

A reading which is more than 1.0 volt below that obtained in (1) above indicates high resistive or bad circuit connections.

NOTE 2

These tests are to be carried out in the case of "No Charge" or "No Emergency Start" if previous tests have been carried out and all is in order.

Remember, it is important that both ignition timing and rotor timing are correct for efficient operation of Emergency Start.

Location and Remedy of Faults

Although every precaution is taken to eliminate all possible causes of trouble, failure may occasionally develop through lack of attention to the equipment, or damage to the wiring. The following pages set out the recommended procedure for a systematic examination to locate and remedy the causes of some of the more probable faults. The sources of many troubles are by no means obvious, and in some cases a considerable amount of deduction from the symptoms is needed before the cause of the trouble is disclosed.

IGNITION CIRCUIT (see note, Substitute Ignition on page 58)

Engine will not start in IGN position

- Turn switch to EMG position. If the engine will now fire, the alternator and rectifier are operating correctly and the indication is a discharged battery; this can be confirmed by poor light from the lamps and hydrometer readings below 1.200. Recharge the battery if necessary.
- Remove the H.T. cable from the sparking plug terminal and hold it about $\frac{1}{8}$ -in. away from some metal part of the engine while the latter is slowly turned over. If sparks jump the gap regularly the ignition equipment is functioning correctly. Check for engine defects or examine sparking plug.
- If sparks do not occur in test (b), check for a fault in the low tension wiring, i.e., from battery to switch, coil and contact breaker. If the wiring proves to be in order, examine the contact breaker; if necessary clean the contacts and adjust the gap setting.

Engine will not start in EMG position (if provided)

- Remove the H.T. cable and test as described under (b) above; if sparks appear, then the trouble is due to engine defects, etc.
- If the ignition equipment is not operative in the above test, check the snap connectors, rectifier connections and other wiring. All connections must be clean and tight.
- Examine the contact breaker; if necessary clean the contacts and adjust the gap setting.
- Make sure ignition timing is correct to engine maker's specification.
- See that the alternator stator is fitted the correct way round on the engine shaft.

Engine misfires

- Examine the contact breaker; if necessary, clean the contacts and adjust the gap.
- Remove the sparking plug (or each plug in turn), rest it on the cylinder head and observe if a spark occurs at the plug points when the engine is turned. Irregular sparking may be due to dirty plugs, which may be cleaned and adjusted, or to defective high tension cables. Any cable on which the insulation shows signs of deterioration or cracking should be renewed.
- If sparking is regular at each plug when tested as described in (b), the trouble is probably due to engine defects, and the carburetter, petrol supply, etc., must be examined.

- If misfiring occurs after the engine has been running for some time, check that the ignition switch is in the normal IGN position. If run continuously in the EMG position, the rising voltage of the battery may eventually cause misfiring to occur.

A.C. IGNITION

Important

- Keep the contact breaker clean and its maximum opening correctly set to 0.014" — 0.016".
- Keep the sparking plug electrodes clean and correctly set.
- Keep to the manufacturer's timing instructions.

Regarding notes 1 and 3 above, it is the magneto performance or spark energy developed by the alternator (in addition to the piston-to-spark relationship) that is involved. Since the rotor is keyed to the engine crankshaft, which, in turn, is coupled through the connecting rod to the piston, any movement of the piston whilst timing will affect the position of the crankshaft, and hence the magnetic timing position of the rotor. Thus the maximum magneto performance of the alternator can only be obtained with accurately set contact breaker and timing.

Engine will not start, difficult to start or misfires

- Remove the H.T. cable from the sparking plug and hold the cable end about $\frac{1}{8}$ " from the cylinder block. Sparks should jump this gap regularly when the engine is turned at kick-start speed.
- If sparks are obtained, check the sparking plug, reset and clean, or renew as necessary.
- If no sparks are obtained, inspect the H.T. cable and renew, as necessary. Check contact breaker gap setting.
- If the sparking plug, H.T. cable and contact breaker gap setting are satisfactory, check for engine defects, faulty fuel supply, etc.

MAGNETO IGNITION

Engine will not start or difficult to start

- See that the controls are correctly set for starting, petrol turned on, etc.
- Turn off the petrol tap. Remove the sparking plug (or plugs), and place on the cylinder head. If a spark occurs regularly at the plug points when the engine is slowly hand-cranked, the magneto is in order. Look for engine defects and check ignition timing.
- If a spark does occur in (b), disconnect the high tension cable from the plug and hold the cable end about $\frac{1}{8}$ " from a metal part of the engine. If a spark occurs regularly when the engine is cranked, the plug is faulty. If there is no spark, disconnect the high tension cable at the magneto, replace with a new length of cable and test again as before.
- Should there still be no spark, possible causes of trouble are: contact breaker gap out of adjustment or contacts dirty; contact breaker rocker arm sticking; or, with rotary armature magnetos, pick-up brush worn or broken, or slip ring track dirty. Remedy as described.

Engine misfires

- Check as in para. (b) and (c) above to eliminate engine defects, faulty high tension cable and sparking plug.
- Check magneto as in para. (d) above.

Location and Remedy of Faults

CHARGING CIRCUIT

Battery in low state of charge

- (a) This state will be shown by poor or no light from the lamps when the engine is stationary, with a varying light intensity when the motor cycle is running.
- (b) If the engine starts and runs in the EMG position, this indicates that at least one plate of the rectifier is functioning correctly. But it should be checked.
- (c) Check the condition of the battery with a hydrometer. Top up, if necessary, and have battery recharged.
- (d) Check wiring from battery to switch, rectifier and alternator, tightening any loose connections or replacing broken cables.

Excess Circuit Voltage

- (a) This will be indicated by burnt-out or blackened bulbs, and possibly poor engine performance due to burned ignition contacts.
- (b) Examine all wiring for loose or broken connections.
- (c) Check the earthing of battery and rectifier.
- (d) Examine the battery for broken internal connections.
- (e) If the ignition is affected, clean the contact breaker contacts or if necessary renew them.

THE BATTERY POSITIVE (+ve) TERMINAL IS EARTHED TO THE MACHINE. UNDER NO CIRCUMSTANCES MUST THE NEGATIVE (-ve) TERMINAL BE EARTHED.

LIGHTING CIRCUITS

Failure of lights (machinery stationary)

- (a) If only one bulb fails to light, replace with new bulb.
- (b) If all lamps fail to light, test the state of charge of battery, recharging it if necessary either by a long period of daytime running or from an independent electrical supply.
- (c) Examine the wiring for a broken or loose connection, and remedy.

Lamps light when switch on, but gradually fade

Test the state of charge of the battery, recharging if necessary.

Brilliance varies with speed of motor cycle

Test the state of charge of the battery, recharging if necessary.

Lights flicker

Examine the wiring for loose connections, or short circuits caused by faulty cable insulation.

Headlamps illumination insufficient

- (a) If the bulb is discoloured or filaments have sagged as a result of long service, a new bulb of the same type should be fitted.
- (b) Check the setting of the lamp.

NOTE: MACHINES WITH A.C. IGNITION

SUBSTITUTE IGNITION EQUIPMENT

If an A.C. ignition machine cannot be started in order to carry out the test procedure, first check that the ignition timing and contact-breaker setting are in accordance with Manufacturer's recommendations. If they are satisfactory, and the ignition coil is suspect, a substitute ignition system can be connected to enable further tests to be carried out.

The procedure is as follows:—

Obtain a 6 or 12-volt battery and a standard type motor cycle ignition coil.

Connect battery Positive to frame of machine (Earth).

Negative to substitute ignition coil ("SW" or "-ve").

Connect coil ("CB" or "+ve") to motor cycle contact-breaker.

Remove existing cable from contact-breaker.

Start engine and proceed with tests.

LUCAS

**SELECTION OF CIRCUIT
AND
WIRING DIAGRAMS
FOR
MOTOR-CYCLES
fitted with
A.C. EQUIPMENT**

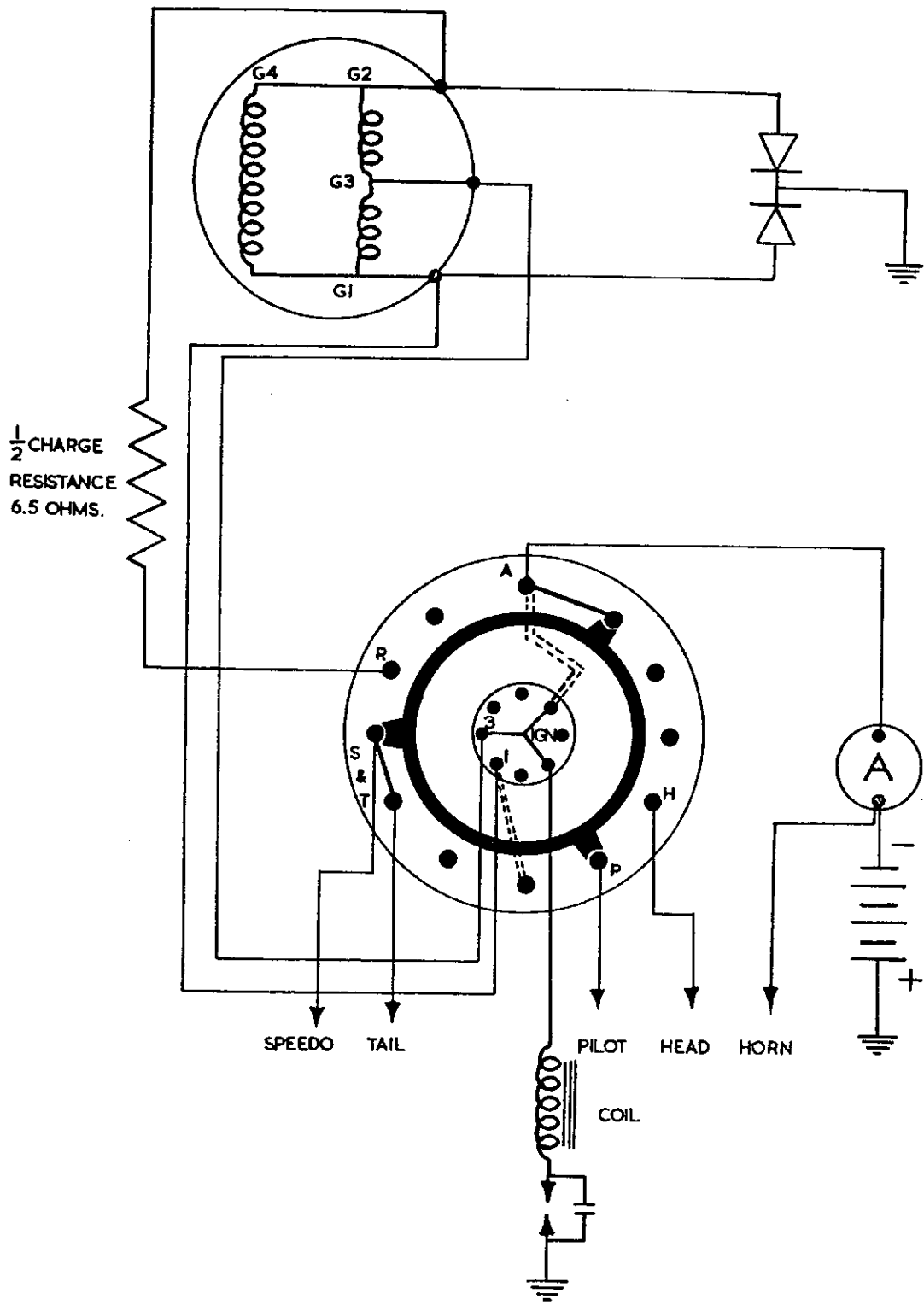

THEORETICAL DIAGRAM

IA45 — B.S.A. Bantam, Brockhouse Indian Brave, Dot and O.E.C. Machines

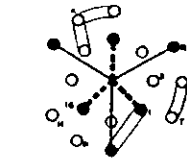

LIGHTING OFF
(TURN LT. SW TO 'D')
EMERGENCY IGNITION ON
(TURN IGNITION KEY LEFT)

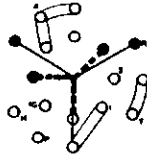

LIGHTING OFF
(TURN LT. SW LEFT TO 'O')
IGNITION OFF
(TURN IGNITION KEY CENTRAL)

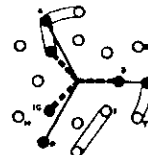

TAIL & PILOT LT'S ON
(TURN LT. SW RIGHT TO 'P')
IGNITION ON
(TURN IGNITION KEY RIGHT)



TAIL & HEAD LT'S ON
(TURN LT. SW. RIGHT TO 'H')

DIAGRAMS SHOWING SWITCH POSITIONS LOOKING ON TOP OF SWITCH

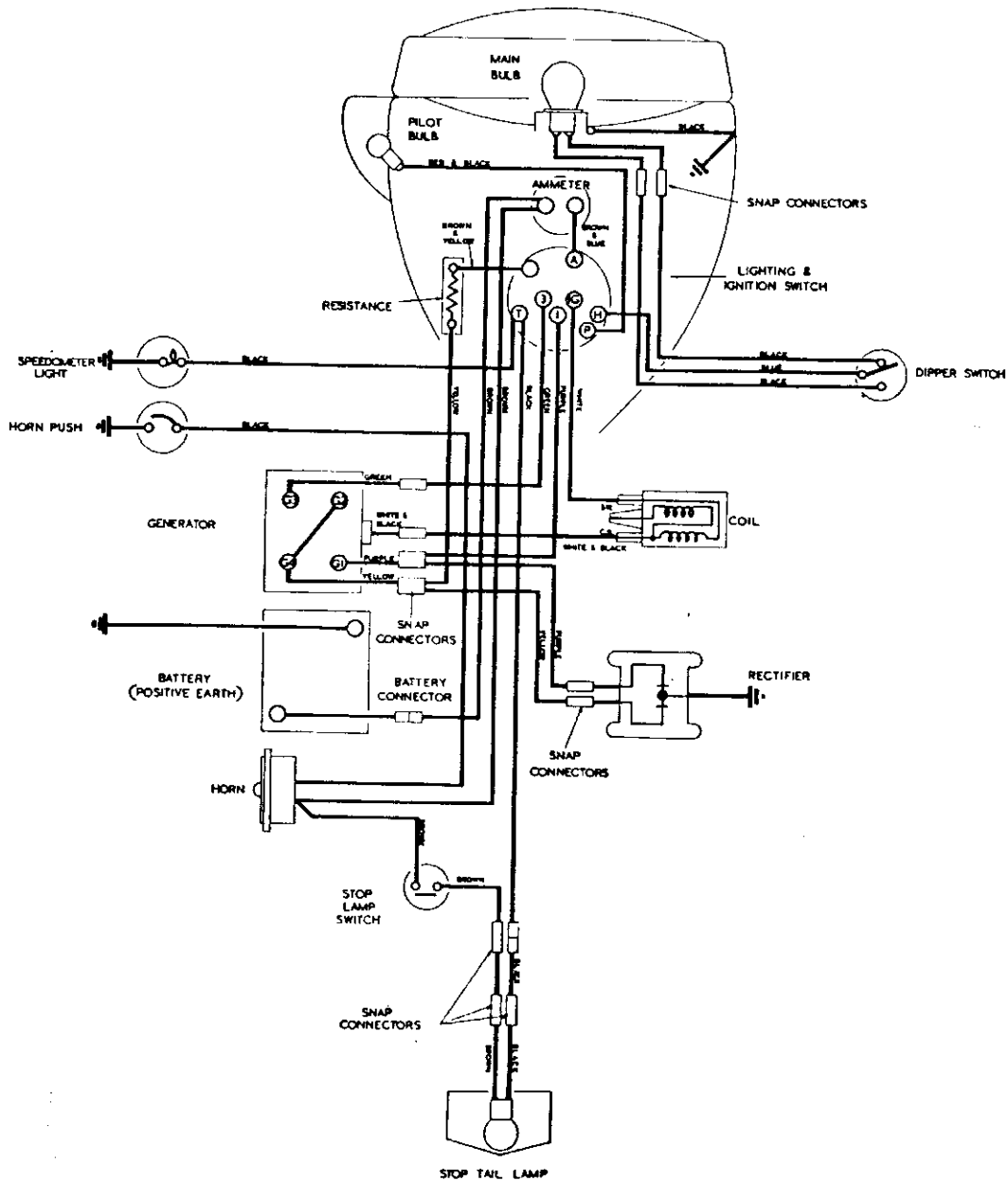

WIRING LAYOUT DIAGRAM

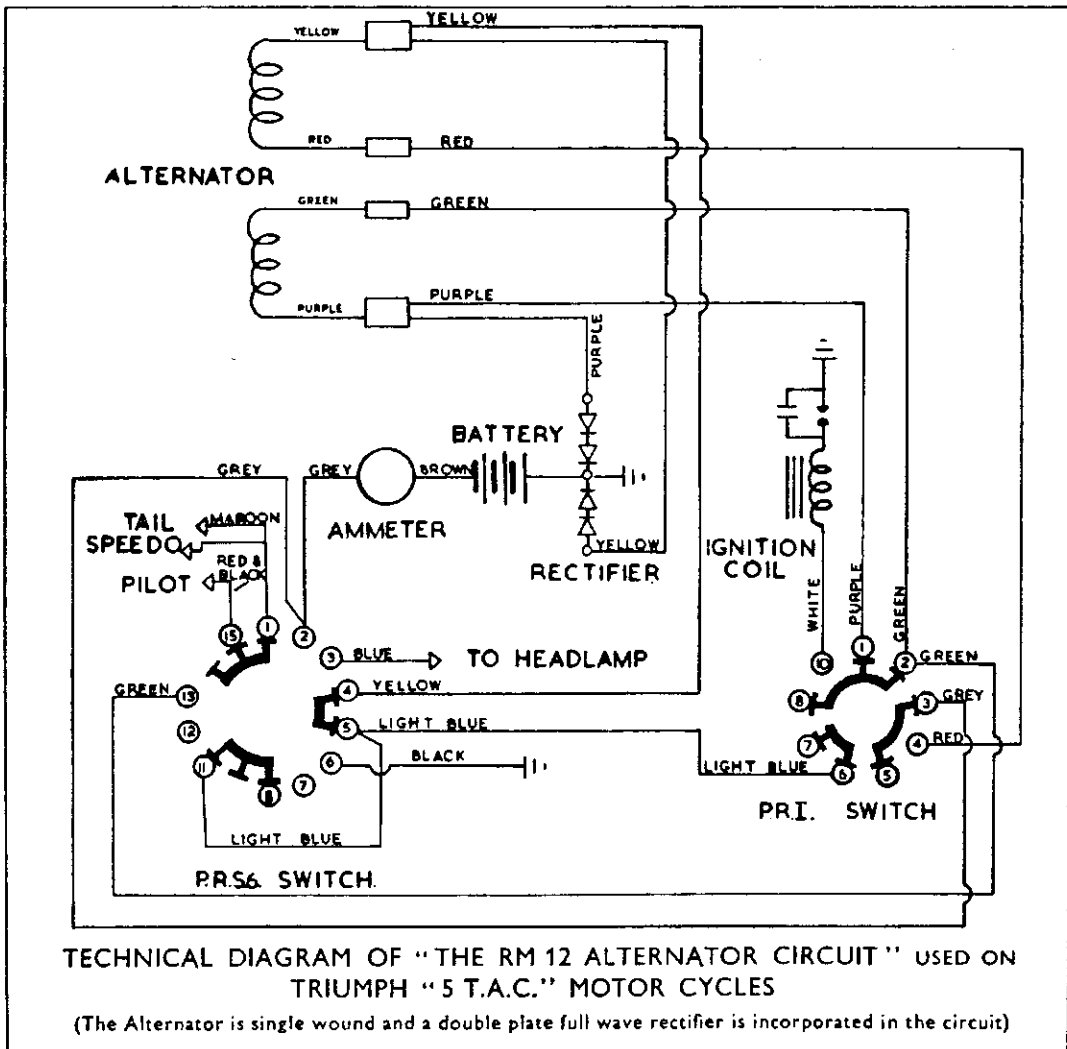

THEORETICAL DIAGRAM

RM12 Series "A" — Triumph 5 T.A.C. Engine and Frame Nos. 33868 — 35334 (inc.)

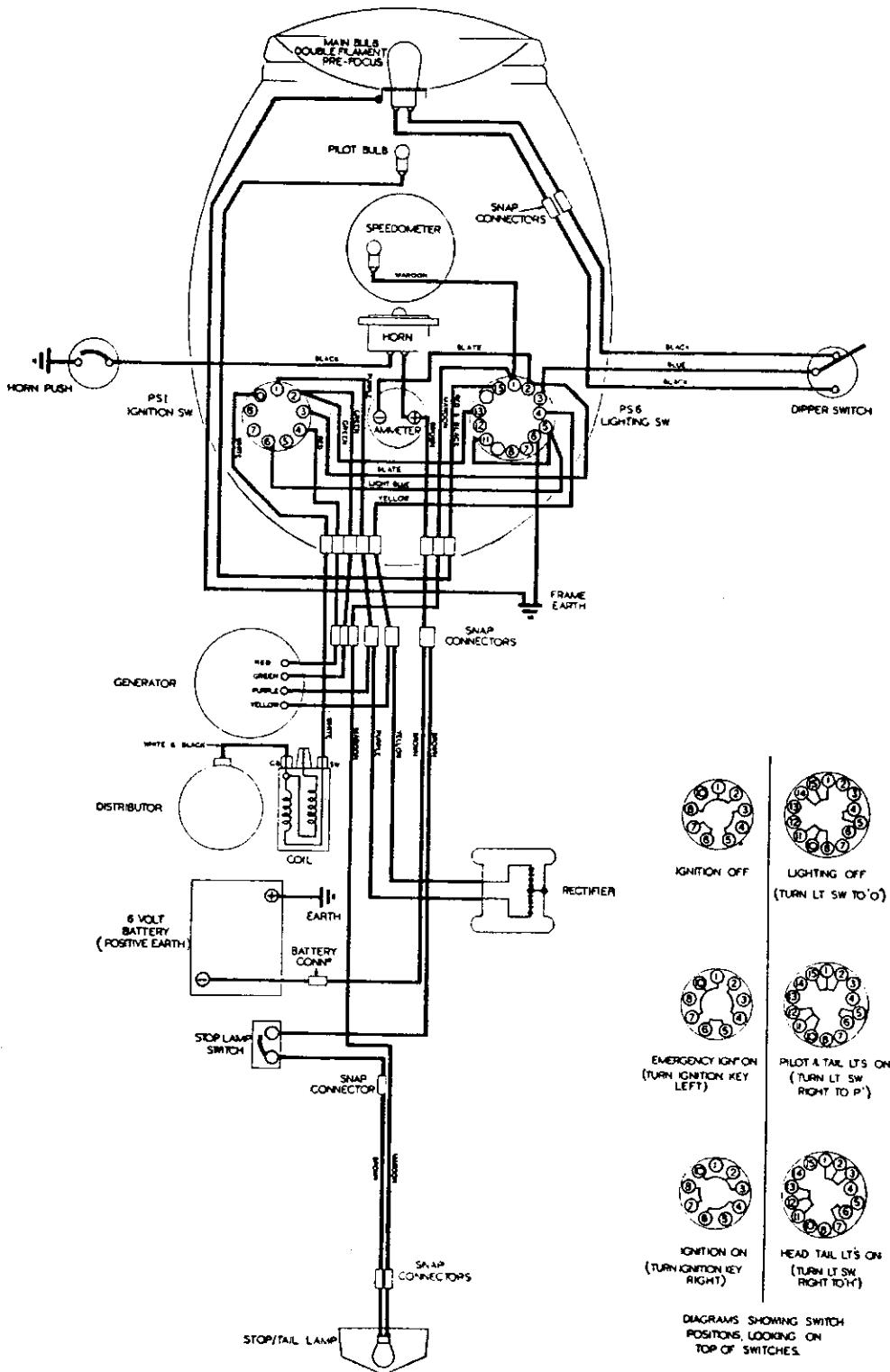

WIRING LAYOUT DIAGRAM

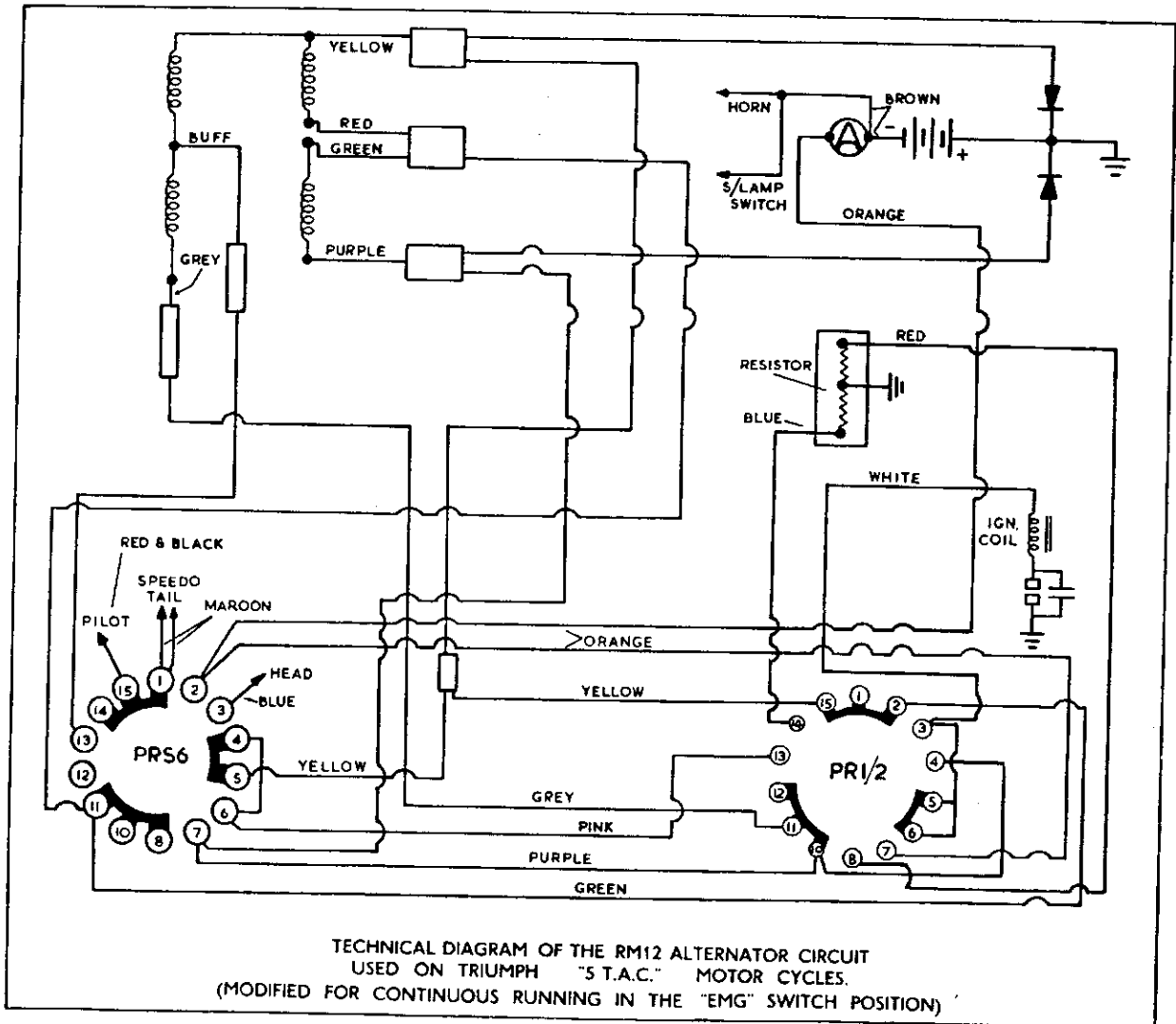

THEORETICAL DIAGRAM

RM12 Series "C" — Triumph 5 T.A.C. Engine and Frame Nos. 35335 — 44821 (inc.)

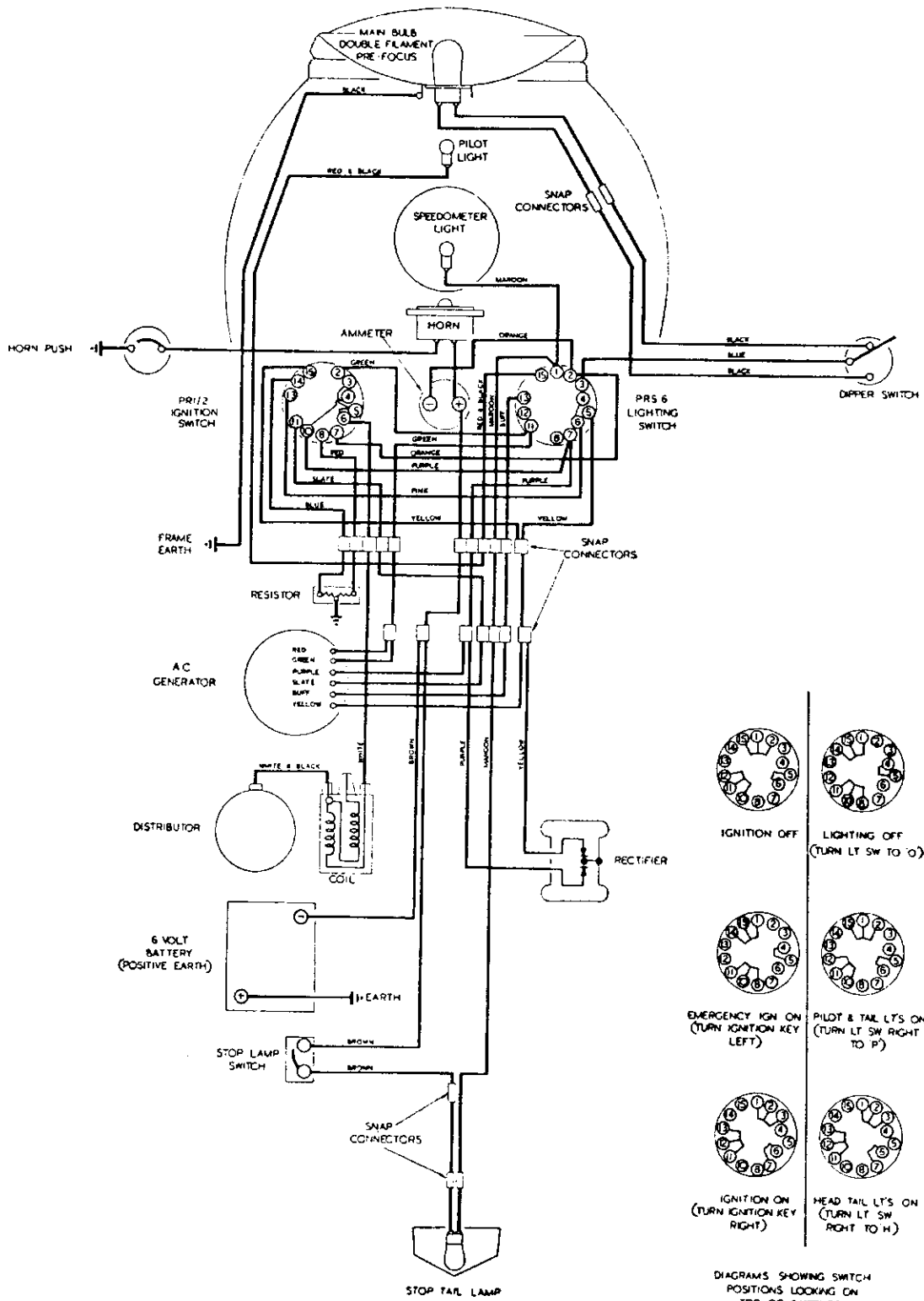

WIRING LAYOUT DIAGRAM

RM13 — Triumph "Terrier", "Tiger Cub" and B.S.A. CIIG Machines

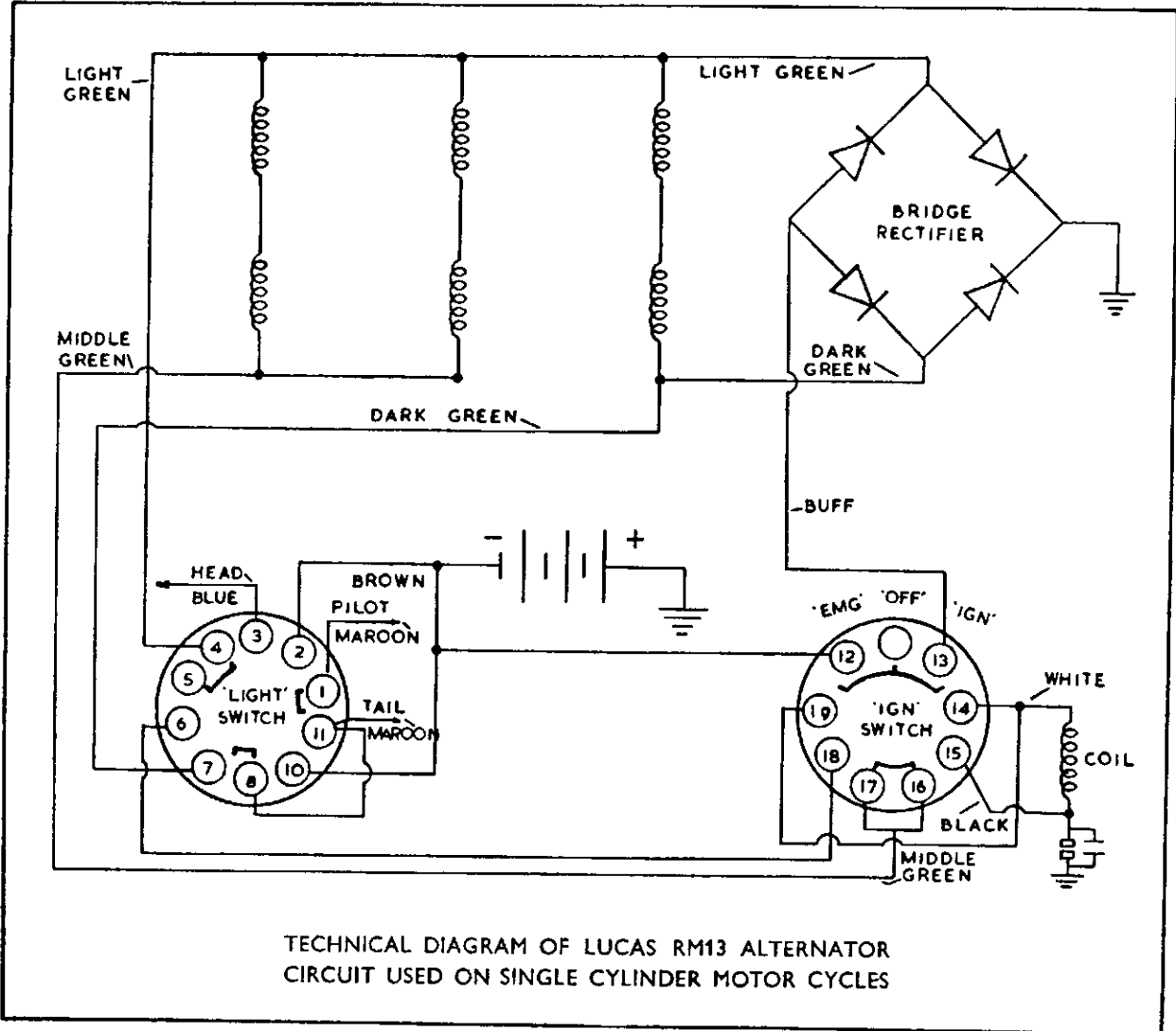

TECHNICAL DIAGRAM OF LUCAS RM13 ALTERNATOR
CIRCUIT USED ON SINGLE CYLINDER MOTOR CYCLES

THEORETICAL DIAGRAM

RM13 — B.S.A. CHG, Triumph "Terrier" and "Tiger Cub"

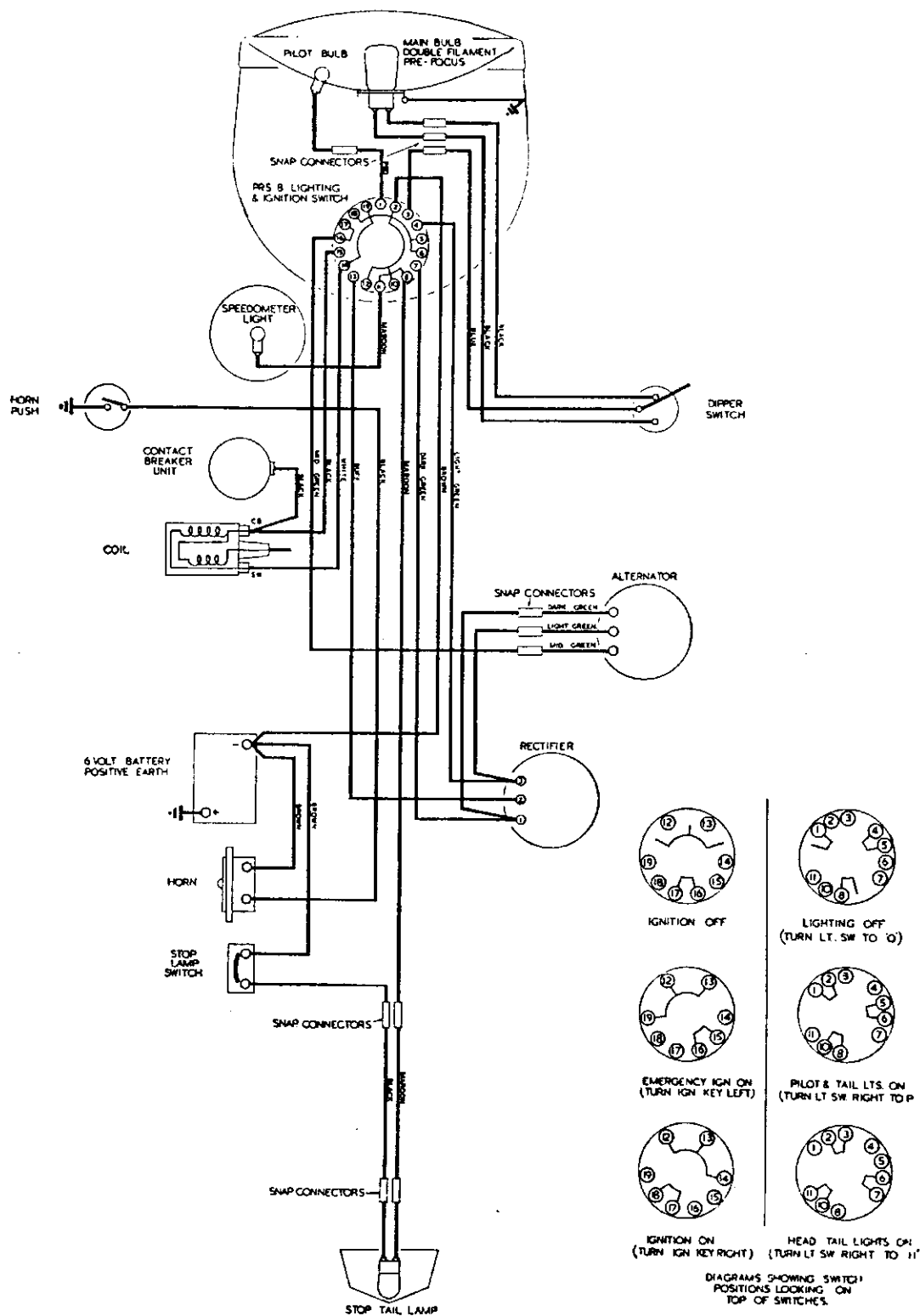

WIRING LAYOUT DIAGRAM

RM14 — Triumph 5 T.A.C. and 6 T.A.C. Engine Nos. 44822 (onwards)

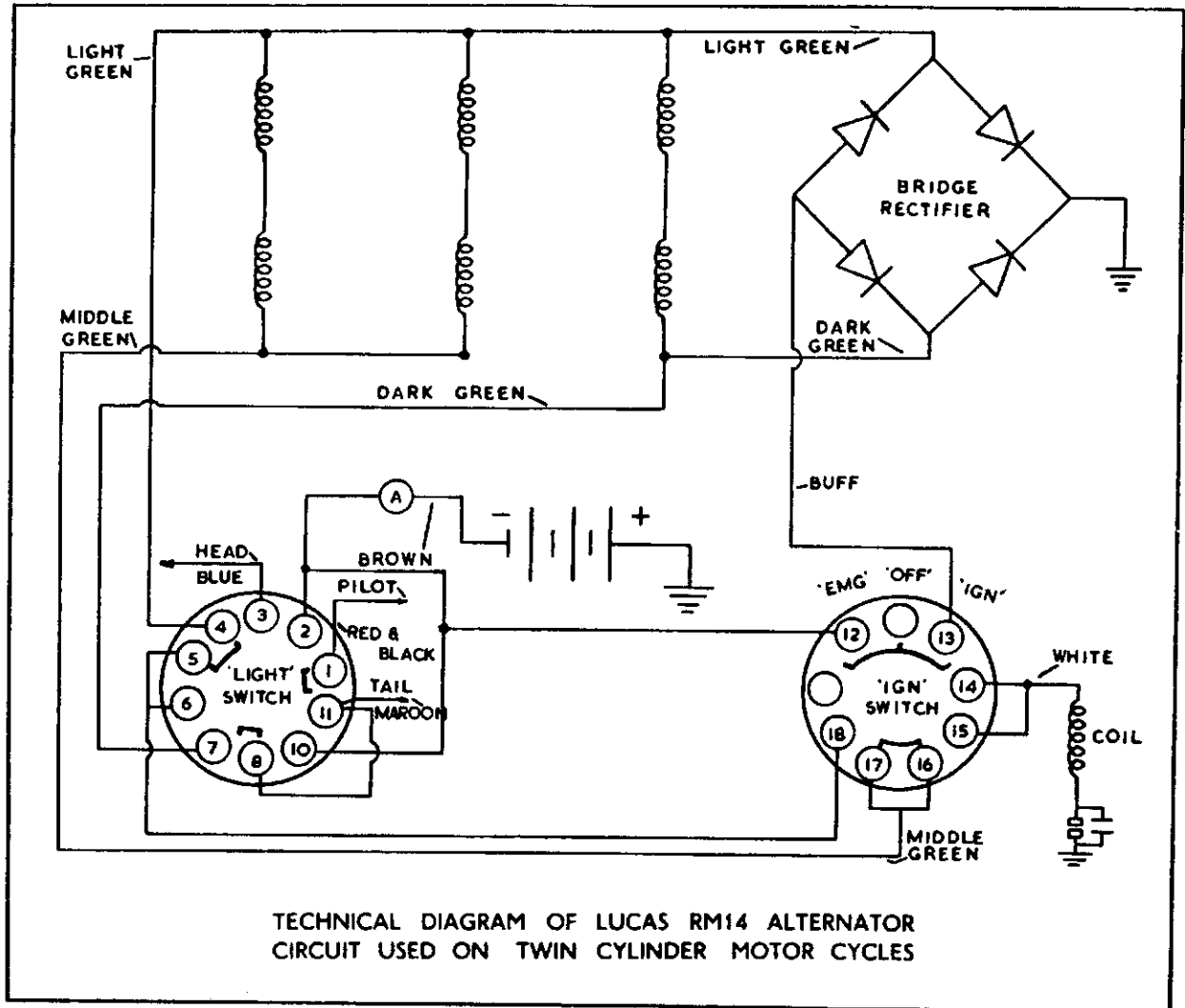

THEORETICAL DIAGRAM

RM14 — Triumph 5 T.A.C. and 6 T.A.C. Engine Nos. 44822 (onwards)

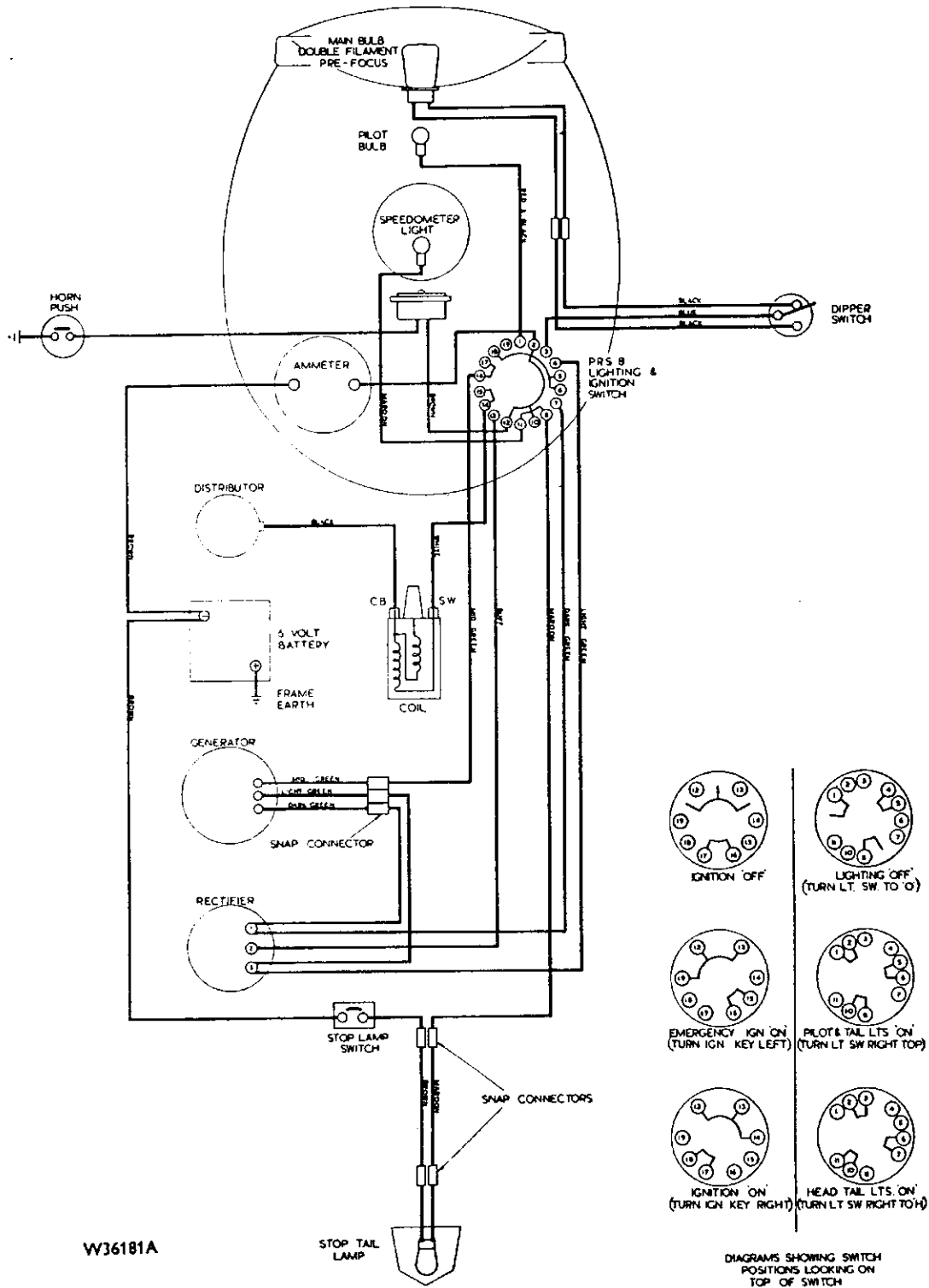

WIRING LAYOUT DIAGRAM

Rise The CD Man © 2008

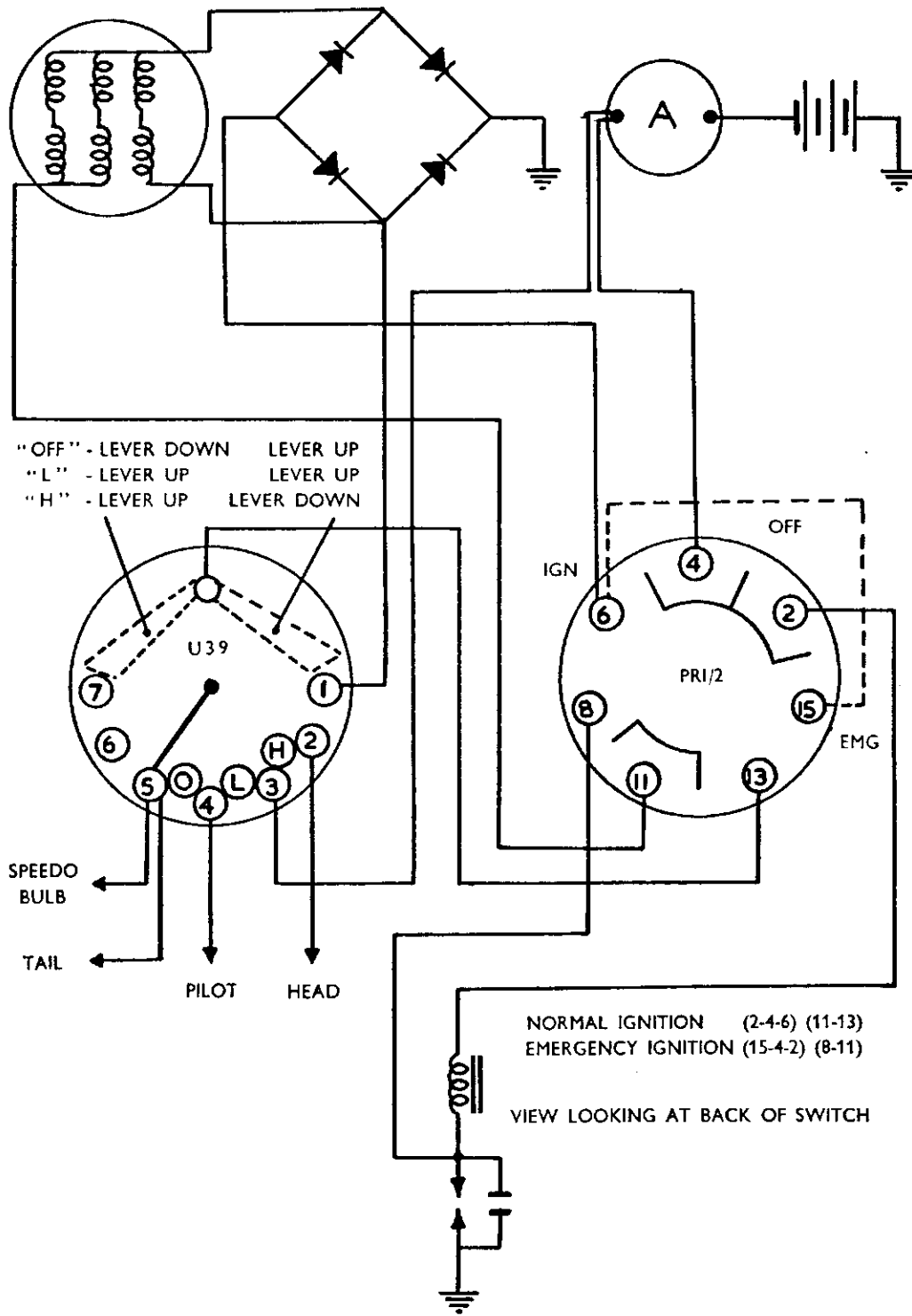

THEORETICAL DIAGRAM

RM13 — Brockhouse Indian Brave, Enfield Clipper or any Single Cylinder Machine

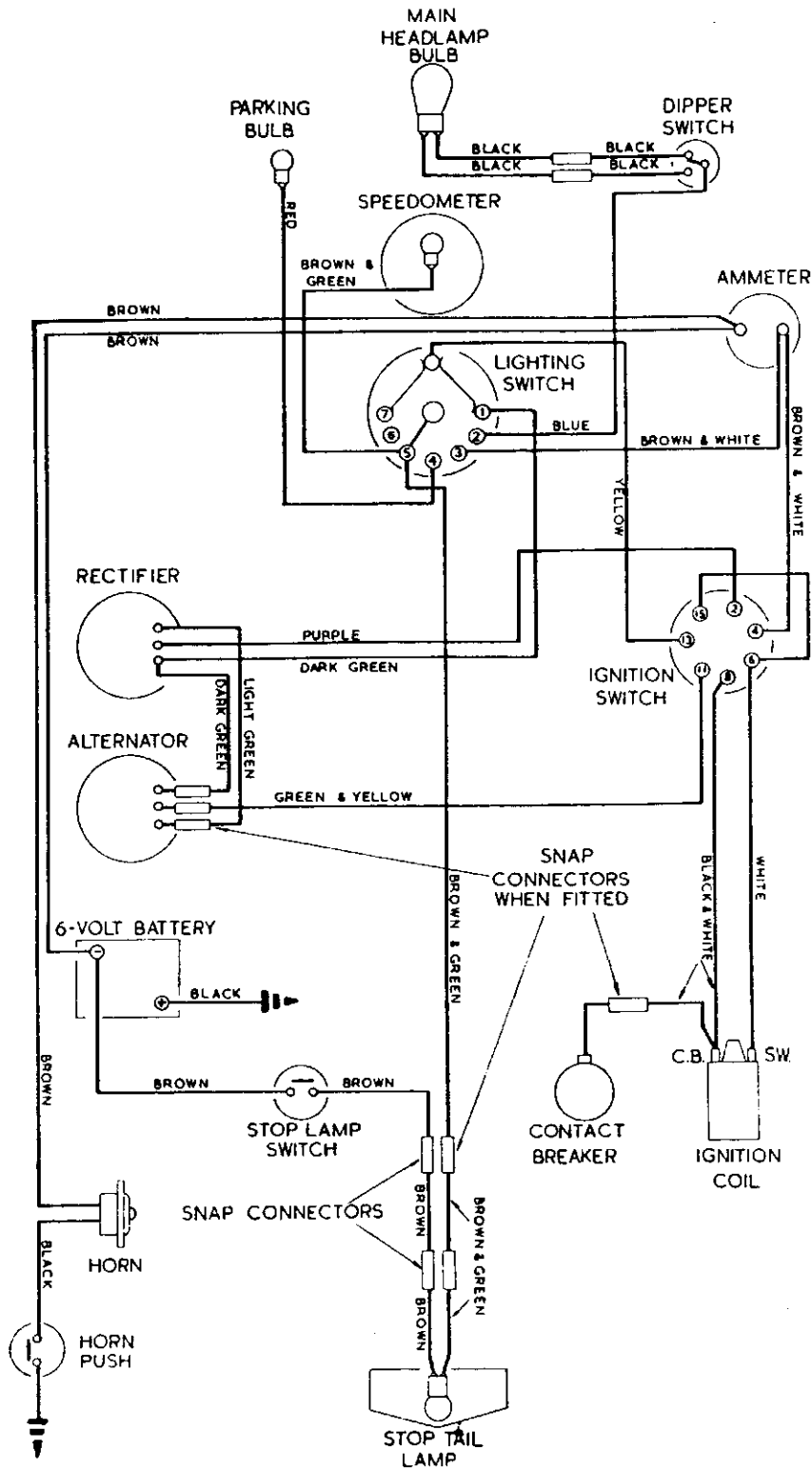

WIRING LAYOUT DIAGRAM

RM14 — Separate Lighting-Ignition Switch Circuit for use on Twin Cylinder Machines

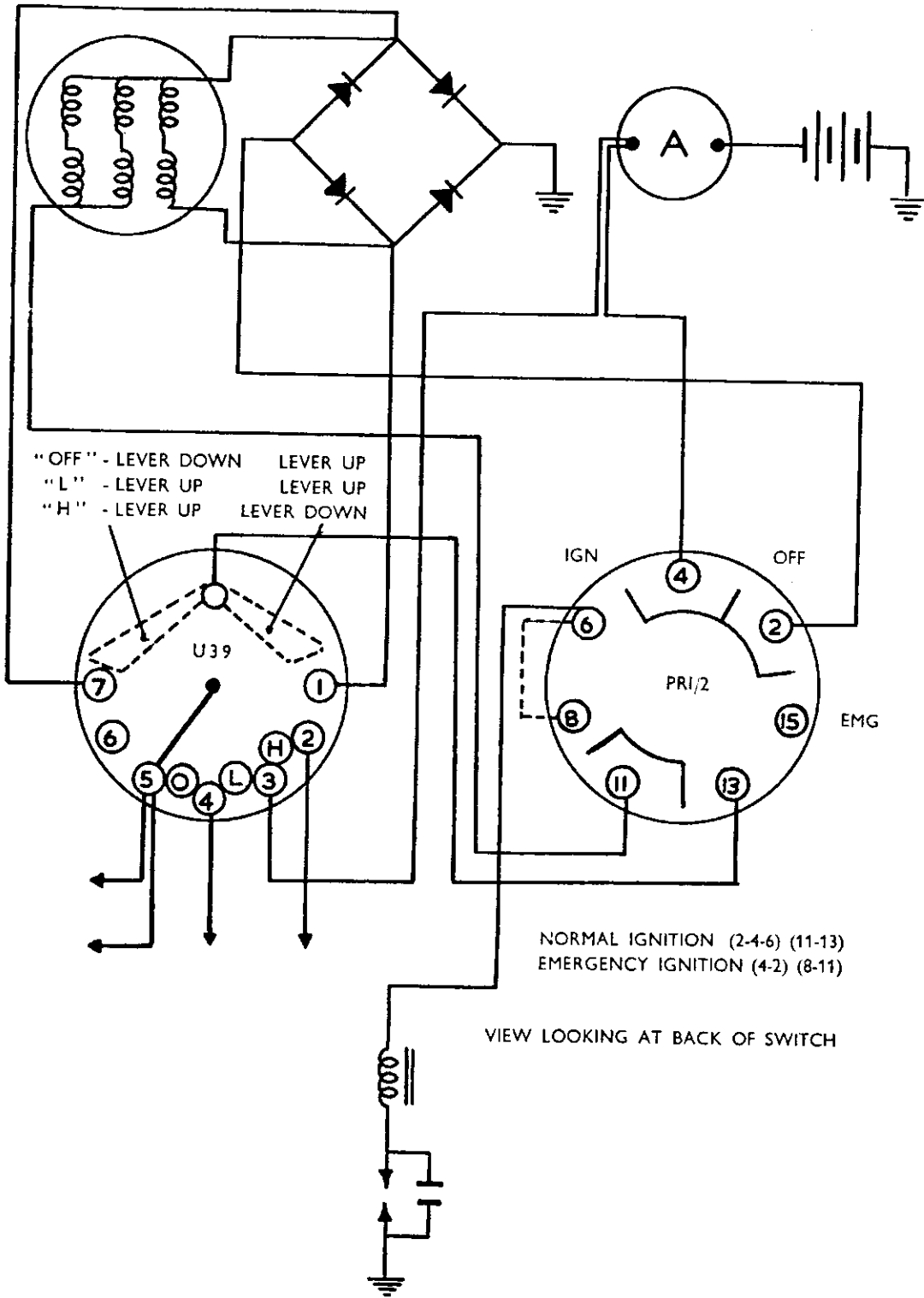

THEORETICAL DIAGRAM

RM13 or RM14 — Circuit used on Single or Twin Cylinder Machines using Magneto Ignition

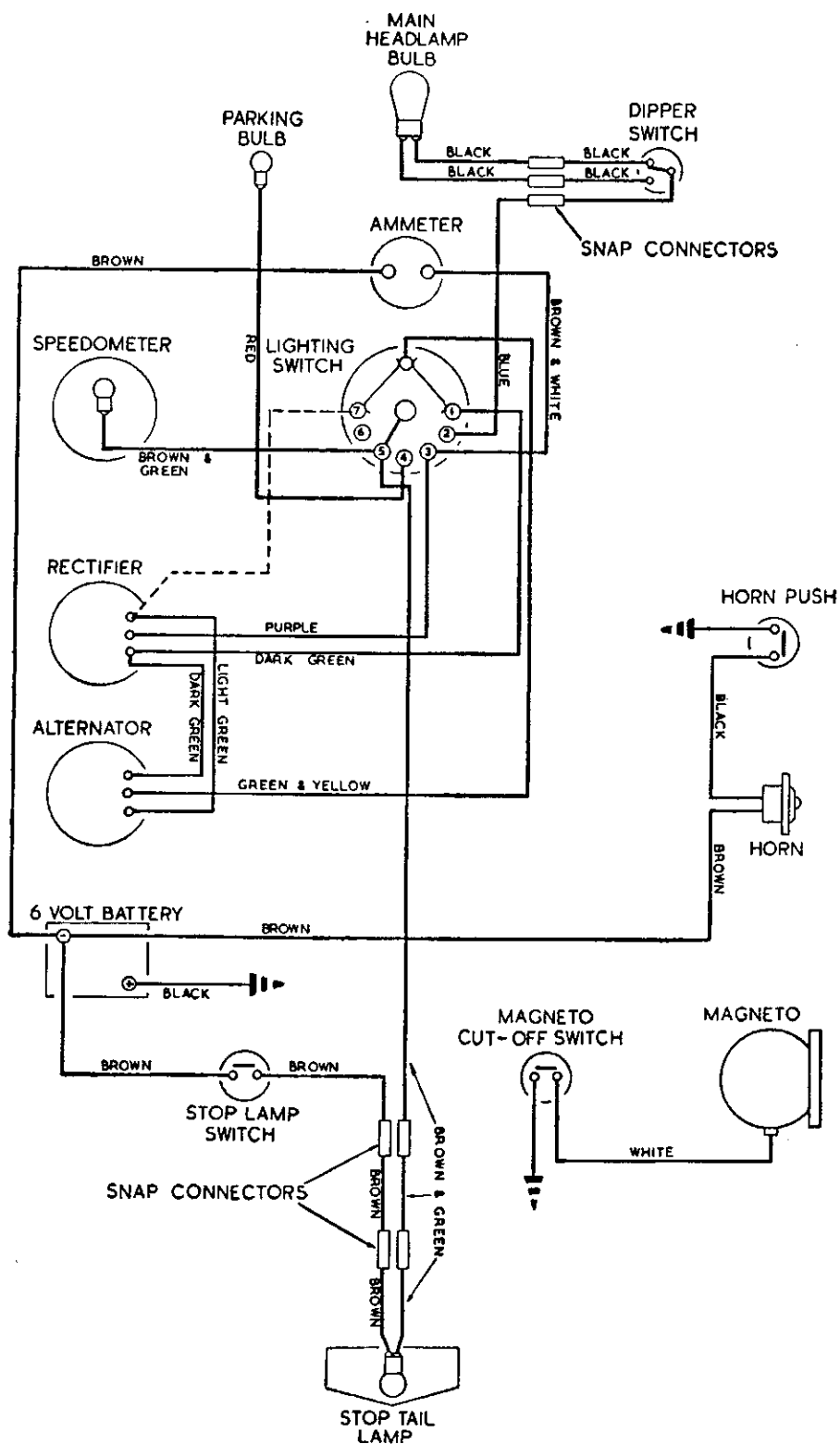

NOTE:
When this circuit is used on Twin-Cylinder machines a lead is included between terminal 7 on the lighting switch, and the Light Green terminal at the rectifier.

WIRING LAYOUT DIAGRAM

Typical Two Charge Rate Control Circuit for a Twin Cylinder Machine

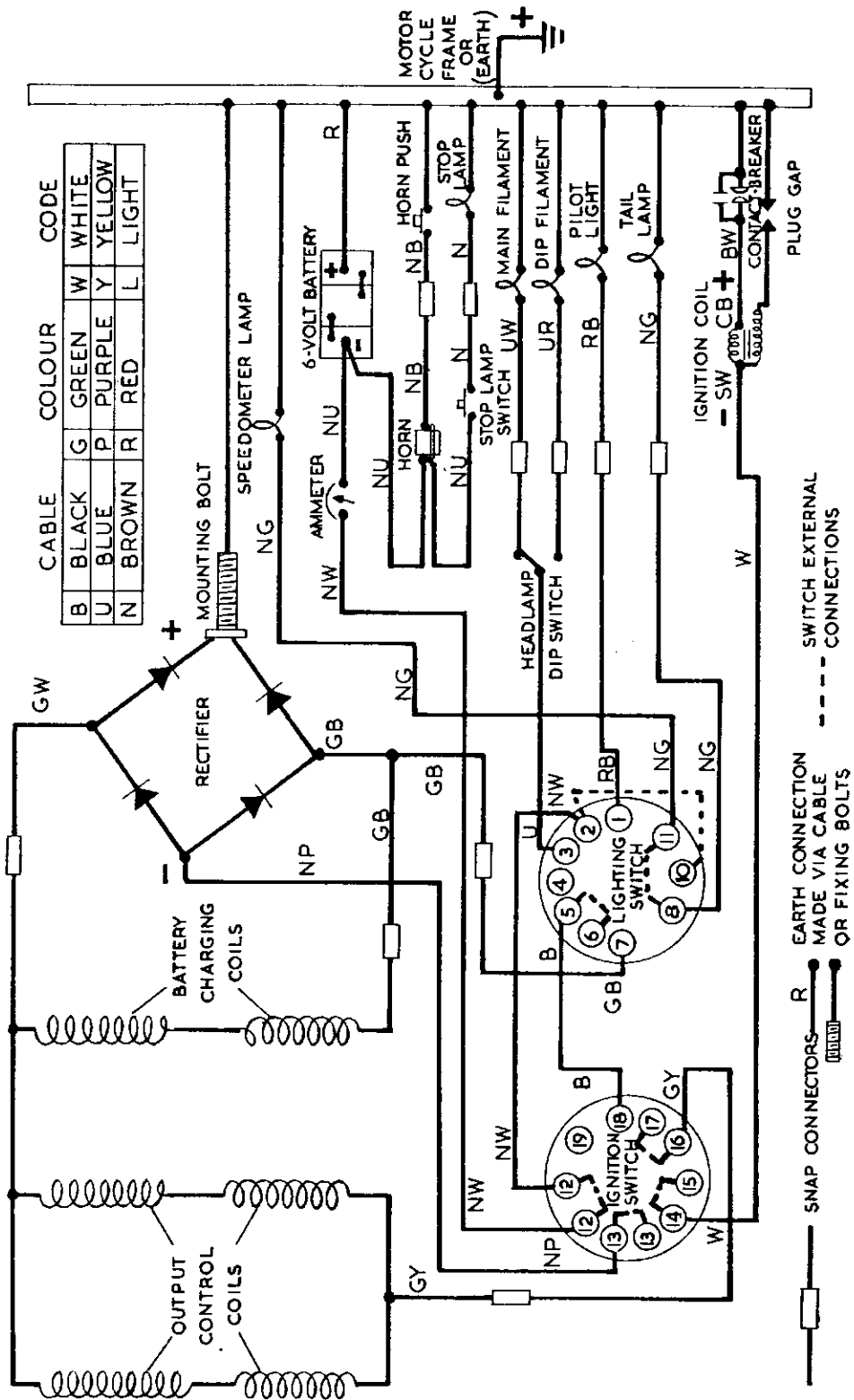

Arrangement of Internal and External Connections for 63SA and 88SA Lighting and Ignition Switches

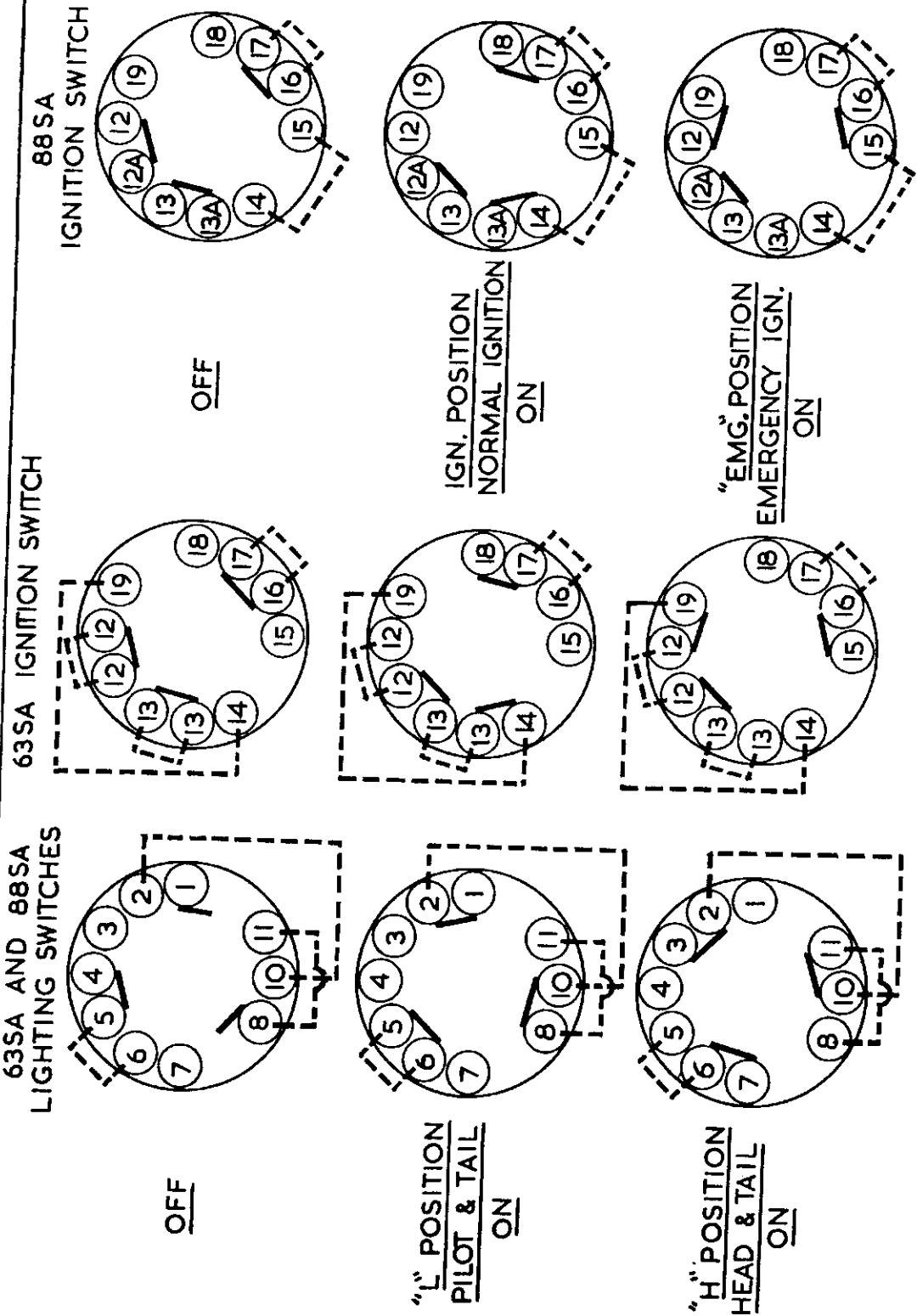

63SA & 88SA SWITCH ROTOR POSITIONS & SWITCH LINKS, VIEWED FROM REAR OF SWITCHES. EXTERNAL SWITCH LINKS ARE SHOWN AS DOTTED LINES.

Typical Wiring Circuit for A.C. Ignition and Direct Lighting Systems

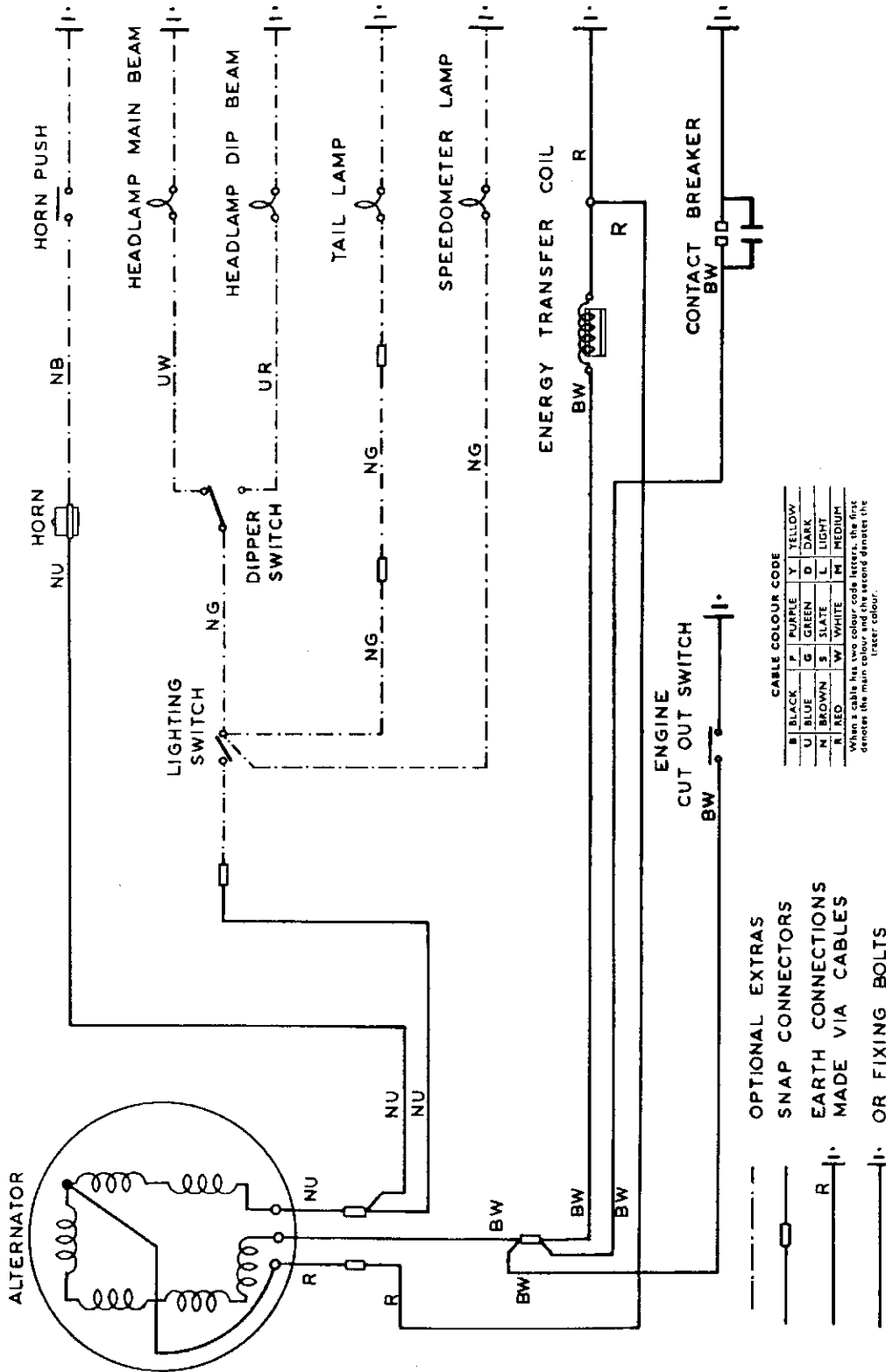

This system incorporates A.C. ignition and direct lighting. Four alternator coils provide A.C. current for the energy transfer ignition coil. Two coils provide current A.C. for lighting equipment which is optional. The ignition coil is a special "energy transfer" type. This type of circuit is frequently used on trials and scrambles machines, etc.

Typical Wiring Circuit for Zener Diode Charge Control System with Twin-Coil Ignition and Twin Contact-Breakers

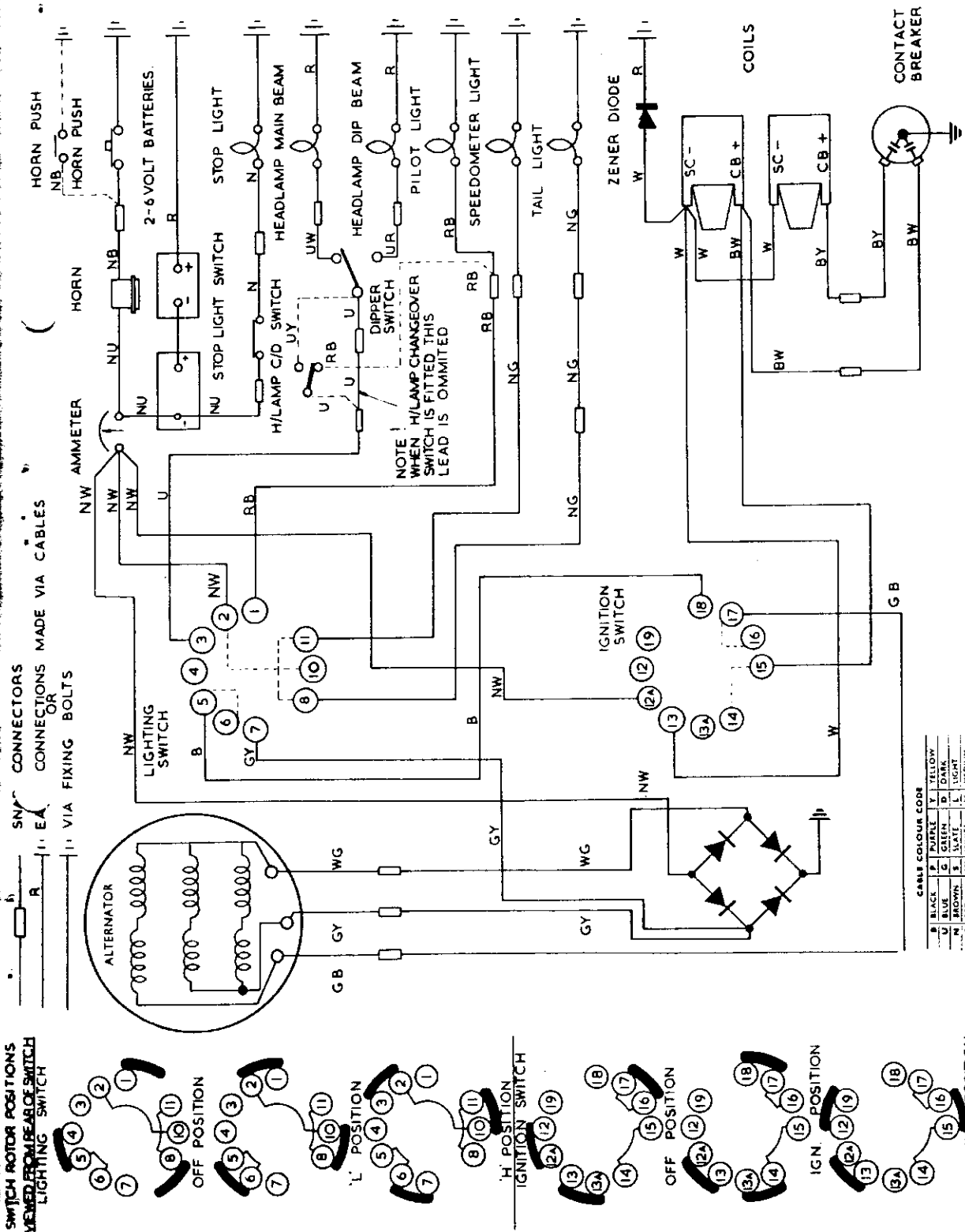

This system incorporates Zener Diode Charge Control and Twin-coil, Twin-contact breaker A.C. ignition. Four charging coils are permanently connected across the rectifier in the "off" and "pilot" position for battery charging. Overcharging is eliminated due to the function of the Zener Diode (connected in parallel with the battery), which bypasses part of the charging current when the batteries are in a fully charged condition. The remaining two coils are brought into use when the headlamp is used to give maximum output from the alternator. For "emergency starting" the output from the two alternator coils, connected to Green/Black cable, is fed direct to the ignition coils. It should be noted that Zener Diode Charge Control is used only with 12-volt systems.

Typical Wiring Circuit for Three-Rate Charging System with Twin-Coil Ignition and Twin Contact-Breakers

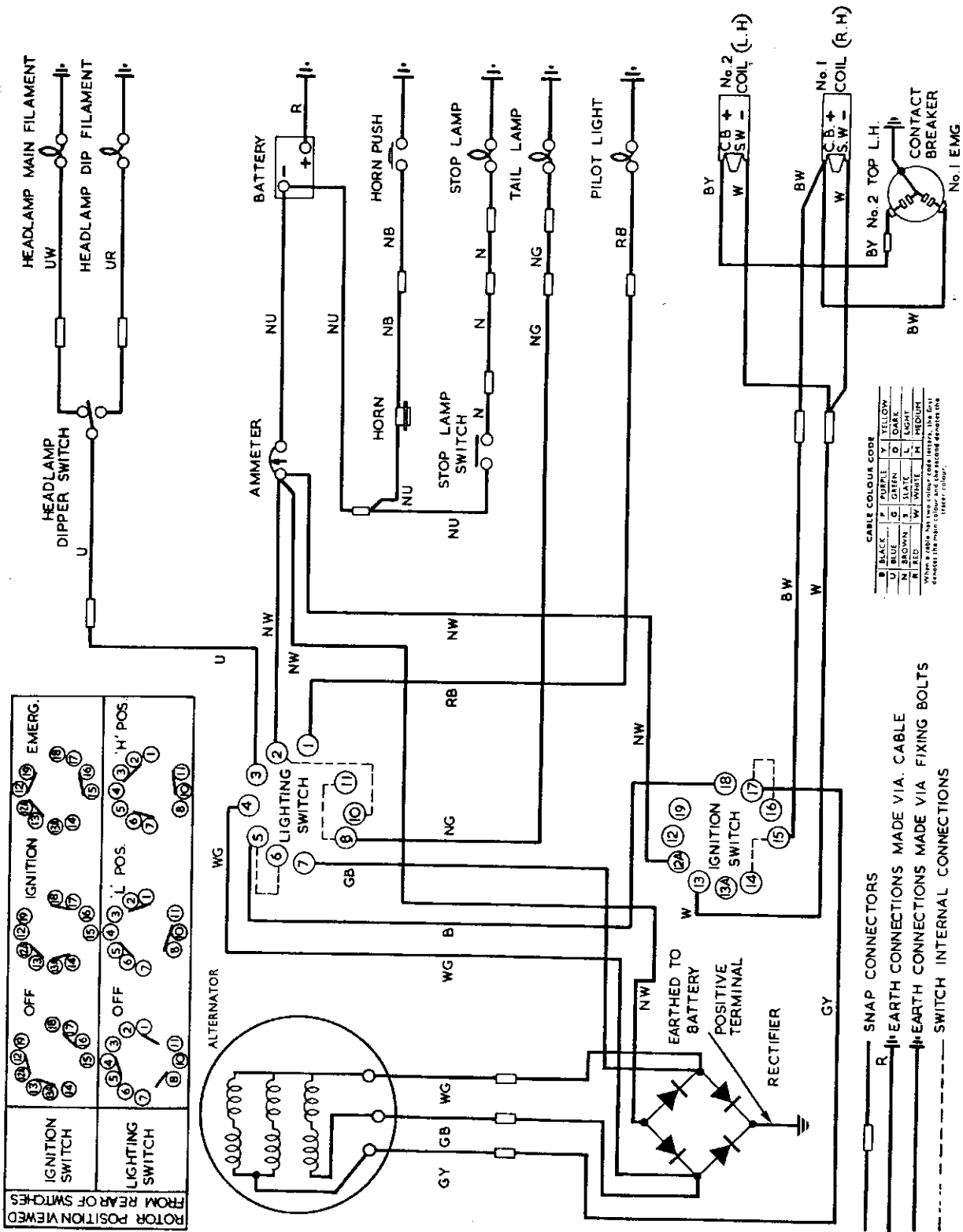

This system incorporates three-rate battery charging and an ammeter. Two alternator coils are permanently connected across the rectifier both in the "off" and "pilot" positions of the lighting switch. The control coils are short-circuited in the "off" position and open-circuited in the "pilot" position. All six coils are connected together when the headlamps are in use. The system also incorporates twin ignition coils and twin contact breakers. When starting on "emergency" ignition one of the ignition coils functions on the energy transfer principle, the other is eventually brought into use being supplied with current from the battery as it charges up, due to the permanently connected charging coils supplying sufficient energy for it to function in the conventional manner.

© 1964 The CD Motor Co. Ltd.

Typical Wiring Circuit for Three-Rate Charging System with Single Coil Ignition and Contact-Breaker

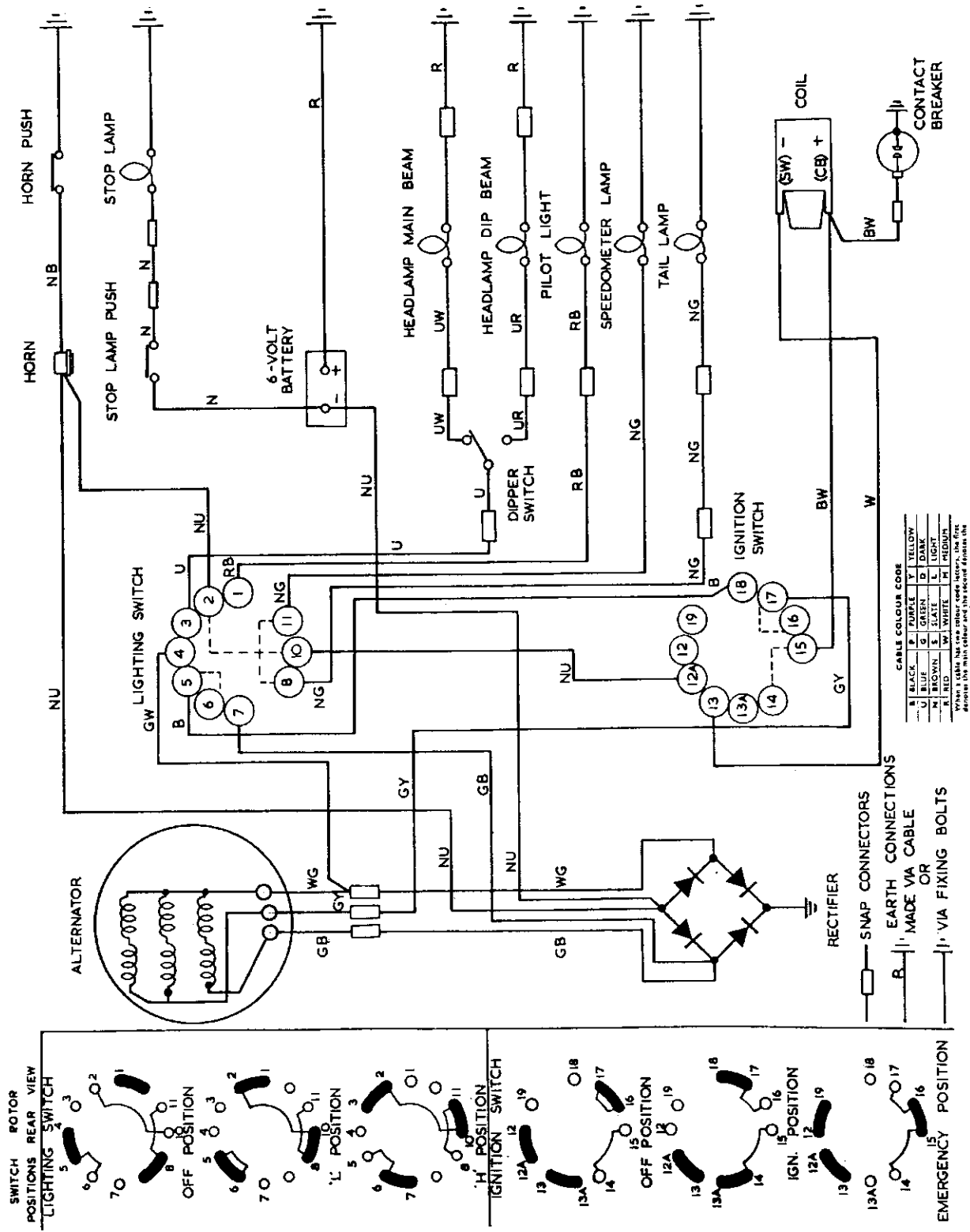

This system incorporates three-rate battery charging, two alternator coils being permanently connected across the rectifier, both in the "off" and "pilot" position of lighting switch. Six alternator coils are connected across the rectifier when headlamps are in use, so utilising full alternator output. Maximum alternator output is also available for "emergency" starting on the energy transfer principle. The control coils connected to the Green/Yellow cable are short-circuited in the "off" position of the lighting switch and open-circuited when the switch is in the "Pilot" position.

Typical Wiring Circuit for a 12-volt Two-Rate Charging System with Twin (series connected) Ignition Coils and Single Contact-Breaker

A Starting Motor and Flashing Light Indicators are also incorporated

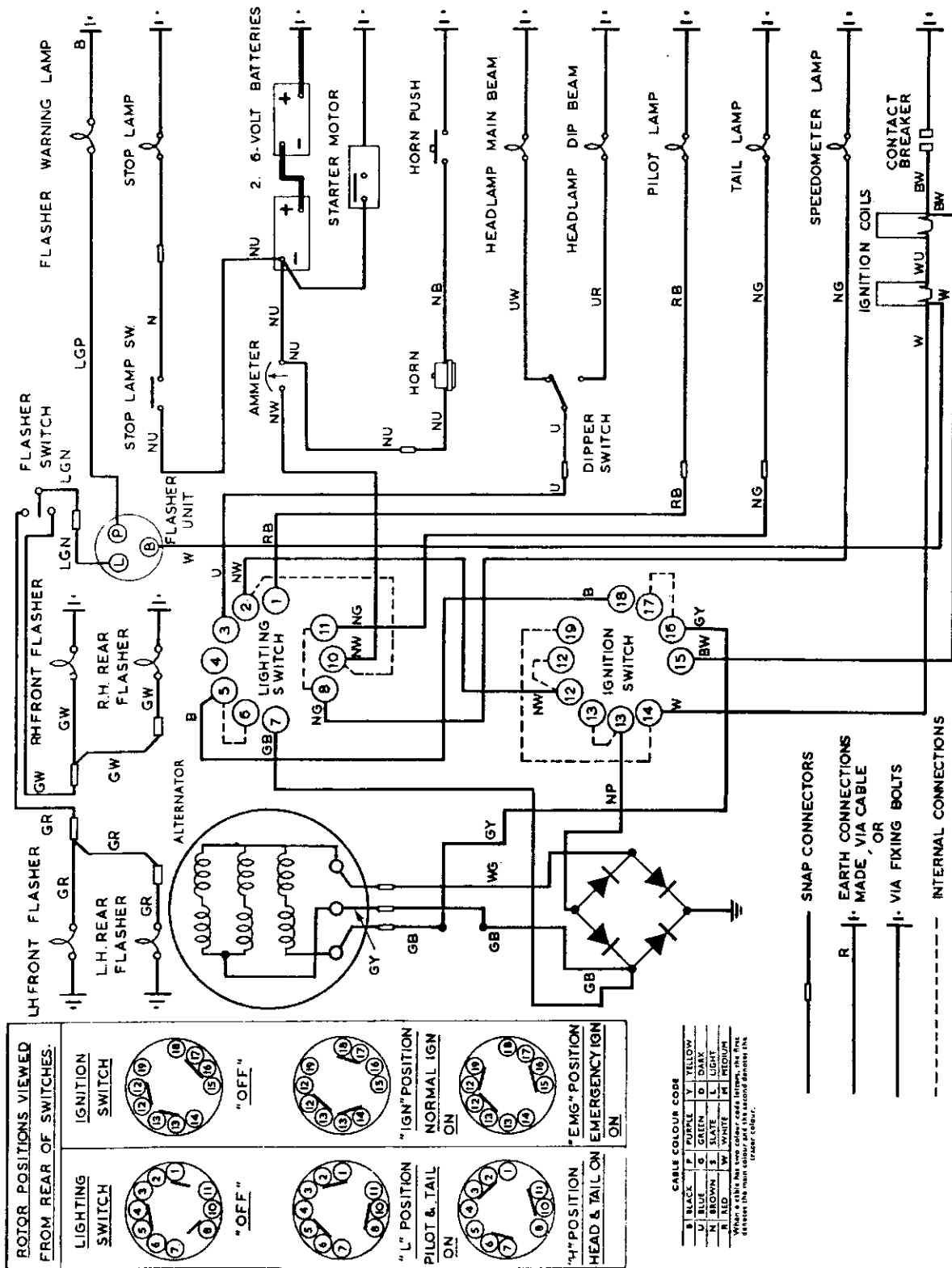

FLASHERS NOT FITTED TO EARLIER MODELS

Four alternator coils are permanently connected for battery charging, the two remaining coils supply the two (series connected) ignition coils. Only one contact-breaker is used. The two alternator ignition coils supply the twin ignition coils when "Emg." position is used.

Typical Wiring Circuit for Police and A.A. Machines with Maximum Charge ("Booster") Switch—Twin Ignition Coils and Contact-Breakers

PART 8

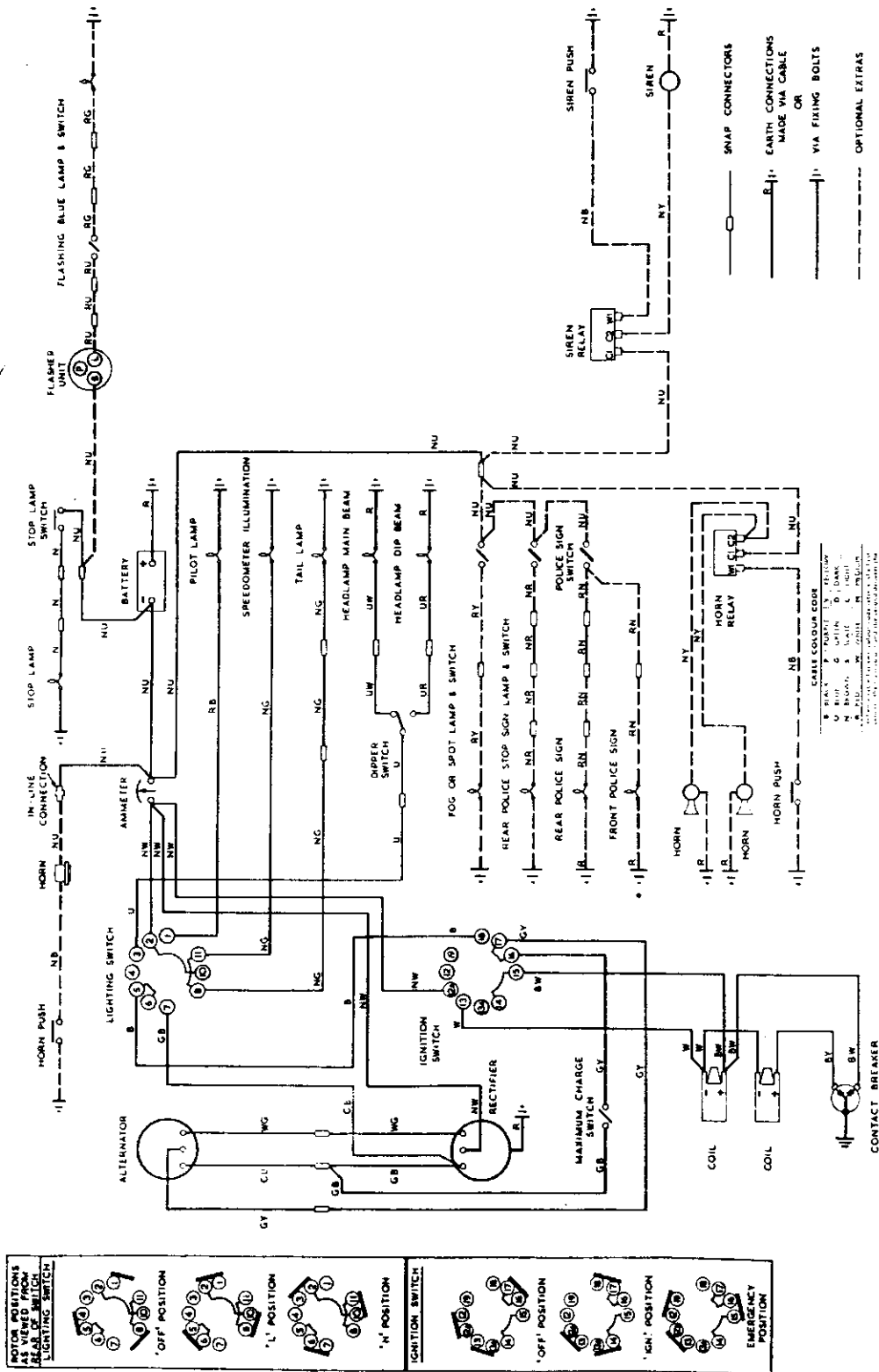

The alternator is connected to give a two rate charge, as for standard machines. Additional control of the alternator output is provided for by the inclusion of a maximum charge or "booster" switch, which when closed connects together the Green/Black and Green/Yellow cables, thereby causing the alternator to produce its full output. Although the switch can be operated at any time when the machine is in use, in practice it should only be used when it is required to bring a battery quickly up to a fully charged condition after a heavy current drain. It is not intended that it should be used continuously in circuit, as the battery may be damaged due to overcharging.

Typical Wiring Circuit for Twin-Cylinder A.C. Ignition with Twin-Energy Transfer Ignition Coils and Double Contact-Breakers —No Lights

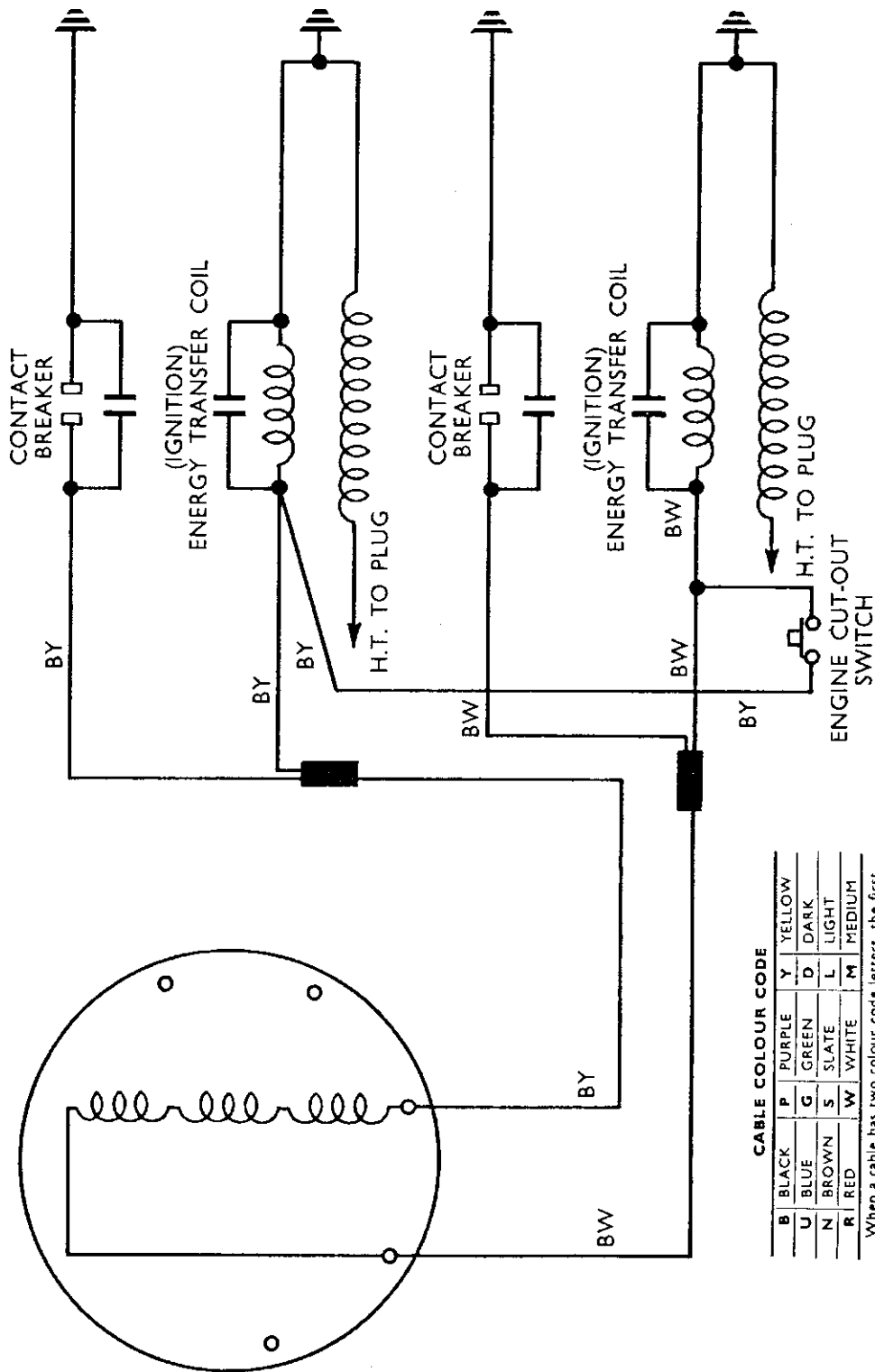

Three alternator ignition coils supply A.C. current to the two energy-transfer ignition coils. An engine cut-out switch is incorporated. The alternator in this type of system is an encapsulated RM19 unit.

Typical Wiring Circuit for Single Cylinder A.C. Ignition with Single Energy Transfer Ignition Coil — Provision for Direct A.C. Lighting with Stoplamp

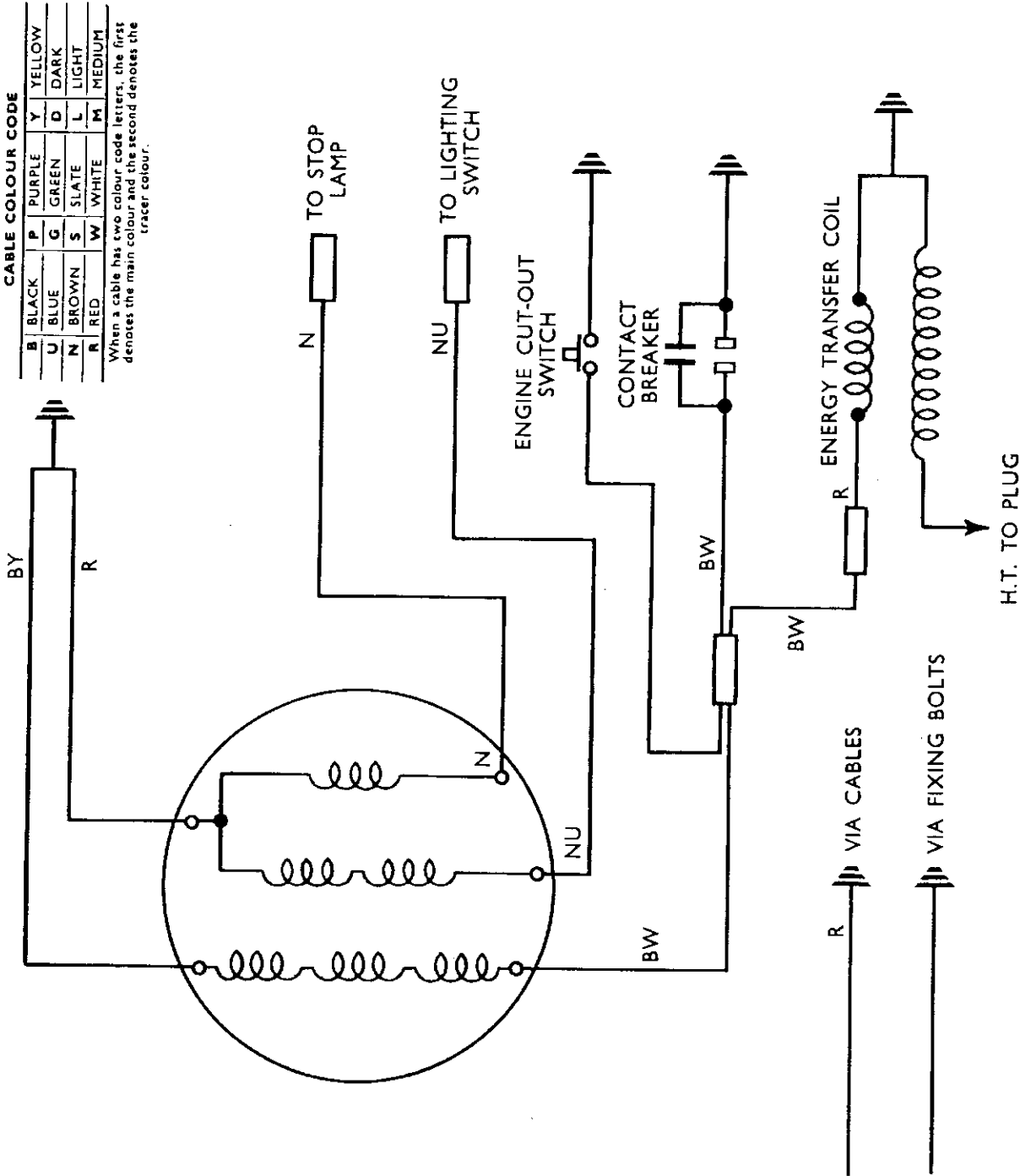

This circuit shows the connections for A.C. ignition using a single energy-transfer coil and single contact-breaker. Frequently used on scrambles machines, it can also be used on trials machines which require full lighting equipment, as separate lighting coils provide for direct (A.C.) lighting.

Zener Diode Charge Control Circuit with Alternator Permanently Connected for Full Output

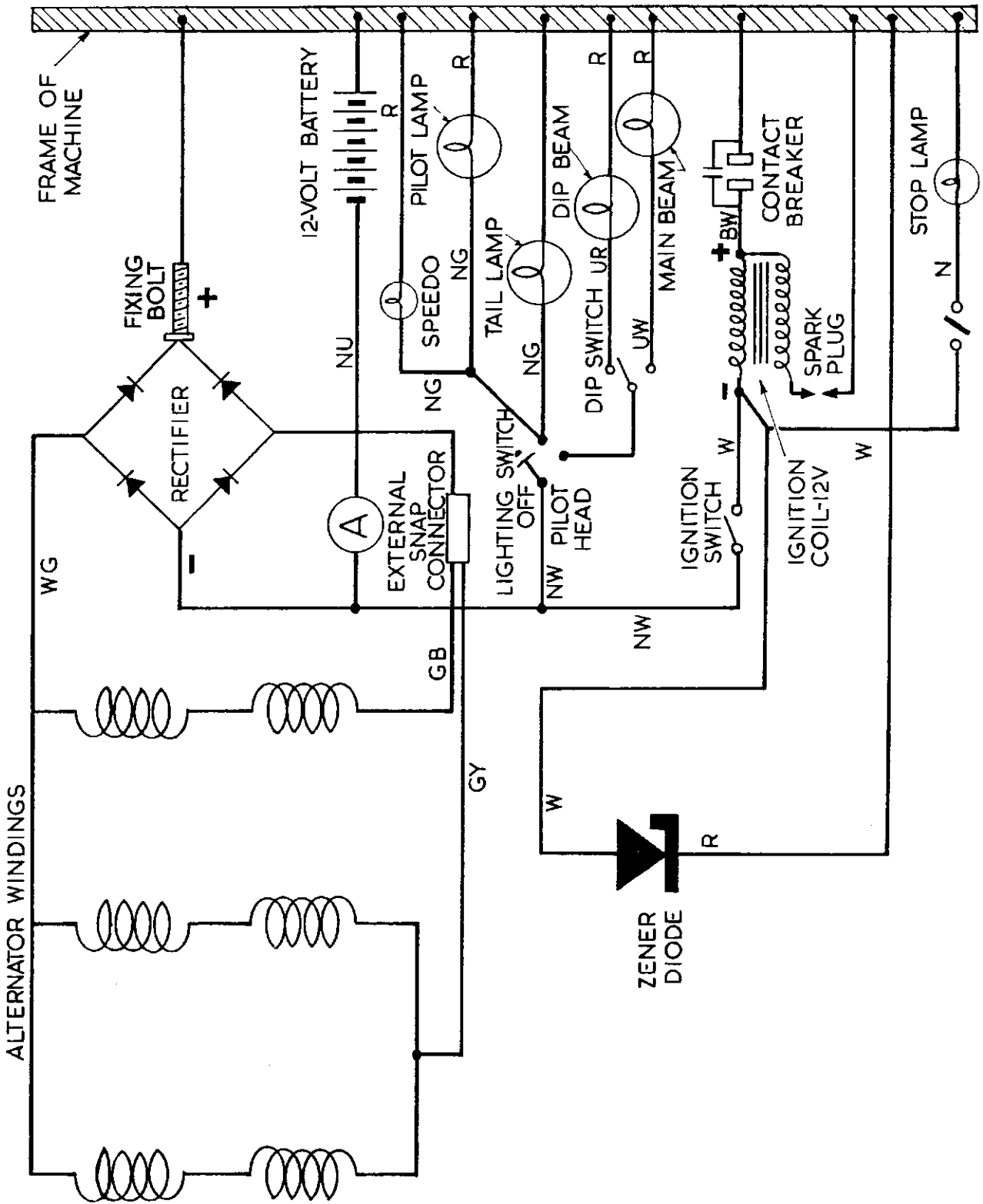

Alternator windings are connected (externally) to give continuous full output irrespective of position of lighting switch. Charging current to battery is controlled by a Zener Diode. This arrangement allows for a more simplified switching and wiring circuit as compared to earlier systems.

Typical Wiring Circuit for Twin Cylinder A.C. Ignition with Twin Energy Transfer Ignition Coils and Double Contact-Breakers — Full Direct A.C. Lighting Equipment. PART 8

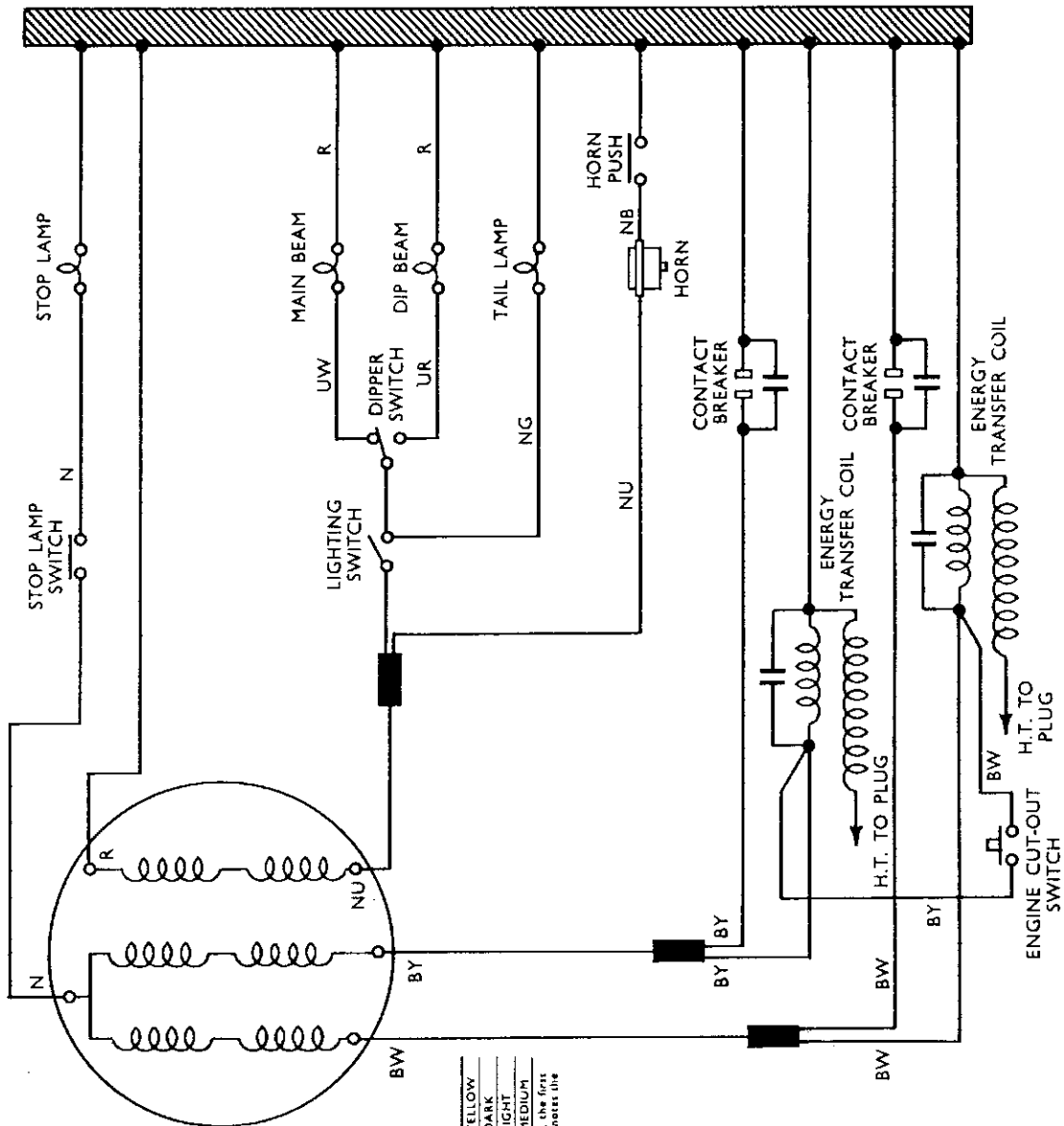

CABLE COLOUR CODE

B	BLACK	P	PURPLE	Y	YELLOW
U	BLUE	G	GREEN	D	DARK
N	BROWN	S	SLATE	L	LIGHT
R	RED	W	WHITE	M	MEDIUM

When a table has two colour code letters, the first denotes the main colour and the second denotes the tracer colour.

This circuit shows the connections for A.C. ignition using special energy transfer ignition coils and double contact-breakers. Separate lights and coil provide for full (direct) lighting equipment.

TEST DATA FOR LUCAS MOTORCYCLE ALTERNATORS

CHECKING THE ALTERNATOR ON THE MACHINE—USING AN

RM13—RM13/15—5AF (6-volt)

TEST	Voltmeter and Resistor Connected Across	Readings in Volts at 3,000 rev/min	
		RM13 — RM13/15 5AF (6-volt)	
1	GREEN/WHITE AND GREEN/BLACK	3.0 min	
2	GREEN/WHITE AND GREEN/YELLOW	6.0 min	
3	GREEN/WHITE AND GREEN/BLACK GREEN/YELLOW } Joined together	8.5 min	
4	ANY ONE LEAD AND STATOR (EARTH)	No Reading	

RM18

Voltmeter and Resistor Connected Across	Readings in Volts at 3,000 rev/min	
	Stator No. 47161A	Stator No. 47161B
WHITE/GREEN AND GREEN/BLACK	4.0 min	4.0 min
WHITE/GREEN AND GREEN/YELLOW	6.5 min	6.0 min
WHITE/GREEN AND GREEN/BLACK GREEN/YELLOW } Joined together	8.75 min	8.0 min
ANY ONE LEAD AND STATOR (EARTH)	No Reading	No Reading

RM14—RM15—5AF (12-volt)

TEST	Voltmeter and Resistor Connected Across	Readings in Volts at 3,000 rev/min	
		RM14 RM15	5AF (12-volt)
1	GREEN/WHITE AND GREEN/BLACK	4.0 min	3.5 min
2	GREEN/WHITE AND GREEN/YELLOW	6.5 min	5.5 min
3	GREEN/WHITE AND GREEN/BLACK GREEN/YELLOW } Joined together	9.0 min	7.0 min
4	ANY ONE LEAD AND STATOR (EARTH)	No Reading	No Reading

RM19 (A.C. Ignition without Battery)

Voltmeter and Resistor Connected Across	Readings in Volts at 3,000 rev/min		
	Stator No. 47173	Stator No. *47188	Stator No. 47197
BLACK/WHITE AND *BLACK/YELLOW	2.0 min	2.0 min	2.0 min
RED AND BROWN/BLUE	5.0 min	5.0 min	5.0 min
RED AND BROWN	4.0 min	4.0 min	5.0 min
ANY ONE LEAD AND STATOR (EARTH)	No Reading	No Reading	No Reading

* Black/White and Black/Yellow applies to Twin Cylinder machines — on Single Cylinder machines Black/Yellow becomes Red.

Note: If the engine will not start use a substitute ignition coil and battery to enable testing. Voltage across Red and Black/White, 2.0 volts min. If satisfactory check ignition timing, etc.

RM20/19—RM13/15—5AF—RM15 (High Output Alternators) Fitted to Two-way Radio-Equipped Machines

TEST	Voltmeter and Resistor Connected Across	Readings in Volts at 3,000 rev/min			
		RM13/15	5AF	RM15	RM20/19 Stator No. 47167
1	WHITE/GREEN AND GREEN/BLACK	6.5 min	6.0 min	9.0 min	8.5 min
2	WHITE/GREEN AND GREEN/YELLOW	9.5 min	9.0 min	12.0 min	11.5 min
3	WHITE/GREEN AND GREEN/BLACK GREEN/YELLOW } Joined together	13.0 min	11.0 min	15.0 min	13.5 min
4	ANY ONE LEAD AND STATOR (EARTH)	No Reading	No Reading	No Reading	No Reading

ALTERNATORS

MODELS

RM13	RM13/15	RM14
RM15	RM18	RM19
5AF	RM20/19	9AF
(6 and 12-volt)		

A.C. VOLTMETER AND 1 OHM LOAD RESISTOR

RM19—9AF

Voltmeter and Resistor Connected Across	Readings in Volts at 3,000 rev/min					
	Stator No. 47162	*Stator No. 47164	*Stator No. 47179	Stator No. 47181	Stator No. 47182	Stator No. 47183
WHITE/GREEN AND GREEN/BLACK	4.0 min	4.5 min	4.0 min	4.5 min	2.0 min	2.0 min
WHITE/GREEN AND GREEN/YELLOW	6.5 min	7.0 min	6.5 min	7.0 min	7.0 min	7.0 min
WHITE/GREEN AND GREEN/BLACK AND GREEN/YELLOW } Joined together	8.5 min	9.5 min	8.5 min	9.5 min	7.5 min	7.5 min
ANY ONE LEAD AND STATOR (EARTH)	No Reading	No Reading	No Reading	No Reading	No Reading	No Reading

* These stators are also used with 9AF Alternators.

RM15 (A.C. Ignition without Battery)

Voltmeter and Resistor Connected Across	Readings in Volts at 3,000 rev/min
GREEN/WHITE AND GREEN/BLACK	5.0 min
GREEN/WHITE AND GREEN/YELLOW	5.0 min
GREEN/WHITE AND GREEN/BLACK AND GREEN/YELLOW } Joined together	9.0 min
ANY ONE LEAD AND STATOR (EARTH)	No Reading

RM13 (A.C. Ignition with Battery)

Voltmeter and Resistor Connected Across	Readings in Volts at 3,000 rev/min
RED AND BROWN/BLUE	5.0 min
RED AND BLACK/WHITE	1.5 min
RED AND BROWN (When fitted)	3.5 min
ANY ONE LEAD AND STATOR (EARTH)	No Reading

Note: If the engine will not start use a substitute battery and ignition coil to enable testing. If the engine still will not start check ignition timing, etc.

CHECKING D.C. CURRENT AT THE RECTIFIER

(If Zener Diode is used for charge control it must be disconnected before commencing the tests)

RM13—RM13/15—RM14—RM15—
SAF (6 and 12-volt)

LIGHTING SWITCH POSITIONS	Readings in Amps. at 3,000 rev/min	SAF (12-volt)
RM13 RM13/15 SAF (6-volt)	RM14 RM15	
OFF	1.5 min	2.5 min
PILOT	1.5 min	2.0 min
HEAD	3.0 min	3.25 min
		6.0 min

RM13/15—RM15—SAF—RM20/19
(High Output Machines)

LIGHTING AND "BOOSTER" SWITCH POSITIONS	Readings in Amps. at 3,000 rev/min	RM20/19 Stator No. 47167
OFF	5.0 min	4.0 min
"BOOST" SWITCH IN	9.0 min	9.0 min
PILOT	4.0 min	2.5 min
"BOOST" SWITCH IN	7.0 min	7.0 min
HEAD	4.0 min	3.5 min
"BOOST" SWITCH IN	4.0 min	3.5 min
		13.5 min

RM18

Readings in Amps. at 3,000 rev/min	
Stator No. 47161A	Stator No. 47161B
2.5 min	2.5 min
2.0 min	1.5 min
3.0 min	2.0 min

RM19—9AF

Readings in Amps. at 3,000 rev/min					
Stator No. 47162	Stator No. 47164	Stator No. 47179	Stator No. 47181	Stator No. 47182	Stator No. 47183
2.5 min	2.5 min	2.5 min	2.5 min	2.5 min	1.25 min
2.0 min	0.5 min	2.0 min	2.0 min	2.0 min	2.0 min
1.75 min	1.5 min	1.75 min	1.5 min	1.75 min	0.5 min
					Load Balanced

Service Notes: The output figures given in the above charts relate to machines connected to give the standard 3-rate charge control. However, some production machines and a great many others since going into service, have been modified to give a 2-rate charge control to compensate for abnormal service conditions. Also, some machines incorporate a Zener Diode charge control system, for which 4 of the alternator coils are permanently connected across the rectifier, instead of 2 coils as in the standard 2 and 3-rate charge systems. In the latest Zener Diode control system all six coils are connected to give full output irrespective of lighting switch position.

Therefore, before checking the alternator output, ascertain what type of system is in use on the machine to be serviced, so that any difference between Test ammeter readings and those given in the above charts can be taken into account.