

Pazon
IGNITIONS WITH THE 7½ YEAR WARRANTY

Smart-Fire™

TRIUMPH **BSA** **Norton**

UNIT TWIN

TWINPLUG HEAD

**HIGH-PERFORMANCE
IGNITION SYSTEM**

12 VOLT POS/NEG GROUND

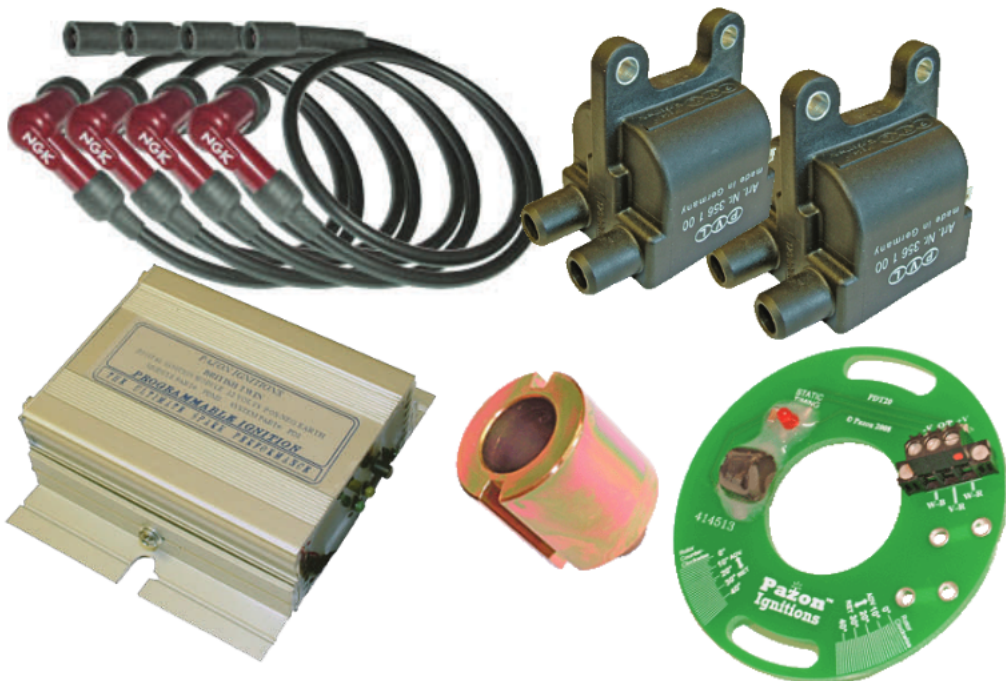

SYSTEM TYPE: PD2TP

Smart-Fire Applications

- TRIUMPH/BSA/NORTON UNIT TWIN WITH TWINPLUG HEAD CONVERSION (ALL MODELS, INCL E-START) & 12 VOLT ELECTRICS, POSITIVE OR NEGATIVE GROUND

FEATURES

- HIGH-POWER DIGITAL IGNITION MODULE (FULLY ENCAPSULATED)
- FULLY MAPPED IGNITION TIMING & PROGRAMMED COIL ENERGY CONTROL FOR TWINPLUG HEAD ENGINE
- USER-PROGRAMMABLE REV.LIMITER BUTTON
- RELIABLE & RUGGED HALL-EFFECT SENSOR, INCLUDES ON-BOARD STATIC TIMING LIGHT, FOR EASY SETTING OF IGNITION TIMING
- MINIATURE HIGH-ENERGY DUAL IGNITION COILS
- ELECTRONIC TACHO DRIVE OUTPUT
- WASTED SPARK SYSTEM FOR SIMPLICITY
- LESS MAINTENANCE
- IMPROVED ENGINE PERFORMANCE
- FOR RACING OR HIGHLY TUNED APPLICATIONS: SPECIAL ADVANCE CURVES & REV-LIMITERS AVAILABLE
- COVERED BY MANUFACTURER'S 7½ YEAR WARRANTY
- MODULE SIZE(mm):
90 LONG x 65 WIDE (95 INC. MOUNTING BRACKETS)
x 30 DEEP, WEIGHT: 400g (INC. WIRES)

IGNITION SYSTEM COMPRISES:

- IGNITION MODULE (ALUMINIUM HOUSING WITH MOUNTING BRACKETS) & WIRING
- DIGITAL HALL-EFFECT TRIGGER UNIT
- ELECTROPLATED STEEL ROTOR, 1/4" FIXING BOLTS (BSF & UNF) & WASHER
- TWO DIGITAL IGNITION COILS (DUAL OUTPUT)
- FOUR H.T. LEADS (COPPER-CORED)
- FOUR PLUG CAPS (5K RESISTOR TYPE)
- FIXING SCREWS, WASHERS & NUTS
- CRIMP TERMINAL CONNECTORS & INSULATORS
- RED GROUNDING WIRE, BLACK IGNITION COIL LINK WIRE
- LARGE & SMALL CABLE TIE-STRAPS

Smart-Fire Fitting Instructions

**WARNING: THIS SYSTEM PRODUCES VERY HIGH VOLTAGES,
ALWAYS SWITCH OFF BEFORE WORKING ON THE SYSTEM.**

IMPORTANT NOTES:

BEFORE FITTING, PLEASE READ THESE INSTRUCTIONS CAREFULLY, INCLUDING THE NOTICE ON PAGE 16.

This system is designed to work only with the special digital ignition coil provided with the system. 5K resistor plug caps as supplied with the system should be fitted to the h.t. leads. Alternatively, resistor spark plugs can be used. Resistor plugs & resistor caps can be used, although it is not necessary to use both. Attempting to run the system without resistor type caps or plugs will result in excessive radio frequency interference (r.f.i.), which may cause bad running, misfiring and loss of ignition. For reliability, copper or steel cored h.t. leads should be used, we do not recommend using carbon fibre leads. This ignition is a wasted spark system, therefore all plugs fire at the same time.

These instructions are a general guide for installing the system to various machines and therefore it may be necessary to modify the length or routing of some wires in order to complete the installation. All connections should be made using good quality crimped or soldered connections; twisted wires will not give satisfactory operation. Wiring should be trimmed to the correct length, excess wire should not be coiled up as this can affect the correct running of the ignition system. If electric welding is to be carried out, the ignition module should be disconnected and its connectors covered with insulation, to help prevent stray sparks from damaging the module. If in doubt, remove the unit from the machine.

1. For safety, disconnect the battery (preferably both terminals).
2. Remove the timing cover (the Atlas engine has the points housing behind the cylinder head).
3. Disconnect the wires from the contact-breaker assembly. Remove the contact-breaker/condenser assembly; retain the fixing screws for later.
4. Remove the auto-advance mechanism.
5. Remove the petrol tank and/or seat to gain access to the ignition

coils, condensers and wiring.

6. Make a note of all existing wire colours & connections on the ignition coils. Remove the two wires & sleeving that connected between the coils & contact-breakers (usually coloured black/white & black/yellow). Disconnect the remaining wires from the ignition coils. These come from the ignition switch supply. The colour of this ignition supply wire may vary between machines; check using a test lamp or meter to find the live wire when the ignition is switched on.
7. Remove the coils, h.t. leads & any mounting brackets. The condensers are no longer required & can be removed.
8. Fit the ignition module in a convenient place. This could be under (or on the side of) the battery platform, inside the toolbox (if available) or secured to the frame using a suitable mounting bracket. The unit can be orientated in any position, but this should be onto a flat surface, if possible. The module can be secured by the mounting flanges using the two M5 bolts, washers & nuts. Alternatively, the mounting flanges can be removed by slackening the bracket securing screws and sliding the brackets out of the dovetail slots. The module can then be mounted using large tie-straps, with a small sheet of rubber between the case & the frame.
9. Fit the ignition coils in a convenient place. Suspend each coil by the two mounting lugs, using the M5 bolts, washers & nuts. Alternatively, to avoid the need for drilling or a mounting bracket, the coils can be rubber mounted using two small pieces of rubber tubing (such as fuel pipe or heater hose) & two large tie-straps, see figs. 1 / 1a. The coils can then be secured to the frame tube by fully tightening the tie-straps. Fit the new h.t. leads by pushing the brass connectors fully into the h.t. outlets of the coil, along with the rubber boots. Small tie-straps can be placed around the rubber boots & tightened to give extra security, if desired. **The h.t. leads should be arranged so that each coil fires across both cylinders (see wiring schematics on pages 8-9).** The h.t. leads should now be cut to length, if necessary, & the plug caps screwed onto the ends of the h.t. leads. Push the plug caps onto the plugs (either way around), they should click into place.



FIG. 1



FIG. 1a

10. Remove timing inspection cover from alternator side of engine. Set the engine to the full advance timing mark on the compression stroke (note: the other cylinder will be on the exhaust stroke). Either cylinder can be used, since both fire together (wasted spark system). If a timing mark is unavailable, the engine will need to be set using either a dial guage down the bore or a degree disc. Note: if using a degree disc attached to the camshaft, the full advance figure on the disc must be halved, e.g. for 32° , set the engine to TDC, zero the degree disc and rotate engine backwards until the degree disc has travelled 16° . See Table 1 (page 11) for the recommended full advance figures for twinplug engines in a standard state of tune.
11. Take the ignition trigger assembly (round green printed circuit board) & pass a small tie-strap through one of the two sets of holes in front of the 3-way connector block; leave unfastened at this stage. The lower set of holes are for routing the wires through an aperture at approx 5 o'clock position (e.g. Triumph); the upper set are for routing the wires through an aperture at approx 3 o'clock position (e.g. Norton Commando). Fit the trigger assembly (connector block facing outwards) into the contact-breaker housing. Fit the pillar fixing screws removed in step 3, finger tighten so that the trigger can be turned by hand.
12. Fit the steel rotor into the end of the camshaft in the place of the auto-advance mechanism; it has a male taper that mates with the end of the camshaft. Determine the direction of rotation of the steel rotor (see Table 1, page 11) and rotate the trigger assembly as per fig. 2 (clockwise) or fig. 5 (counter-clockwise), pages 12-13.

Then, without turning the engine, set the rotor so that one of the two slots is positioned relative to the centre of the black sensor on the trigger as shown in fig.2 or fig. 5. Using one of the two bolts provided (Norton requires the BSF bolt, Triumph requires the UNF bolt), pass the 1/4" cap head screw & washer through the centre of the rotor & into the thread in the end of the camshaft; tighten the cap head screw. Recheck the rotor position. The rotor centre thread (metric M8) is provided for attaching a puller, if the rotor should need to be removed for engine servicing, etc.

WIRING *(PLEASE SEE WIRING SCHEMATICS ON PAGES 8 & 9)*

1. The ignition trigger wires (sleeved) are coloured: White—Black, Violet—Red & White—Red. Allowing some slack in the cable, route these wires from the ignition module down to the trigger in the points housing. If passing through holes in metalwork, use grommets or sleeving. Route the wires to the 3-way connector block. Allowing some movement in the cable (for setting the ignition timing), cut the cable & sleeving to length. Carefully strip back 4-5mm of insulation from the ends of the three wires. Insert the three wires into the connector block (from left to right) as follows: White—Black, Violet—Red, White—Red. Tighten the three screws with a small screwdriver. Secure the sleeved wires to the trigger plate with a small tie-strap, using the set of holes provided in front of the connector block; cut off the excess from the tie-straps.
2. Using the black coil link wire, connect the positive (+) terminal of ignition coil #1 to the negative (—) terminal of ignition coil #2. See pages 8 & 9.
3. Connect the violet wire from the ignition module to the negative (—) terminal (left-hand spade connector) of ignition coil #1, using a female crimp connector and insulating cover.
4. Connect the red wire from the ignition module to the positive (+) terminal (right-hand spade connector) of ignition coil #2, using a female piggyback crimp connector and insulating cover.

*Re-check the connections to the ignition coils;
reverse polarity may damage the coils.*

For **positive ground** electrics (standard), go to step 6.

5. For **negative ground** electrics (see page 8): connect the black wire from the ignition module to a good grounding point on the frame or directly to the battery negative (—), using a ring terminal. Connect the spare terminal on the piggyback connector (on the positive side of ignition coil #2), to a switched positive supply (+12 volts), preferably via a fuse (8-10 amp recommended) and through the ammeter, if fitted. Go to step 8.
6. For **positive ground** electrics (see page 9): connect the spare terminal on the piggyback connector (on the positive side of ignition coil #2), to a good grounding point on the frame or directly to the battery positive (+), using the red grounding wire provided. Connect this wire to the coil end using a female spade connector and insulating cover. Connect the other end to ground/battery positive using a ring terminal.
7. Connect the black wire from the ignition module, to a switched negative supply, preferably via a fuse (8-10 amp. recommended) and through the ammeter, if fitted.
8. Suggestions for the choice of switch can be a spare position on the headlamp switch (if available), a second dip switch on the handlebars or a key switch located in the headlamp shell. It is important that the switch is in good condition; corroded or dirty contacts will cause misfiring/cutting out.
9. The **ORANGE** wire is an IGNITION INHIBIT input, and only functions with NEGATIVE GROUND electrics.
This can be connected to a grounding kill switch or a hidden security switch. If not required, place insulating tape over the end of the wire to prevent accidental shorting out.
10. The **GREY** wire is a tacho output signal for driving an electronic tachometer, if fitted. This is a 12 volt output and provides 1 pulse per engine revolution. If your tacho requires a different pulse rate, contact Pazon Ignitions. Connect to the tacho signal input terminal/wire. If you have a mechanical tacho (or no tacho) then leave unconnected; cut short the wire & and insulate the wire end.
11. Any remaining wires which may be present on the ignition module are for factory use and should remain unconnected and insulated, as supplied.

**WARNING: TURN OFF/DISCONNECT THE BATTERY
BEFORE WORKING ON THE SYSTEM
HIGH VOLTAGES CAN KILL**

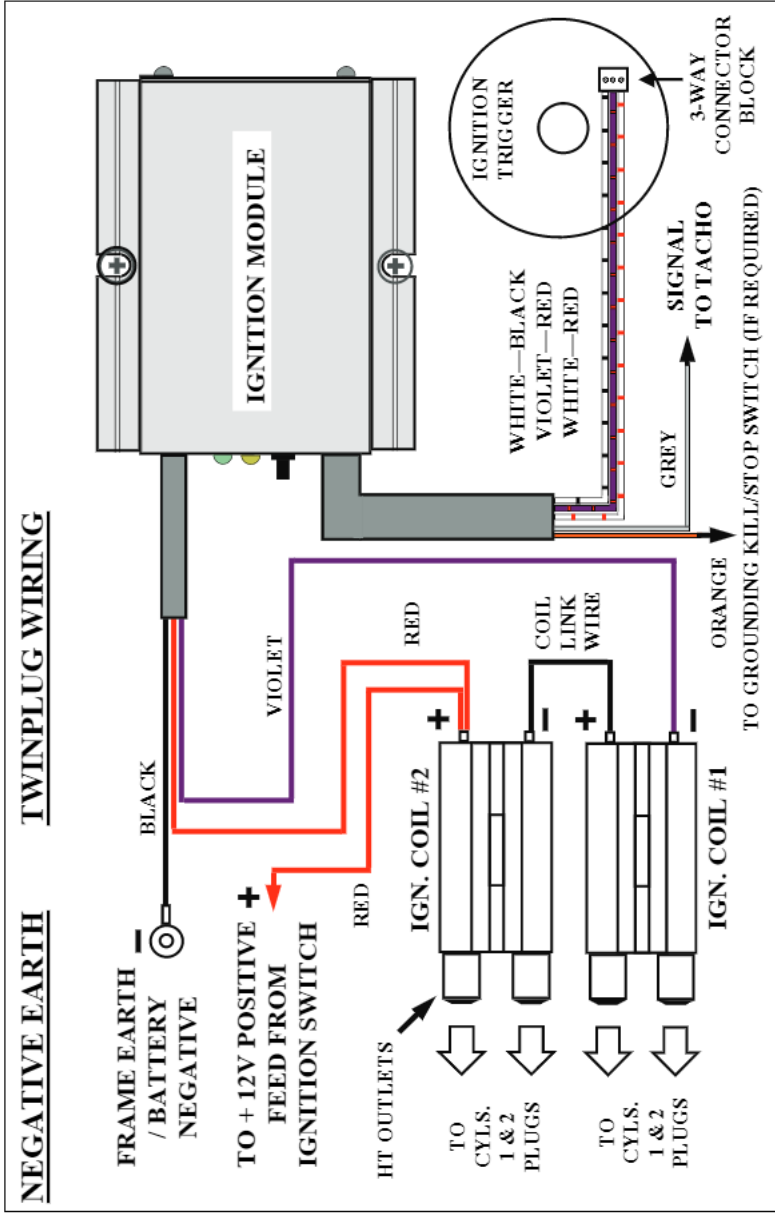

**WARNING: TURN OFF/DISCONNECT THE BATTERY
BEFORE WORKING ON THE SYSTEM
HIGH VOLTAGES CAN KILL**

POSITIVE EARTH

TWINPLUG WIRING

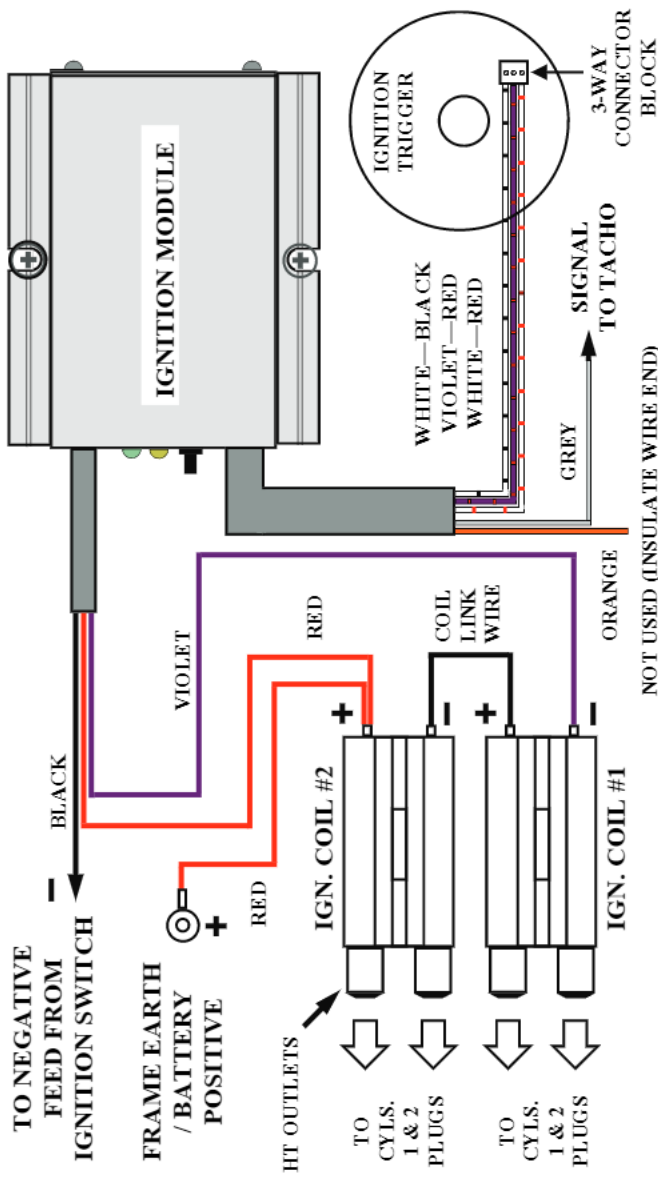

TIMING (see figs. 2-7, pages 12-13)

1. Switch off ignition.
2. If necessary, slightly loosen the ignition trigger pillar fixings so that it can be rotated by hand.

Warning: risk of electric shock, keep hands & body away from coil, ht leads, caps & plugs

3. The following operations may produce a spark from the plugs, therefore it is recommended that violet wire be temporarily removed from the negative terminal of ignition coil #1, place insulating tape over the end of the connector to prevent shorting to ground. Alternatively, the spark plugs be removed and grounded onto the cylinder head (with the plug caps & h.t. leads connected to them). This will prevent any undesired sparks whilst timing.
4. (Reconnect the battery).

Clockwise rotor rotation:

- If not already done, rotate the trigger to the fully counter—clockwise position, as per fig. 2
- Switch the ignition on (the red timing light will normally be OFF)
- Rotate the trigger clockwise until it is positioned as per fig. 3 (the red timing light may turn ON, then OFF)
- Rotate the trigger slowly counter-clockwise until the red timing light turns ON, see fig. 4
- If the red timing light does not turn ON, leave the ignition switched on and repeat the previous steps (figs. 2, 3 & 4) as required, until the trigger is calibrated (light turns ON in fig. 4).

Counter-Clockwise rotor rotation:

- If not already done, rotate the trigger to the fully clockwise position, as per fig. 5
- Switch the ignition on (the red timing light will normally be OFF)
- Rotate the trigger counter—clockwise until it is positioned as per fig. 6 (the red timing light may turn ON, then OFF)
- Rotate the trigger slowly clockwise until the red timing light turns ON, see fig. 7
- If the red timing light does not turn ON, leave the ignition switched on and repeat the previous steps (figs. 5, 6 & 7) as required, until the trigger is calibrated (light turns ON in fig.7).

5. Switch off the ignition.
6. Reconnect the violet wire to the ignition coil, if disconnected in step 3 (above). Refit spark plugs, if removed earlier.
7. If removed earlier, push the plug caps firmly onto the plugs, they should click into place.
8. Refit the fuel tank and/or seat. The engine should now start and after warming up should tick over well, provided everything else is correctly adjusted. The ignition will advance as per the pre-programmed curve (see advance graph, page 15).
9. Strobe timing is not essential, but if desired, proceed as follows:
 - Warm engine for 4-5 mins.
 - Using a white light strobe, time the engine to the full advance mark (standard: 32° BTDC for Triumph, 28° BTDC for BSA, 25° BTDC for Norton)
 - To advance the timing, rotate the trigger the opposite way to the direction of rotor rotation
 - To retard the timing, rotate the trigger in the same direction as the direction of rotor rotation
 - Make very small adjustments; 1° of trigger movement equals 2° of crankshaft movement
 - The trigger has two sets of calibration marks (clockwise and counter-clockwise) on the outer edge to assist with timing adjustment
 - **For safety, switch ignition off between adjustments**

TABLE 1

MOTORCYCLE	CAM. ROTATION	FULL ADVANCE TIMING
TRIUMPH TWIN	CLOCKWISE	32°
BSA TWIN	ANTI-CLOCKWISE	28°
NORTON COMMANDO	ANTI-CLOCKWISE	25°
NORTON ATLAS	CLOCKWISE	25°

STATIC IGNITION TIMING
CLOCKWISE ROTOR ROTATION
(TRIUMPH/NORTON ATLAS)
(WIRING NOT SHOWN FOR CLARITY)

FIG. 2

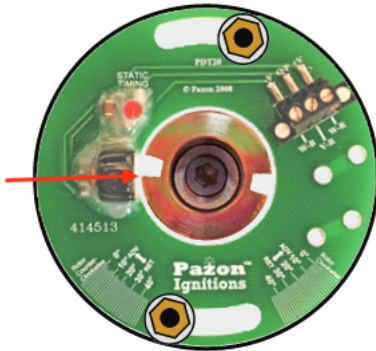

START POSITION
TURN TRIGGER
FULLY COUNTER-CLOCKWISE,
END OF ROTOR SLOT
ALIGNED WITH CENTRE OF
SENSOR, SWITCH IGNITION ON

FIG. 3

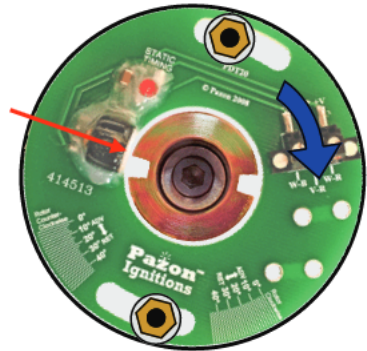

TURN TRIGGER
CLOCKWISE
UNTIL START OF ROTOR SLOT
ALIGNS WITH CENTRE OF
SENSOR, STOP TURNING

FIG. 4

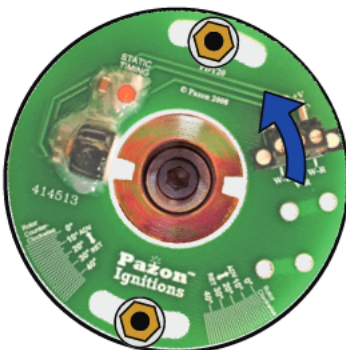

TURN TRIGGER
VERY SLOWLY COUNTER-CLOCKWISE
UNTIL RED TIMING LIGHT
TURNS ON *, STOP TURNING
TIGHTEN TRIGGER PILLAR FIXINGS

* See accompanying text on page 10 for a full description of the static timing light operation

STATIC IGNITION TIMING
COUNTER-CLOCKWISE ROTOR ROTATION
(BSA/NORTON COMMANDO)
(WIRING NOT SHOWN FOR CLARITY)

FIG. 5

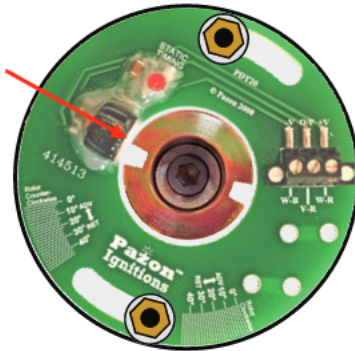

START POSITION
TURN TRIGGER
FULLY CLOCKWISE,
END OF ROTOR SLOT
ALIGNED WITH CENTRE OF
SENSOR, SWITCH IGNITION ON

FIG. 6

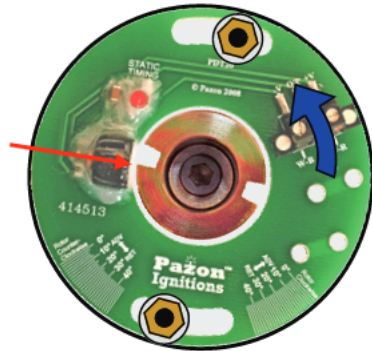

TURN TRIGGER
COUNTER-CLOCKWISE
UNTIL START OF ROTOR SLOT
ALIGNS WITH CENTRE OF
SENSOR, STOP TURNING

FIG. 7

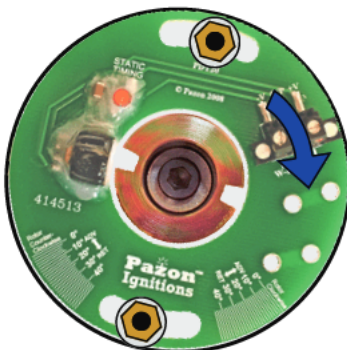

TURN TRIGGER
VERY SLOWLY CLOCKWISE
UNTIL RED TIMING LIGHT
URNS ON *, STOP TURNING
TIGHTEN TRIGGER PILLAR FIXINGS

* See accompanying text on page 10 for a full description of the static timing light operation

REV-LIMITER

USE OF THIS FUNCTION IS AT YOUR OWN RISK, SINCE IT IS POSSIBLE TO SET THE REV-LIMITER TO BEYOND THE DESIGNED UPPER RPM LIMIT FOR YOUR ENGINE.

The **Smart-Fire** ignition module features a function button that enables the user to set/reset the ignition rev-limiter. Unless specified when purchasing the system, the rev-limiter is not preset, allowing your engine to rev to its maximum (unrestricted).

To set the rev-limiter

To accurately set the rev-limiter you will need a rev. Counter/tachometer to monitor the engine rpm. Rev the engine to one-half the desired rev-limit rpm, press & hold the function button for a minimum of 3 seconds. The ignition module will take a snapshot of the engine rpm at the instant the button is pressed, therefore it is not essential to maintain a precise rpm whilst the button is pressed. The yellow indicator led on the module will flash 5 times Release the button. The rev-limiter is now set. When your engine reaches the preset rpm the ignition will turn off the ignition coil, cutting all sparks. Thus, the engine rpm will fall and, once below the rev-limit setting, ignition will resume.

The minimum rev-limiter setting is 3000 rpm (i.e. set with the engine running at 1500 rpm).

To reset the rev-limiter

To reset (disable) the ignition rev-limiter, press & hold the function button for a minimum of 3 seconds, with the engine below 1500 rpm (or stationary). The yellow indicator led on the module will flash 5 times. Release the button. The rev-limiter is now reset.

The rev-limiter setting is retained in the ignition module memory & will be recalled when the ignition is turned on.

Smart-Fire Ignition Timing
TRIUMPH/BSA/NORTON TWIN
TWINPLUG

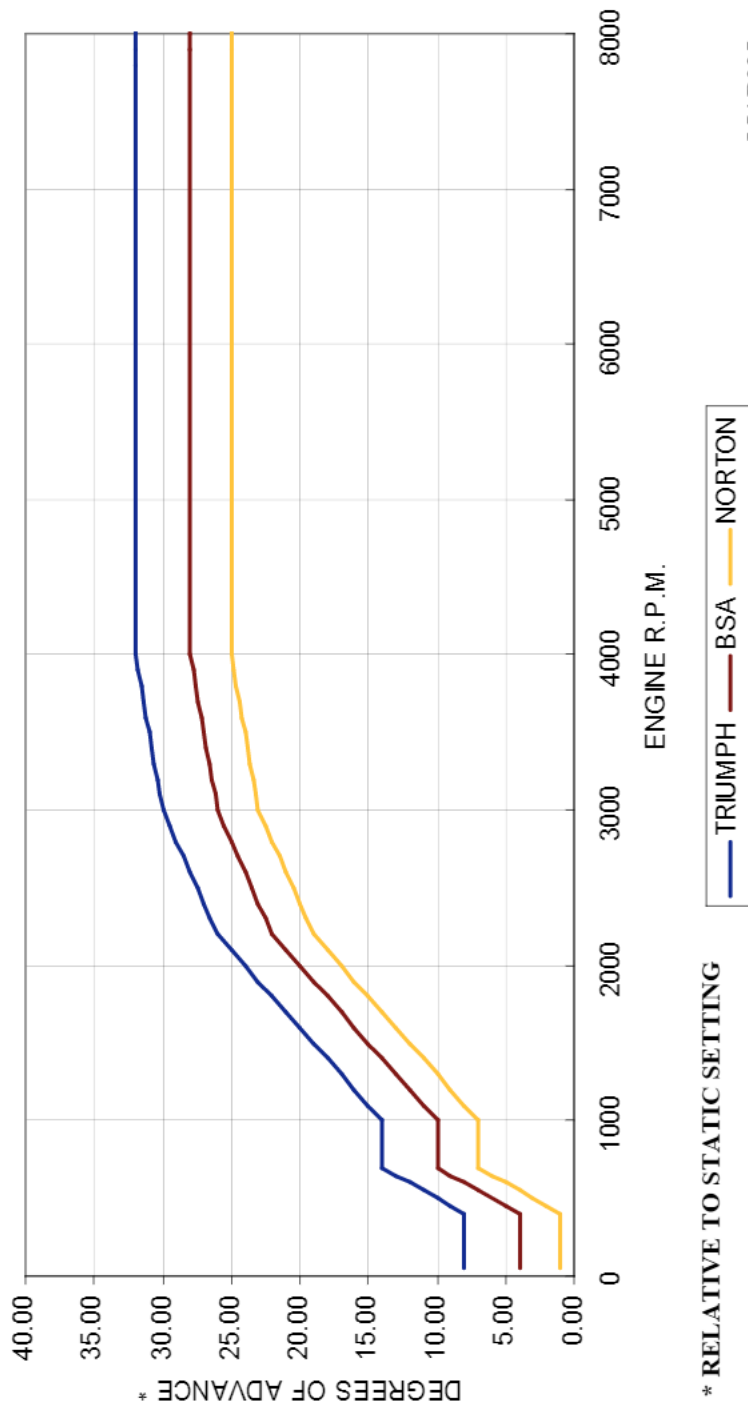

* RELATIVE TO STATIC SETTING

Terms & Conditions and Warranty

- Use of this product indicates your acceptance of this notice.
- The product design, firmware & literature is Copyright © PAZON IGNITIONS LTD. 2005-2009, and is protected under international copyright, trademark & treaty provisions.
- To provide the best ignition systems possible, Pazon Ignitions Ltd. reserves the right to alter and improve the specifications of its products without prior notice.

Ignition Systems

- Pazon Ignitions warrants to the original purchaser that the Pazon Ignition System be free from defects in workmanship & parts under normal use for a period of 7½ years from date of purchase.

Ignition Spares

- Spares are defined as item(s) not purchased as part of a complete ignition system. Pazon Ignitions warrants to the original purchaser that these item(s) be free from defects in workmanship & parts under normal use for a period of one year from date of purchase.
- Ignition coils will only be covered by the warranty if it can be proved that the fault is due to a manufacturing fault within the coil.

Limitation of Liability

- In no event shall Pazon Ignitions' liability related to the product exceed the purchase price actually paid for the product.
- Neither PAZON nor its suppliers shall in any event be liable for any damages whatsoever arising out of or related to the use or inability to use the product, including but not limited to the direct, indirect, special, incidental or consequential damages, or other pecuniary loss.
- This warranty will be void if the product or parts have been altered, damaged, abused or installed incorrectly.
- This warranty will be void if parts supplied by Pazon Ignitions are used with other makes of ignition. Your statutory rights are not affected.

Warranty Claims

- To make a claim under warranty, the product must be returned to Pazon Ignitions or its authorized representative, with a copy of your receipt (or evidence of date and place of purchase), within the warranty period.
- Include a detailed description of the problem and why you believe there is a fault within the ignition system.
- The system must be returned postage paid. Proof of posting is not proof or receipt, therefore we recommend using a recorded mail service.
- Upon receipt we will thoroughly test the returned items and repair or replace any items found to be faulty and covered by the warranty.
- Please allow seven working days from receipt of the returned parts before contacting us, to allow sufficient time for a thorough test and evaluation.
- PLEASE CONTACT PAZON IGNITIONS FOR RETURN INSTRUCTIONS.

✉ **Pazon Ignitions Ltd, 274 Hot Springs Road, RD 2,
Katikati 3178, Bay of Plenty, New Zealand**

☎ **TELEPHONE: +64 (0) 7549 5878** 📠 **FAX: +64 (0) 7549 5879**

EMAIL: ignition@pazon.com WEB: www.pazon.com